



PLIOCATCH

Fixing accessories

X120 - 0560 0003 0018 E



SES-STERLING [®]
www.ses-sterling.com





SES-STERLING®
www.ses-sterling.com

FIXING ACCESSORIES

PLIOCATCH



Cable lock to clip

MU-R200 ...

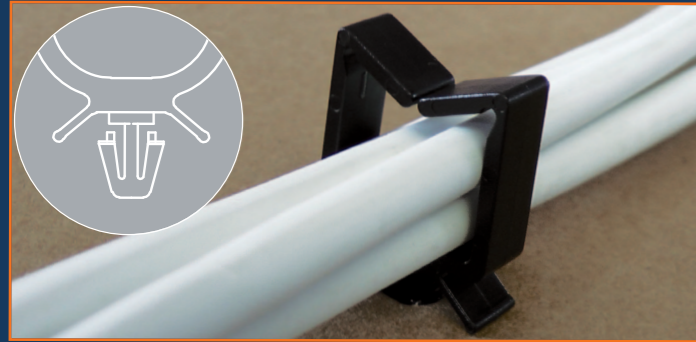

Fastening system for machine or electrical cabinet by clip. The range is composed of 4 models in 2 colours to meet different constraints.

PI-D1100



Clip mounting on switchgear support grid or on DIN rail in enclosures or cabinets.

GA-W



Suitable for horizontal and vertical cable routing at the front or rear of modular elements.

1U-W / 2U-W



Used in the computer field, in 19" rack racks on 1U and 2U strips.

Cable lock to screw

GA-V200 ...

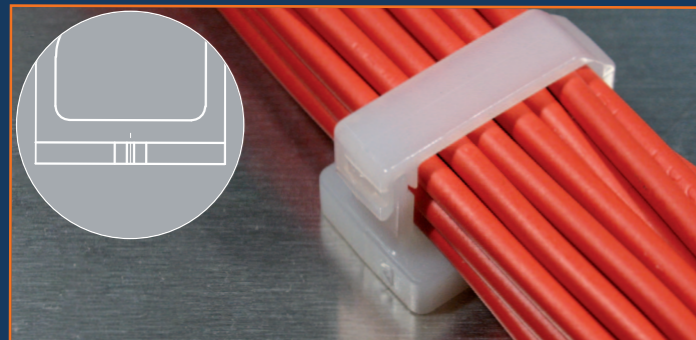

Screw-on cable lock for fixing cables in machines or switch cabinets. The range is composed of 4 models in 2 colours to meet different requirements.

Cable guide DELTA

DELTA L/M



Recommended for the horizontal passage of cables from the back or front of the modular elements mounted on a double profile DIN or a rail DIN OMEGA.

Material:	PA
Colour:	natural - black
Operating temperatures:	-40 to +85°C
Flame resistance:	V2 UL94

PLIOCATCH to clip

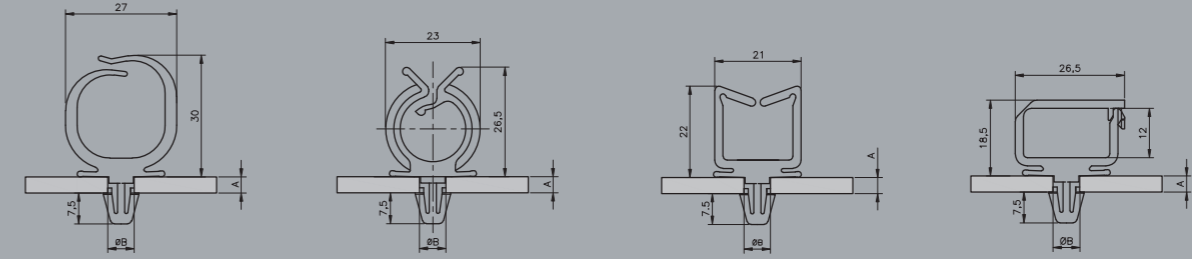

type	article number natural	article number black	A (mm)	Ø B (mm) mm	
TE-R350	0190 0121 018	0190 0121 010	1 ... 3	6 ... 6,4	100
OM-R150	0190 0221 018	0190 0221 010	1 ... 3	6 ... 6,4	100
MU-R200	0190 0321 018	0190 0321 010	1 ... 3	6 ... 6,4	100
GA-R200	0190 0421 018	0190 0421 010	1 ... 3	6 ... 6,4	100

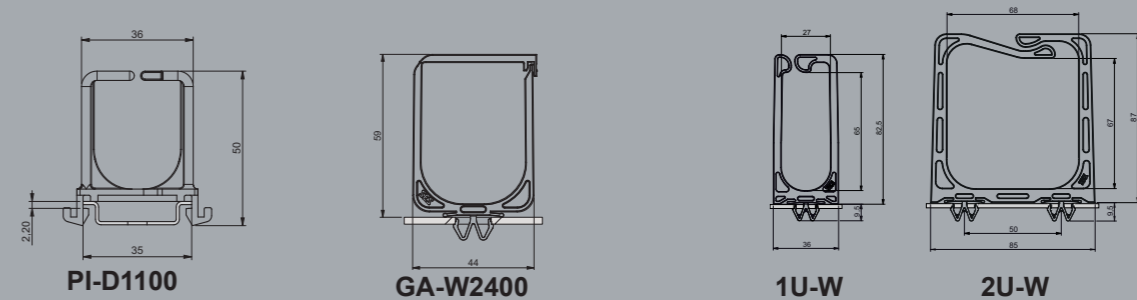

type	article number natural	article number black	
PI-D1100	0190 0531 018	0190 0531 010	100
GA-W 2400	-	0190 0651 010	10
1U-W	-	0190 0703 010	10
2U-W	-	0190 0704 010	10

PLIOCATCH to screw

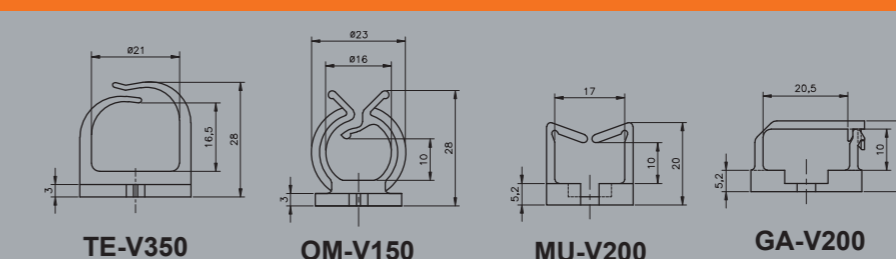

type	article number natural	article number black	
TE-V350	0190 0111 018	0190 0111 010	100
OM-V150	0190 0211 018	0190 0211 010	100
MU-V200	0190 0311 018	0190 0311 010	100
GA-V200	0190 0411 018	0190 0411 010	100

Cable guide

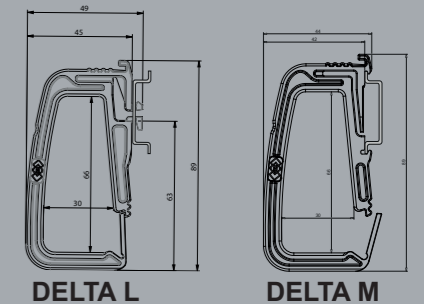

type	article number grey	
DELTA L	0190 0601 013	10
DELTA M	0190 0602 013	10



SES-STERLING [®]
www.ses-sterling.com

All around the cable

WORKING WITH SES-STERLING

We at SES-STERLING take pride in the fact that since our family enterprise was created in 1928, we have managed to grow it into an internationally renowned cable accessories manufacturer that can guarantee fast worldwide delivery to its clients. We're considered as a forerunner in the transformation of raw materials into electrical wiring accessories mainly thanks to the fact that we manage and control the whole production process from A to Z. We can therefore guarantee you top quality and innovative products that are 100% "Made in France".

A strong research culture makes sure the cable protection, marking and fixing products manufactured by SES-STERLING are manufactured to fulfil the needs of all our customers. With more than 26000 product references our catalogue will be able to provide trusted products of any type our clients are seeking offering the best balance between price and quality, without having to compromise on creativity. What you really need is a continuous availability, fast delivery, sufficient stocks and efficient distribution. Thanks to these elements we are able to offer first-class responsiveness, troubleshooting and support for our partners.

Our specialised team of research and development engineers work all year round to be sure that the most effective raw material mixes are used in our products so that the end user will sleep soundly whenever completing a project. All products are constantly adapted for ease of use in the field.

The SES STERLING commercial and technical teams aim to be as close as possible to our all important clients with offices in Switzerland, Belgium, Germany and the United Kingdom. And thanks to our extensive partner network in 50 countries around the world we can offer our quality products to you in the time scale required. Our teams are always ready to listen to your feedback, suggestions and questions. Local contact is the key factor, not only can we respond to your needs, but we aim to fulfil them whenever they arise.

