



# High & Extra-High Voltage Underground Solutions



**SILEC**<sup>®</sup>  
BRAND

## FOREWORD

### POWERFUL PRESENCE PRODUCTS, PERFORMANCE, PEOPLE

General Cable has been a wire and cable innovator for over 170 years, always dedicated to connecting and powering people's lives. With more than 13,000 employees and \$6 billion in revenues, we are one of the largest wire and cable manufacturers in the world.

Our company serves customers through a global network of 38 manufacturing facilities in our core operating regions and has worldwide sales representation and distribution. We are dedicated to the production of high-quality aluminum, copper and fiber optic wire and cable and systems solutions for the energy, construction, industrial, specialty and communications sectors. With a vast portfolio of products to meet thousands of diverse application requirements, we continue to invest in research and development in order to maintain and extend our technology leadership by developing new materials, designing new products, and creating new solutions to meet tomorrow's market challenges.

In addition to our strong brand recognition and strengths in technology and manufacturing, General Cable is also competitive in such areas as distribution and logistics, sales and customer service. This combination enables us to better serve our customers as they expand into new geographic markets.

**General Cable offers our customers all the strengths and value of a large company, but our people give us the agility and responsiveness of a small one. We service you globally or locally.**

Visit our Website at [www.generalcable.com](http://www.generalcable.com)



# INDEX

<b>INTRODUCTION</b>	<b>04</b>
<b>USER'S GUIDE</b>	<b>06</b>
Technical datas in tables	06
Current ratings – correction factors	07
Earth bonding schemes	08
Electrical features of cables	10
Installation	12
Packaging and transportation	13
<b>CABLES</b>	<b>14</b>
Aluminium Sheath	15
Copper Wires with Lead Sheath	24
Copper Wires with Aluminium Laminated Foil	33
<b>ACCESSORIES</b>	<b>42</b>
<b>SERVICE</b>	<b>54</b>
Turnkey service	54
Customer service	56
Monitoring & Diagnosis	57
Stand-by links	60

# INTRODUCTION

## A WORLDWIDE HIGH VOLTAGE LEADER

General Cable's SILEC® HV/EHV underground transmission cables and accessories are reliable and environmentally sound to meet the needs of current and future utility transmission systems. They exceed the requirements of our customers' technical specifications while meeting international standards like IEC 60840, IEC 60287, IEC 62067, ICEAS-108-720 and AEIC CS9.

Significant in-house testing includes:

- >> Qualification testing for cables up to 500 kV
- >> Testing capabilities for voltage up to 700 kV
- >> Partial Discharge (PD) testing to < 1 pC

## RELY ON OUR EXPERIENCE ... EXPERIENCE OUR CAPABILITIES

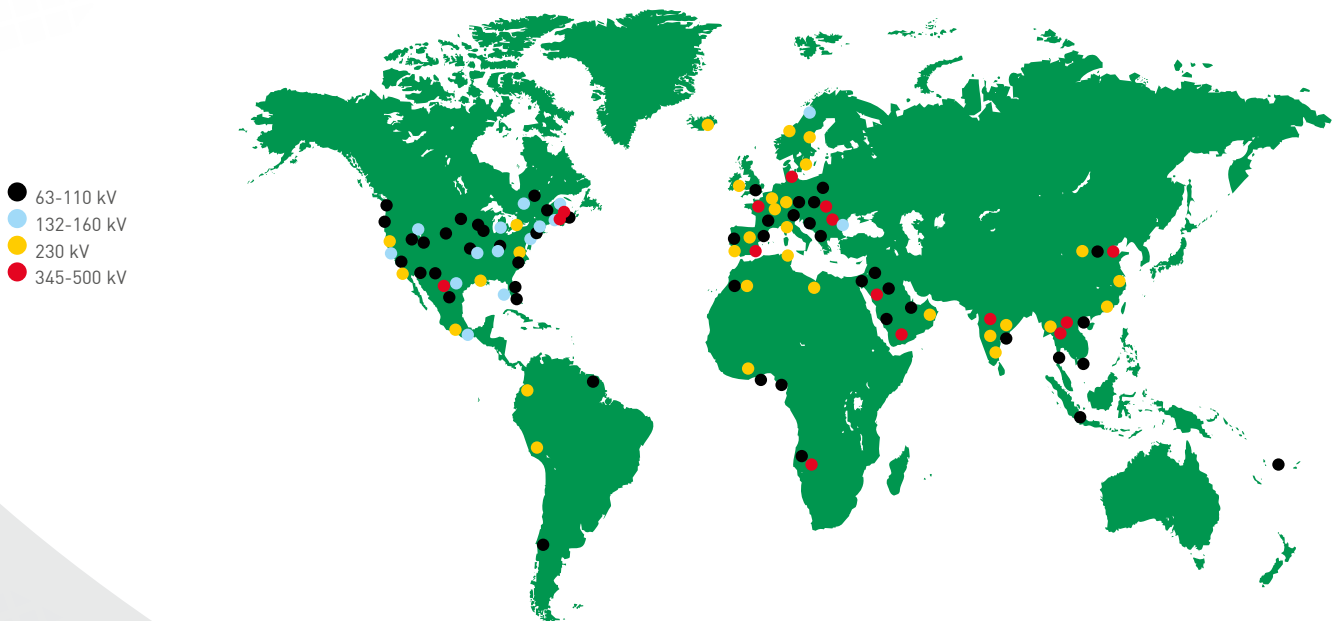



## 40 YEARS OF WORLDWIDE HIGH- & EXTRA-HIGH-VOLTAGE FIRSTS

The SILEC® brand name has been synonymous with solid-dielectric extruded cable solutions for nearly fifty years. General Cable offers a fully integrated approach to providing a comprehensive range of quality SILEC® high- and extra-high-voltage cable systems. They are designed, engineered and manufactured to ensure maximum service life and best-in-class performance while maintaining cost effectiveness.

### VOLTAGE RANGE

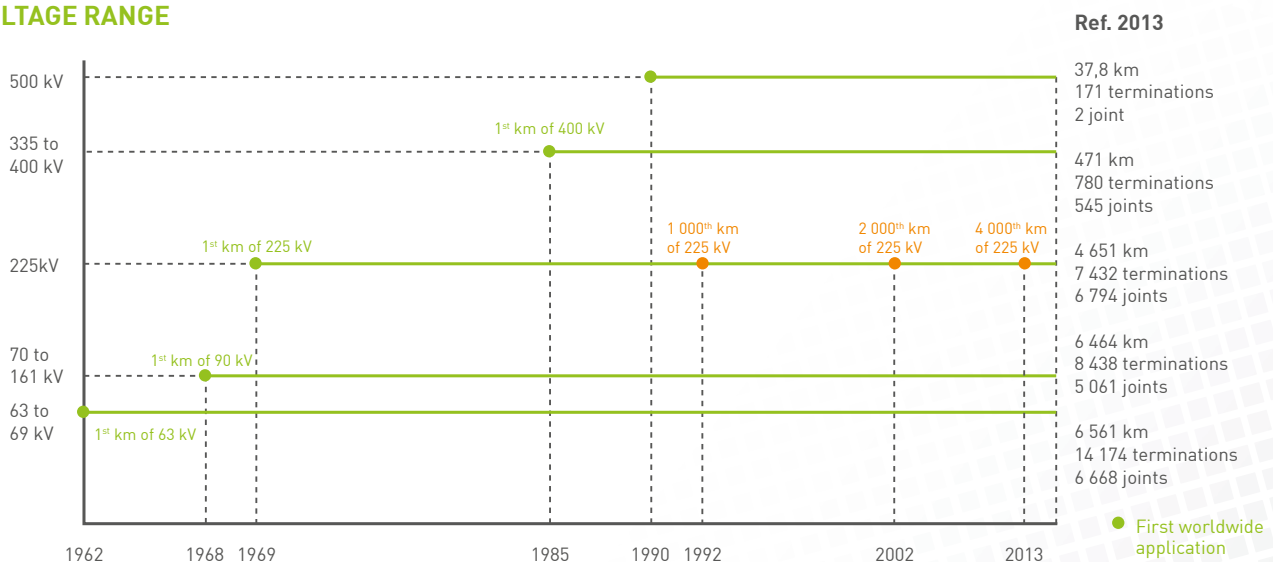

Voltage level	63-161 kV	220-230 kV	330-500 kV
Cable (km)	9 947	6 561	508,8
Terminations	22 612	7 432	951
Joints	11 729	6 794	547

Ref. 2010

# USER'S GUIDE

## TECHNICAL DATA IN TABLES

Though General Cable can provide a wide range of design regarding metal screen, moisture barrier, we will focus on 3 types of designs in the following chapters:

- >> Aluminium sheath
- >> Copper wires and lead sheath
- >> Copper wires and aluminium laminate foil

In the tables, we gathered the data relating to each design for each of value of  $U_m$  and for both copper and aluminium conductor.

Among all these data, you will find the current carrying capacity for different types of configurations. The related calculations were performed according to the following conditions:

### Load factor = 1

#### Direct buried:

- >> Trefoil with no space between cables
- >> Laying depth: 1,5 m » Soil temperature: 20°C
- >> Thermal resistivity of the soil: 1 K.m/W
- >> No soil drying
- >> No thermal proximity

#### Pulled in ducts:

- >> Trefoil with no space between ducts
- >> Depth at the centre of the duct bank: 1,5 m
- >> Soil temperature: 20°C
- >> Thermal resistivity of the soil: 1 K.m/W
- >> Thermal resistivity of the concrete: 1 K.m/W
- >> HDPE ducts
- >> No soil drying
- >> No thermal proximity

#### Installation in free air

- >> Trefoil with no space between cables or flat with axis-to-axis space between two conductors equal to 2 times overall diameter of cable
- >> Cable exposed to solar radiation (1 000 W/m<sup>2</sup>)
- >> Air temperature: 30°C
- >> No thermal proximity

Please note that the following data enable only a first assessment of the needed cross-section in relation to the power to be transmitted. This cannot in any manner replace the calculations performed by General Cable's engineering department.



# CURRENT RATINGS CORRECTION FACTORS

The configurations in service are often different from the ones detailed in the former paragraph. In such a situation, you can apply those correction factors to the currents of the tables of the following chapters as explained below.

The tables in this section cover the installation conditions most commonly encountered. The following correction factors have been provided in order to calculate various laying conditions based on these five parameters:

- >> Temperature of the ground
- >> Temperature of the air
- >> Laying depth
- >> Thermal resistivity of the ground
- >> Proximity of circuits

The relating factors are given in the following tables:

## GROUND TEMPERATURE

Ground Temperature (°C)	10	15	20	25	30	35	40	45
Correction Factor	1,07	1,04	1	0,96	0,93	0,88	0,84	0,8

## AIR TEMPERATURE

Air Temperature (°C)	10	20	30	40	50	60
Correction Factor	1,18	1,1	1	0,9	0,79	0,67

## LAYING DEPTH

Laying Depth (m)	1,0	1,2	1,5	2,0	2,5	3,0	4,0	5,0
Correction Factor	1,05	1,03	1	0,97	0,95	0,92	0,89	0,87

## THERMAL RESISTIVITY OF THE GROUND

Thermal Resistivity (Km/W)	0,8	1,0	1,2	1,5	2,0	2,5
Correction Factor	1,09	1	0,93	0,85	0,74	0,67

## PROXIMITY OF CIRCUIT

Axis-to-axis spacing between 2 Cable Systems (*) (mm)	Number of Cable Systems (*)					
	1	2	3	4	5	6
200	1	0,78	0,67	0,61	0,60	0,57
400	1	0,83	0,73	0,68	0,67	0,65
600	1	0,86	0,78	0,75	0,72	0,70
800	1	0,89	0,80	0,78	0,75	0,74

[\*] A cable system is a set of 3 phase conductors

# EARTH BONDING SCHEMES

During the engineering phase of a project, designing the bonding scheme is aiming at finding the optimized balance between:

- >> Minimizing the ampacity of the induced currents in the metal screens of cables
- >> Maintaining the induced voltage at screen ends which are not solidly bonded to earth under a certain value

Most common bonding methods are the following ones:

- >> Bonding at several points of the circuit called below “solid bonding”
- >> Bonding at one point of the circuit either at one termination, either at one joint
- >> Cross-bonding with or without link boxes

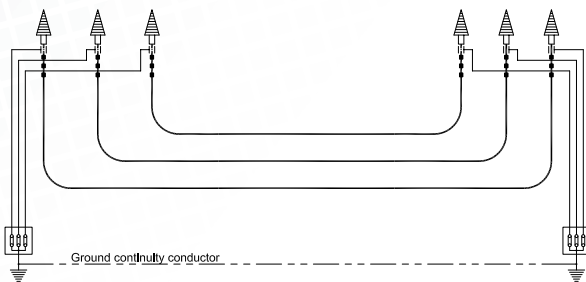

## Solid bonding:

This method is less demanding regarding engineering and less complex components. The main drawback is the increasing of losses due to induced currents in the metal sheaths reducing the cable transmission capacity.

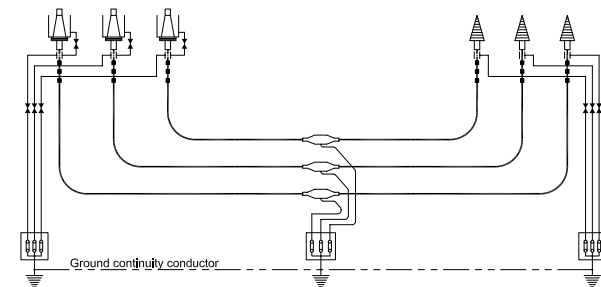
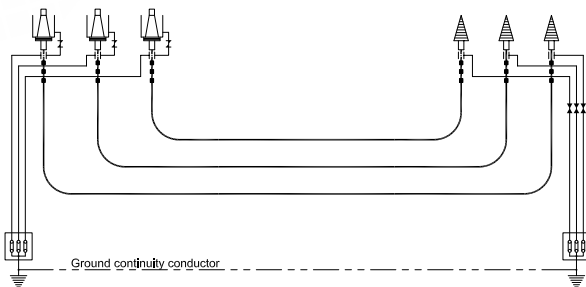

## Bonding at one termination or at one joint:

In this configuration, we avoid circulating current in the metal sheaths. On the other hand, an induced voltage at metal sheaths ends will have to be managed through the insertion of surge voltage limiters. Usually this bonding scheme is limited to relatively short circuit due to the accepted metal sheath voltage.

Depending on the project constraints and on grids parameters, you either use link boxes to insert surge voltage limiters at each sectionalisation of the metal sheaths, either cross-connect without link boxes depending on the induced voltages we are likely to experiment in service.

The engineering phase of a project will make possible to design the most appropriate bonding scheme and each project being very specific, this has to be checked case by case.

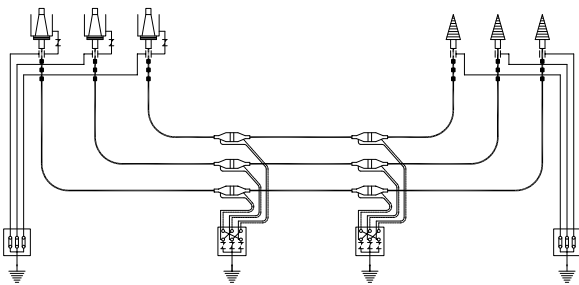





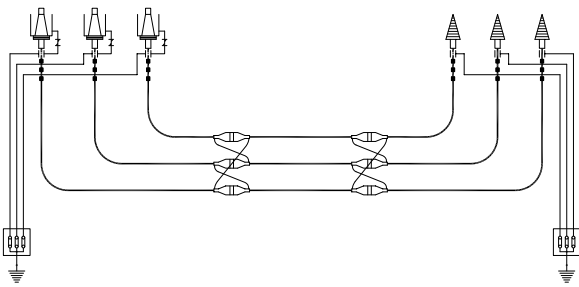



**Cross-bonding with link boxes:**

Cross-bonding is based on a solid bonding at each termination, sectionalisation and cross connections of metal sheaths ends in such a way that the resulting circulating currents are reduced to zero. This type of bonding implies a number of spans multiple of 3 and, as much as possible with a constant unit length between each span of a primary section (a set of 3 consecutive sections).



**Cross-bonding without link boxes:**

The use of cross-bonding without link boxes makes the installation easier and less civil work demanding resulting in an optimization of the time-frame of the implementation of a project. Nevertheless, in such a configuration, you have to make sure the cable system will withstand the dielectric stress during usual service conditions or during a short-circuit, switching operations or if a lightning impulse propagates along the cable route.

 Outdoor termination	 Metal-enclosed termination	 Splice with grounding and three-phase grounding box	 Shield interruption splice and cross-bonding box including SVL
 Three-phase grounding box	 Surge Voltage Limiter	 Clamp	 Local Ground

# ELECTRICAL FEATURES OF CABLES

## APPARENT TRANSMISSION CHARACTERISTICS

**Capacitance:**

$$C = \frac{\epsilon}{18 \text{ Ln} \left( \frac{r_2}{r_1} \right)}, \mu\text{F/km}$$

where:

- >>  $\epsilon$  = relative permittivity of the insulation
- >>  $r_1$  = radius at the surface of the conductor screen [mm]
- >>  $r_2$  = radius at the surface of the insulation [mm]

**Dielectric Losses:**

$$W = U_0^2 C \omega \text{ tg} \delta \cdot 10^{-6}, \text{W/km}$$

where:

- >>  $U_0$  = is the applied voltage between the conductor and the metal screen (kV)
- >>  $C$  = capacitance of the cable ( $\mu\text{F/km}$ )
- >>  $\omega = 2 \pi f$  where  $f$  is the frequency (Hz)
- >>  $\text{tg} \delta$  = is the loss angle

**Inductance:**

$$L = \left[ 0.05 + 0.2 \text{ Ln} \left( \frac{2 a_m}{d} \right) \right] 10^{-3}, \text{H/km}$$

where:

- >>  $a_m$  =  $a$  in trefoil formation where  $a$  is the axis-to-axis spacing between conductors (mm)  
 $a_m = 1.26 a$  in flat formation where  $a$  is the axis to axis spacing between conductors (mm)
- >>  $d$  = diameter of the conductor (mm)

## Electric Stress

Electric stress over the surface of the conductor screen:

$$E_1 = \frac{u_0}{r_1 \ln\left(\frac{r_2}{r_1}\right)}, \text{ kV/mm}$$

Electric stress over the surface of the insulation:

$$E_2 = \frac{u_0}{r_2 \ln\left(\frac{r_2}{r_1}\right)}, \text{ kV/mm}$$

where:

- >>  $U_0$  = is the applied voltage between the conductor and the metal screen (kV)
- >>  $r_1$  = radius at the surface of the conductor screen (mm)
- >>  $r_2$  = radius at the surface of the insulation (mm)



Shielded room for testing of EHV cables (France)

# INSTALLATION

The cables have not only to withstand thermal, thermo-mechanical and electrical stresses in service but also mechanical stresses during installation operations. In this respect, the following features have to be taken into consideration.

## CABLE HANDLING DURING INSTALLATION

### Minimum Bending Radius

- >> Minimum bending radius when pulling on rolls: 30 D
- >> Minimum bending radius when pulling in pipes: 35 D
- >> Minimum bending radius after installation: 20 D

D = the overall diameter of the cable

### Maximum Pulling Force

A traction force is applied at one end of the cable when pulling a cable. Most of the stress is supported by the conductor, so a pulling head has to be secured to the conductor.

Use of a pulling sleeve is restricted where the pulling force is limited to a maximum of 500 daN.

Maximum tensile load on the conductor:

- >> 5 daN/mm<sup>2</sup> for aluminium conductors
- >> 6 daN/mm<sup>2</sup> for copper conductors

### Maximum Sidewall Pressure

Type of design	In ducts (daN/m)	On rollers (daN)
Wires + aluminium foil	1 000	100
Aluminium foil alone	2 500	100
Wires + lead sheath	1 000	100
Lead sheath alone	2 500	100

The above data should be used when performing a preliminary assessment. General Cable advises its customers to contact us for the engineering of each cable link, as each project is a specific case of study.

### Electro-Dynamic Forces

When a short-circuit current is circulating in 2 conductors, it creates a force between the conductors which can be calculated with the following formula:

$$F = \frac{0,2}{a} I_{cc}^2 \text{ peak} , \text{ N/m}$$

where:

- >>  $I_{cc} \text{ peak} = 2.5 I_{cc} \text{ (kA)}$
- >>  $I_{cc} = \text{short-circuit current RMS (kA)}$
- >>  $a = \text{axis-to-axis spacing between conductors (m)}$

# PACKAGING & TRANSPORTATION

During the engineering phase of a project one vital part is the optimization of the unit lengths of cables which have to be the best compromise taking into consideration the constraints resulting from transportation to site, transportation on site if needed, storage on site and pulling operation along the whole cable route.

Some years ago, the unit lengths were not exceeding a few hundred meters and about 35 tons depending on the dimension and weight of the cable. Now it is becoming more and more common to deliver unit lengths exceeding significantly 1 000 meters and 50 tons, thus optimizing the global costs of a project and the time frame of its implementation from engineering optimization to commissioning.





## 1. CONDUCTOR

Manufacturing up to 2 500 mm<sup>2</sup> conductor.

- >> Copper or enameled copper or aluminium stranded wires, watertight or non-watertight
- >> Compact round
- >> Segmental for Milliken conductor [recommended at 1 000 mm<sup>2</sup> and above] to achieve high ampacities

## 2. INSULATION

Triple-head extrusion processed on the only-one-of-its-kind 100 m deep vertical line shaft to achieve optimum insulation concentricity. The use of super-clean Cross-Linked Polyethylene [XLPE] provides long-term high dielectric performance.

- 2.1 Inner semi-conductive layer
- 2.2 Insulation
- 2.3 Outer semi-conductive layer

## 3. LONGITUDINAL WATER BARRIER

Swelling semi-conductive tape [under and over wire screen or optional optical fibre tubes].

## 4. METAL SCREEN/RADIAL MOISTURE BARRIER

Sheathing options for short circuit requirements and radial moisture barrier.

- >> Concentric wires: copper or aluminium
- >> Foil laminate: aluminium
- >> Welded
- >> Lead sheath

## 5. JACKET

Jacketing options for mechanical, chemical protection.

- >> High Density Polyethylene [HDPE] or Low Density Polyethylene [LDPE]
- >> Fire-retardant low-smoke oversheath
- >> Polyvinyl Chloride [PVC]
- >> Conductive coating on demand

## 6. ADDITIONAL COMPONENTS

- >> Proprietary  $\mu$ Cable<sup>®</sup>, fibres [single- or multimode] within a Polyethylene (PE) tube for flexibility and improved stripability, is integrated into the high- or extra highvoltage cable for temperature monitoring via DTS system
- >> General Cable can also provide standard stainless steel tube with single or multimode optical fibres

# ALUMINIUM SHEATH

(Specified and tested according to IEC 60840 and IEC 62067)

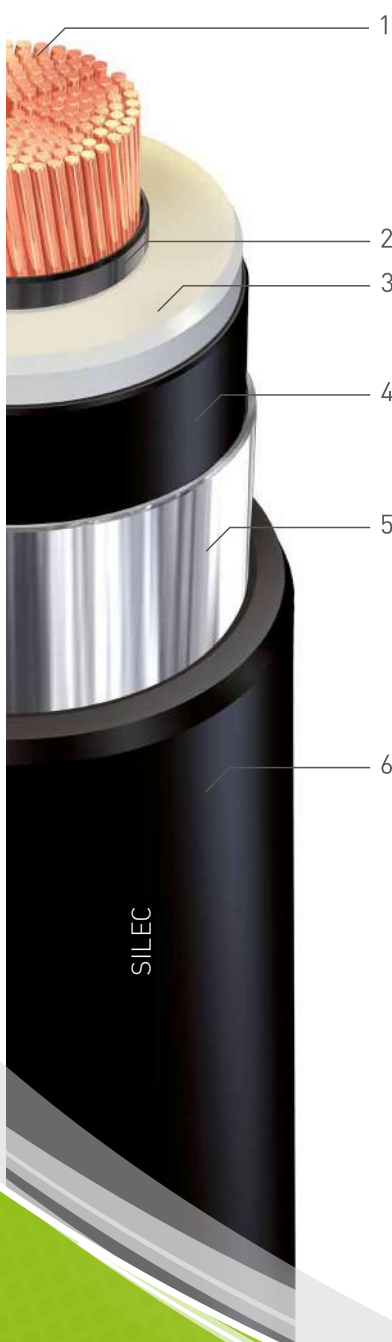

**Range of voltage  $U_m$ : 72,5 kV to 550 kV**

**Range of cross-section: 240 mm<sup>2</sup> to 2 500 mm<sup>2</sup> copper or aluminium**

## CONSTRUCTION:

### 1. CONDUCTOR

Annealed copper - Class 2

Aluminium - Class 2

Concentric conductor  $\leq 1\,000\text{ mm}^2$

Milliken or optimized Milliken conductor  $\geq 1\,200\text{ mm}^2$

### 2. INNER SEMI-CONDUCTOR LAYER

Extruded semi-conducting compound

### 3. INSULATION

Cross-Linked Polyethylene (XLPE)

### 4. OUTER SEMI-CONDUCTOR LAYER

Extruded semi-conducting compound

### 5. SCREEN

Aluminium foil

### 6. SHEATH

HDPE or halogen-free fire-retardant oversheath

Optional: conductive coating



**Um = 72,5 kV**

Sections mm <sup>2</sup>	Overall diametre mm	Weight (Kg/m)	DC conductor resistance at 20 °C Ω/km	AC apparent conductor resistance at 90 °C	Capacitance µF/km	CONTINUOUS CURRENT RATING, A Earthing at one point				CONTINUOUS CURRENT RATING, A Earthing in several points			
						Direct buried	Pulled in ducts	In air, trefoil Exposed to solar radiation (*)	In air, flat Exposed to solar radiation (*)	Direct buried	Pulled in ducts	In air, trefoil Exposed to solar radiation (*)	In air, flat Exposed to solar radiation (*)
240	55,0	3,8	0,0754	0,0974	0,23	521	542	567	582	486	429	538	544
300	58,0	5,0	0,0601	0,0783	0,25	587	614	649	666	541	467	610	614
400	60,0	5,9	0,0470	0,0622	0,27	667	702	755	773	604	508	699	699
500	65,0	7,2	0,0366	0,0496	0,31	751	795	862	880	667	552	788	782
630	68,0	8,6	0,0283	0,0399	0,34	841	901	982	1 000	735	595	884	872
800	72,0	10,4	0,0221	0,0329	0,37	931	1 009	1 109	1 125	797	637	982	961
1 000	78,5	12,9	0,0176	0,0237	0,42	1 100	1 183	1 351	1 359	872	697	1 122	1 072
1 200	83,0	14,7	0,0151	0,0207	0,45	1 173	1 271	1 462	1 462	906	726	1 188	1 127
1 600	90,0	18,9	0,0113	0,0163	0,47	1 304	1 437	1 665	1 644	953	767	1 288	1 209
2 000	96,0	22,8	0,0090	0,0137	0,52	1 400	1 564	1 831	1 788	989	805	1 371	1 277



**Um = 72,5 kV**

Sections mm <sup>2</sup>	Overall diametre mm	Weight (Kg/m)	DC conductor resistance at 20 °C Ω/km	AC apparent conductor resistance at 90 °C	Capacitance µF/km	CONTINUOUS CURRENT RATING, A Earthing at one point				CONTINUOUS CURRENT RATING, A Earthing in several points			
						Direct buried	Pulled in ducts	In air, trefoil Exposed to solar radiation (*)	In air, flat Exposed to solar radiation (*)	Direct buried	Pulled in ducts	In air, trefoil Exposed to solar radiation (*)	In air, flat Exposed to solar radiation (*)
240	54,0	2,3	0,1250	0,1609	0,23	408	422	444	457	391	362	430	438
300	57,0	3,1	0,1000	0,1290	0,25	461	477	509	525	437	398	489	498
400	59,0	3,5	0,0778	0,1009	0,27	529	550	597	615	496	441	569	576
500	64,0	4,2	0,0605	0,0791	0,31	599	625	685	704	554	483	645	650
630	67,0	4,6	0,0469	0,0622	0,34	683	715	796	816	622	531	741	742
800	71,0	5,3	0,0367	0,0497	0,37	769	810	913	934	688	577	838	833
1 000	77,5	6,5	0,0291	0,0408	0,41	856	908	1 041	1 102	752	624	940	956
1 200	82,0	7,0	0,0247	0,0357	0,44	916	978	1 128	1 146	791	654	1 006	988
1 600	91,0	8,8	0,0186	0,0241	0,47	1 103	1 172	1 396	1 400	865	715	1 149	1 099
2 000	95,0	10,2	0,0149	0,0195	0,53	1 220	1 305	1 588	1 576	920	765	1 261	1 194

[\*] Without exposure to direct solar radiation, we consider the ampacity is about 20% higher



Um = 123 kV

Sections mm <sup>2</sup>	Overall diameter mm	Weight (Kg/m)	DC conductor resistance at 20 °C Ω/km	AC apparent conductor resistance at 90 °C	Capacitance µF/km	CONTINUOUS CURRENT RATING, A Earthing at one point				CONTINUOUS CURRENT RATING, A Earthing in several points			
						Direct buried	Pulled in ducts	In air, trefoil Exposed to solar radiation (*)	In air, flat Exposed to solar radiation (*)	Direct buried	Pulled in ducts	In air, trefoil Exposed to solar radiation (*)	In air, flat Exposed to solar radiation (*)
240	68,0	5,5	0,0754	0,0973	0,15	519	535	560	575	488	440	538	545
300	69,5	6,1	0,0601	0,0781	0,17	585	605	640	657	544	481	610	616
400	71,0	7,0	0,0470	0,0619	0,18	662	689	737	755	605	523	693	695
500	74,0	8,0	0,0366	0,0493	0,22	750	786	853	872	673	570	791	788
630	77,0	9,6	0,0283	0,0395	0,24	840	889	972	989	736	611	884	874
800	82,0	11,5	0,0221	0,0324	0,25	932	995	1 099	1 115	802	660	986	968
1 000	89,0	14,2	0,0176	0,0236	0,28	1 091	1 162	1 327	1 332	862	714	1 112	1 067
1 200	93,5	16,1	0,0151	0,0206	0,30	1 162	1 246	1 435	1 431	892	741	1 174	1 120
1 600	100,5	20,4	0,0113	0,0162	0,32	1 294	1 468	1 636	1 614	942	753	1 280	1 209
2 000	106,5	24,5	0,0090	0,0136	0,35	1 389	1 607	1 803	1 758	977	786	1 365	1 280



Um = 123 kV

Sections mm <sup>2</sup>	Overall diameter mm	Weight (Kg/m)	DC conductor resistance at 20 °C Ω/km	AC apparent conductor resistance at 90 °C	Capacitance µF/km	CONTINUOUS CURRENT RATING, A Earthing at one point				CONTINUOUS CURRENT RATING, A Earthing in several points			
						Direct buried	Pulled in ducts	In air, trefoil Exposed to solar radiation (*)	In air, flat Exposed to solar radiation (*)	Direct buried	Pulled in ducts	In air, trefoil Exposed to solar radiation (*)	In air, flat Exposed to solar radiation (*)
240	67	4	0,1250	0,1609	0,15	406	416	438	451	391	367	427	436
300	68,5	4,2	0,1000	0,1290	0,17	458	470	501	516	438	405	486	495
400	70	4,6	0,0778	0,1008	0,19	524	539	582	599	494	448	559	567
500	73	4,9	0,0605	0,0789	0,22	597	617	676	695	556	494	643	649
630	76	5,6	0,0469	0,0617	0,24	680	706	785	804	621	541	736	738
800	81	6,4	0,0367	0,0495	0,25	767	799	900	920	689	592	834	832
1 000	88	7,8	0,0291	0,0405	0,28	853	895	1 024	1 042	747	636	931	921
1 200	92,5	8,4	0,0247	0,0354	0,30	912	962	1 110	1 125	785	665	995	979
1 600	99,5	10,3	0,0186	0,0241	0,32	1 093	1 192	1 366	1 369	854	705	1 136	1 093
2 000	105,5	11,9	0,0149	0,0195	0,35	1 208	1 333	1 555	1 541	907	748	1 248	1 190

[\*] Without exposure to direct solar radiation, we consider the ampacity is about 20% higher



**Um = 145 kV**

Sections mm <sup>2</sup>	Overall diameter mm	Weight (Kg/m)	DC conductor resistance at 20 °C Ω/km	AC apparent conductor resistance at 90 °C	Capacitance μF/km	CONTINUOUS CURRENT RATING, A Earthing at one point				CONTINUOUS CURRENT RATING, A Earthing in several points			
						Direct buried	Pulled in ducts	In air, trefoil Exposed to solar radiation (*)	In air, flat Exposed to solar radiation (*)	Direct buried	Pulled in ducts	In air, trefoil Exposed to solar radiation (*)	In air, flat Exposed to solar radiation (*)
240	64,0	4,4	0,0754	0,0973	0,17	519	537	563	578	482	434	536	542
300	67,0	5,2	0,0601	0,0782	0,18	583	606	641	657	534	473	604	608
400	70,0	6,1	0,0470	0,0619	0,19	659	689	737	753	591	513	683	684
500	75,5	8,3	0,0366	0,0493	0,22	744	783	849	864	657	561	777	774
630	78,5	9,8	0,0283	0,0395	0,23	836	888	973	987	721	604	874	864
800	83,5	11,8	0,0221	0,0324	0,25	924	990	1 092	1 103	781	648	967	949
1 000	90,0	14,4	0,0176	0,0236	0,27	1 083	1 157	1 319	1 320	845	706	1 095	1 053
1 200	96,0	16,5	0,0151	0,0206	0,29	1 153	1 236	1 423	1 416	874	736	1 155	1 105
1 600	101,3	20,5	0,0113	0,0161	0,31	1 290	1 463	1 631	1 537	940	755	1 279	1 149
2 000	108,5	24,8	0,0090	0,0136	0,33	1 386	1 599	1 979	1 752	975	790	1 365	1 282



**Um = 145 kV**

Sections mm <sup>2</sup>	Overall diameter mm	Weight (Kg/m)	DC conductor resistance at 20 °C Ω/km	AC apparent conductor resistance at 90 °C	Capacitance μF/km	CONTINUOUS CURRENT RATING, A Earthing at one point				CONTINUOUS CURRENT RATING, A Earthing in several points			
						Direct buried	Pulled in ducts	In air, trefoil Exposed to solar radiation (*)	In air, flat Exposed to solar radiation (*)	Direct buried	Pulled in ducts	In air, trefoil Exposed to solar radiation (*)	In air, flat Exposed to solar radiation (*)
240	63	2,9	0,1250	0,1609	0,17	406	418	441	454	388	364	427	436
300	66	3,3	0,1000	0,1290	0,18	458	472	503	517	433	400	484	492
400	69	3,7	0,0778	0,1008	0,20	522	540	583	599	486	442	555	562
500	74,5	5,2	0,0605	0,0789	0,21	595	616	674	691	547	488	636	641
630	77,5	5,8	0,0469	0,0617	0,23	677	705	783	800	611	534	728	729
800	82,5	6,7	0,0367	0,0495	0,25	762	796	895	913	675	583	822	819
1 000	89	7,9	0,0291	0,0404	0,27	849	892	1 020	1 036	738	630	922	912
1 200	95	8,8	0,0247	0,0353	0,28	908	957	1 103	1 116	773	662	983	968
1 600	100,3	10,4	0,0186	0,0241	0,31	1 090	1 189	1 362	1 305	853	706	1 134	1 040
2 000	107,5	12,2	0,0149	0,0195	0,33	1 205	1 322	1 548	1 535	906	751	1 247	1 190

[\*] Without exposure to direct solar radiation, we consider the ampacity is about 20% higher



Um = 170 kV

Sections mm <sup>2</sup>	Overall diameter mm	Weight (Kg/m)	DC conductor resistance at 20 °C Ω/km	AC apparent conductor resistance at 90 °C	Capacitance µF/km	CONTINUOUS CURRENT RATING, A Earthing at one point				CONTINUOUS CURRENT RATING, A Earthing in several points			
						Direct buried	Pulled in ducts	In air, trefoil Exposed to solar radiation (*)	In air, flat Exposed to solar radiation (*)	Direct buried	Pulled in ducts	In air, trefoil Exposed to solar radiation (*)	In air, flat Exposed to solar radiation (*)
300	69,5	5,4	0,0601	0,0781	0,17	581	604	639	654	530	474	600	605
400	73,5	6,4	0,0470	0,0619	0,18	656	686	733	747	585	517	678	680
500	79,5	7,9	0,0366	0,0492	0,20	739	779	843	855	644	563	767	765
630	82,0	9,4	0,0283	0,0393	0,21	827	880	960	969	703	603	856	848
800	87,5	12,4	0,0221	0,0323	0,23	914	982	1 082	1 086	758	645	947	932
1 000	95,5	15,2	0,0176	0,0235	0,25	1 062	1 140	1 297	1 287	808	700	1 059	1 026
1 200	99,5	17,1	0,0151	0,0205	0,26	1 135	1 222	1 405	1 389	847	730	1 130	1 087
1 600	105,0	21,2	0,0113	0,0161	0,29	1 265	1 446	1 605	1 569	906	751	1 244	1 184
2 000	111,5	25,4	0,0090	0,0135	0,31	1 368	1 582	1 776	1 723	954	789	1 344	1 268
2 500	118,5	30,5	0,0072	0,0117	0,33	1 449	1 700	1 933	1 854	981	822	1 420	1 335



Um = 170 kV

Sections mm <sup>2</sup>	Overall diameter mm	Weight (Kg/m)	DC conductor resistance at 20 °C Ω/km	AC apparent conductor resistance at 90 °C	Capacitance µF/km	CONTINUOUS CURRENT RATING, A Earthing at one point				CONTINUOUS CURRENT RATING, A Earthing in several points			
						Direct buried	Pulled in ducts	In air, trefoil Exposed to solar radiation (*)	In air, flat Exposed to solar radiation (*)	Direct buried	Pulled in ducts	In air, trefoil Exposed to solar radiation (*)	In air, flat Exposed to solar radiation (*)
300	68,5	3,5	0,1000	0,1290	0,17	457	470	501	515	430	401	482	491
400	72,5	4	0,0778	0,1008	0,18	520	538	580	595	483	444	552	560
500	78,5	4,8	0,0605	0,0789	0,20	592	613	670	685	539	489	629	635
630	81	5,4	0,0469	0,0617	0,22	672	700	777	791	601	535	719	722
800	86,5	7,3	0,0367	0,0494	0,23	755	791	888	901	660	581	808	807
1 000	94,5	8,7	0,0291	0,0404	0,24	839	883	1 007	1 018	716	626	901	894
1 200	98,5	9,4	0,0247	0,0353	0,26	900	949	1 093	1 101	758	658	968	956
1 600	104	11,1	0,0186	0,0241	0,28	1 074	1 179	1 343	1 337	827	703	1 108	1 072
2 000	110,5	12,8	0,0149	0,0195	0,31	1 191	1 316	1 531	1 512	888	751	1 228	1 177
2 500	117,5	14,1	0,0127	0,0166	0,32	1 265	1 413	1 650	1 614	914	774	1 288	1 230

[\*] Without exposure to direct solar radiation, we consider the ampacity is about 20% higher



**Um = 245 kV**

Sections mm <sup>2</sup>	Overall diameter mm	Weight (Kg/m)	DC conductor resistance at 20 °C Ω/km	AC apparent conductor resistance at 90 °C	Capacitance μF/km	CONTINUOUS CURRENT RATING, A Earthing at one point				CONTINUOUS CURRENT RATING, A Earthing in several points			
						Direct buried	Pulled in ducts	In air, trefoil Exposed to solar radiation (*)	In air, flat Exposed to solar radiation (*)	Direct buried	Pulled in ducts	In air, trefoil Exposed to solar radiation (*)	In air, flat Exposed to solar radiation (*)
400	90,0	9,3	0,0470	0,0617	0,14	652	672	718	732	588	531	674	679
500	91,0	10,3	0,0366	0,0490	0,16	736	766	831	844	646	575	765	766
630	94,5	11,9	0,0283	0,0391	0,17	826	865	949	960	707	620	858	853
800	99,0	13,9	0,0221	0,0320	0,18	914	964	1 070	1 076	766	665	952	940
1 000	106,5	16,8	0,0176	0,0235	0,20	1 062	1 164	1 280	1 276	821	704	1 072	1 042
1 200	111,5	18,9	0,0151	0,0204	0,21	1 136	1 249	1 387	1 377	862	734	1 146	1 107
1 600	117,0	23,1	0,0113	0,0160	0,22	1 261	1 413	1 583	1 553	915	777	1 258	1 204
2 000	124,0	27,4	0,0090	0,0134	0,24	1 366	1 541	1 755	1 709	963	818	1 360	1 292
2 500	131,5	32,9	0,0072	0,0115	0,25	1 448	1 759	1 912	1 841	991	824	1 441	1 364



**Um = 245 kV**

Sections mm <sup>2</sup>	Overall diameter mm	Weight (Kg/m)	DC conductor resistance at 20 °C Ω/km	AC apparent conductor resistance at 90 °C	Capacitance μF/km	CONTINUOUS CURRENT RATING, A Earthing at one point				CONTINUOUS CURRENT RATING, A Earthing in several points			
						Direct buried	Pulled in ducts	In air, trefoil Exposed to solar radiation (*)	In air, flat Exposed to solar radiation (*)	Direct buried	Pulled in ducts	In air, trefoil Exposed to solar radiation (*)	In air, flat Exposed to solar radiation (*)
400	89	6,9	0,0778	0,1007	0,14	517	528	567	582	483	451	545	554
500	90	7,2	0,0605	0,0788	0,16	589	604	659	674	539	495	624	632
630	93,5	7,9	0,0469	0,0618	0,17	670	690	765	780	602	545	715	720
800	98	8,8	0,0367	0,0492	0,18	753	778	874	888	664	594	806	807
1 000	105,5	10,4	0,0291	0,0402	0,19	838	898	993	1 005	724	630	903	898
1 200	110,5	11,2	0,0247	0,0351	0,20	900	967	1 077	1 088	768	662	972	963
1 600	116	13	0,0186	0,0241	0,22	1 068	1 155	1 318	1 315	832	723	1 110	1 081
2 000	123	14,8	0,0149	0,0195	0,24	1 185	1 287	1 503	1 488	893	774	1 233	1 189
2 500	130,5	16,5	0,0127	0,0166	0,25	1 258	1 380	1 619	1 589	920	802	1 296	1 245

[\*] Without exposure to direct solar radiation, we consider the ampacity is about 20% higher



Um = 362 kV

Sections mm <sup>2</sup>	Overall diameter mm	Weight (Kg/m)	DC conductor resistance at 20 °C Ω/km	AC apparent conductor resistance at 90 °C	Capacitance µF/km	CONTINUOUS CURRENT RATING, A Earthing at one point				CONTINUOUS CURRENT RATING, A Earthing in several points			
						Direct buried	Pulled in ducts	In air, trefoil Exposed to solar radiation (*)	In air, flat Exposed to solar radiation (*)	Direct buried	Pulled in ducts	In air, trefoil Exposed to solar radiation (*)	In air, flat Exposed to solar radiation (*)
630	97,0	11,1	0,0283	0,0390	0,16	811	853	936	942	688	619	842	843
800	102,0	13,2	0,0221	0,0319	0,18	893	984	1 053	1 052	740	658	931	928
1 000	108,5	15,9	0,0176	0,0234	0,19	1 024	1 143	1 252	1 233	781	713	1 039	1 028
1 200	114,0	18,0	0,0151	0,0204	0,20	1 083	1 220	1 347	1 317	811	743	1 101	1 088
1 600	120,0	22,4	0,0113	0,0159	0,22	1 197	1 371	1 530	1 477	862	785	1 208	1 187
2 000	127,0	26,8	0,0090	0,0134	0,23	1 284	1 582	1 686	1 610	899	815	1 296	1 267
2 500	133,5	33,6	0,0072	0,0114	0,25	1 362	1 707	1 837	1 737	931	841	1 379	1 341



Um = 362 kV

Sections mm <sup>2</sup>	Overall diameter mm	Weight (Kg/m)	DC conductor resistance at 20 °C Ω/km	AC apparent conductor resistance at 90 °C	Capacitance µF/km	CONTINUOUS CURRENT RATING, A Earthing at one point				CONTINUOUS CURRENT RATING, A Earthing in several points			
						Direct buried	Pulled in ducts	In air, trefoil Exposed to solar radiation (*)	In air, flat Exposed to solar radiation (*)	Direct buried	Pulled in ducts	In air, trefoil Exposed to solar radiation (*)	In air, flat Exposed to solar radiation (*)
630	96	7,1	0,0469	0,0617	0,17	660	681	756	769	589	543	704	712
800	101	8,1	0,0367	0,0493	0,18	739	792	863	873	645	590	792	798
1 000	107,5	9,4	0,0291	0,0402	0,19	817	886	978	982	697	637	882	888
1 200	113	10,3	0,0247	0,0350	0,20	871	950	1 057	1 056	733	669	944	949
1 600	119	12,3	0,0186	0,0241	0,21	1 026	1 129	1 284	1 265	791	730	1 074	1 068
2 000	126	14,2	0,0149	0,0195	0,23	1 128	1 316	1 455	1 419	841	772	1 183	1 169
2 500	131,5	17,2	0,0127	0,0166	0,24	1 197	1 415	1 569	1 518	871	795	1 248	1 228

[\*] Without exposure to direct solar radiation, we consider the ampacity is about 20% higher



**Um = 420 kV**

Sections mm <sup>2</sup>	Overall diametre mm	Weight (Kg/m)	DC conductor resistance at 20 °C Ω/km	AC apparent conductor resistance at 90 °C	Capacitance µF/km	CONTINUOUS CURRENT RATING, A Earthing at one point				CONTINUOUS CURRENT RATING, A Earthing in several points			
						Direct buried	Pulled in ducts	In air, trefoil Exposed to solar radiation (*)	In air, flat Exposed to solar radiation (*)	Direct buried	Pulled in ducts	In air, trefoil Exposed to solar radiation (*)	In air, flat Exposed to solar radiation (*)
630	111,0	13,1	0,0283	0,0389	0,14	803	863	917	922	690	633	839	846
800	111,5	14,6	0,0221	0,0317	0,16	885	967	1 038	1 036	740	672	929	932
1 000	117,5	17,3	0,0176	0,0234	0,17	1 013	1 121	1 233	1 215	782	725	1 040	1 036
1 200	120,5	19,2	0,0151	0,0204	0,18	1 078	1 200	1 334	1 307	813	747	1 103	1 093
1 600	138,5	27,4	0,0113	0,0159	0,19	1 192	1 425	1 517	1 469	864	789	1 213	1 193
2 000	134,0	29,6	0,0090	0,0133	0,21	1 279	1 555	1 672	1 603	902	819	1 303	1 276
2 500	141,5	35,1	0,0072	0,0113	0,22	1 362	1 674	1 827	1 736	936	846	1 390	1 353



**Um = 420 kV**

Sections mm <sup>2</sup>	Overall diametre mm	Weight (Kg/m)	DC conductor resistance at 20 °C Ω/km	AC apparent conductor resistance at 90 °C	Capacitance µF/km	CONTINUOUS CURRENT RATING, A Earthing at one point				CONTINUOUS CURRENT RATING, A Earthing in several points			
						Direct buried	Pulled in ducts	In air, trefoil Exposed to solar radiation (*)	In air, flat Exposed to solar radiation (*)	Direct buried	Pulled in ducts	In air, trefoil Exposed to solar radiation (*)	In air, flat Exposed to solar radiation (*)
630	109,5	9,1	0,0469	0,0617	0,14	654	688	740	751	589	554	696	708
800	110,5	9,5	0,0367	0,0492	0,16	733	780	849	858	644	599	786	796
1 000	116,5	10,8	0,0291	0,0400	0,17	811	871	964	968	697	644	878	887
1 200	119,5	11,5	0,0247	0,0348	0,18	867	937	1 045	1 046	734	671	941	947
1 600	137,5	17,0	0,0186	0,0241	0,19	1 021	1 163	1 270	1 254	791	734	1 074	1 069
2 000	133,0	17,3	0,0149	0,0194	0,20	1 122	1 296	1 439	1 407	842	775	1 184	1 171
2 500	140,5	18,7	0,0127	0,0166	0,21	1 194	1 391	1 553	1 508	874	798	1 252	1 232

[\*] Without exposure to direct solar radiation, we consider the ampacity is about 20% higher



Um = 550 kV

Sections mm <sup>2</sup>	Overall diameter mm	Weight (Kg/m)	DC conductor resistance at 20 °C Ω/km	AC apparent conductor resistance at 90 °C	Capacitance µF/km	CONTINUOUS CURRENT RATING, A Earthing at one point				CONTINUOUS CURRENT RATING, A Earthing in several points			
						Direct buried	Pulled in ducts	In air, trefoil Exposed to solar radiation (*)	In air, flat Exposed to solar radiation (*)	Direct buried	Pulled in ducts	In air, trefoil Exposed to solar radiation (*)	In air, flat Exposed to solar radiation (*)
800	119,5	18,8	0,0221	0,0316	0,15	875	949	1 024	1 023	737	676	925	932
1 000	128,0	19,2	0,0176	0,0234	0,16	1 006	1 146	1 214	1 201	784	730	1 039	1 037
1 200	132,0	21,3	0,0151	0,0203	0,16	1 066	1 228	1 310	1 287	814	759	1 104	1 100
1 600	140,0	27,5	0,0113	0,0158	0,17	1 180	1 387	1 492	1 449	866	799	1 217	1 204
2 000	145,0	31,9	0,0090	0,0132	0,18	1 270	1 511	1 649	1 588	904	828	1 310	1 288
2 500	152,5	37,5	0,0072	0,0113	0,19	1 352	1 623	1 804	1 722	938	856	1 399	1 368



Um = 550 kV

Sections mm <sup>2</sup>	Overall diameter mm	Weight (Kg/m)	DC conductor resistance at 20 °C Ω/km	AC apparent conductor resistance at 90 °C	Capacitance µF/km	CONTINUOUS CURRENT RATING, A Earthing at one point				CONTINUOUS CURRENT RATING, A Earthing in several points			
						Direct buried	Pulled in ducts	In air, trefoil Exposed to solar radiation (*)	In air, flat Exposed to solar radiation (*)	Direct buried	Pulled in ducts	In air, trefoil Exposed to solar radiation (*)	In air, flat Exposed to solar radiation (*)
800	118,5	13,7	0,0367	0,0491	0,15	725	766	836	845	640	600	779	791
1 000	127,0	12,7	0,0291	0,0399	0,15	805	886	947	953	697	649	872	882
1 200	131,0	13,6	0,0247	0,0347	0,16	859	988	1 025	1 028	733	693	935	944
1 600	139,0	17,4	0,0186	0,0241	0,17	1 009	1 136	1 169	1 232	791	741	1 020	1 070
2 000	144,0	19,3	0,0149	0,0194	0,18	1 109	1 263	1 412	1 386	841	780	1 182	1 174
2 500	151,5	21,1	0,0127	0,0166	0,19	1 182	1 354	1 526	1 487	874	804	1 252	1 237

[\*] Without exposure to direct solar radiation, we consider the ampacity is about 20% higher

# COPPER WIRES WITH LEAD SHEATH

(Specified and tested according to IEC 60840 and IEC 62067)

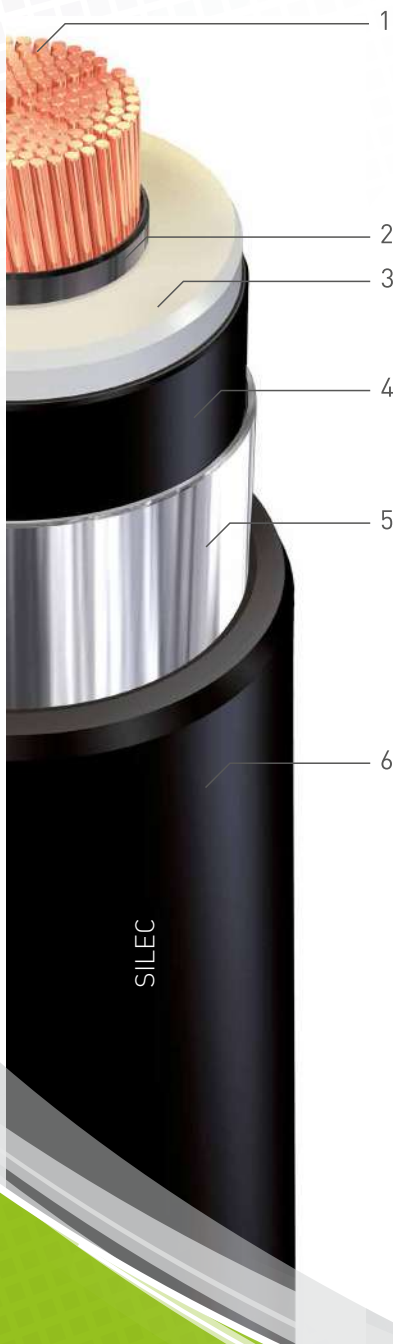

**Range of voltage  $U_m$ : 72,5 kV to 550 kV**

**Range of cross-section: 240 mm<sup>2</sup> to 2 500 mm<sup>2</sup> copper or aluminium**

## CONSTRUCTION:

### 1. CONDUCTOR

Annealed copper - Class 2

Aluminium - Class 2

Concentric conductor  $\leq 1\ 000\ \text{mm}^2$

Milliken or optimized Milliken conductor  $\geq 1\ 200\ \text{mm}^2$

### 2. INNER SEMI-CONDUCTOR LAYER

Extruded semi-conducting compound

### 3. INSULATION

Cross-Linked Polyethylene [XLPE]

### 4. OUTER SEMI-CONDUCTOR LAYER

Extruded semi-conducting compound

### 5. SCREEN

Copper wires and lead sheath

### 6. SHEATH

HDPE or halogen-free fire-retardant oversheath

Optional: conductive coating



Um = 72,5 kV

Sections mm <sup>2</sup>	Overall diameter mm	Weight (Kg/m)	DC conductor resistance at 20 °C Ω/km	AC apparent conductor resistance at 90 °C	Capacitance µF/km	CONTINUOUS CURRENT RATING, A Earthing at one point				CONTINUOUS CURRENT RATING, A Earthing in several points			
						Direct buried	Pulled in ducts	In air, trefoil Exposed to solar radiation (*)	In air, flat Exposed to solar radiation (*)	Direct buried	Pulled in ducts	In air, trefoil Exposed to solar radiation (*)	In air, flat Exposed to solar radiation (*)
240	59,0	9,6	0,0754	0,0974	0,23	535	551	590	611	526	506	583	600
300	61,5	10,4	0,0601	0,0783	0,25	604	622	675	699	591	560	664	682
400	63,0	11,4	0,0470	0,0622	0,27	685	708	777	805	666	621	760	780
500	68,5	13,0	0,0366	0,0496	0,31	778	806	900	932	749	688	875	894
630	72,0	14,8	0,0283	0,0399	0,34	877	914	1 031	1 067	835	755	994	1 011
800	76,0	16,9	0,0221	0,0329	0,37	976	1 026	1 171	1 210	918	819	1 118	1 131
1 000	82,5	19,7	0,0176	0,0237	0,42	1 161	1 205	1 433	1 476	1 046	909	1 322	1 311
1 200	87,0	22,1	0,0151	0,0207	0,45	1 248	1 298	1 558	1 602	1 105	954	1 418	1 397
1 600	93,0	26,7	0,0113	0,0163	0,47	1 412	1 479	1 796	1 837	1 209	1 033	1 591	1 546
2 000	100,0	31,1	0,0090	0,0137	0,52	1 542	1 626	2 007	2 044	1 280	1 095	1 732	1 663



Um = 72,5 kV

Sections mm <sup>2</sup>	Overall diameter mm	Weight (Kg/m)	DC conductor resistance at 20 °C Ω/km	AC apparent conductor resistance at 90 °C	Capacitance µF/km	CONTINUOUS CURRENT RATING, A Earthing at one point				CONTINUOUS CURRENT RATING, A Earthing in several points			
						Direct buried	Pulled in ducts	In air, trefoil Exposed to solar radiation (*)	In air, flat Exposed to solar radiation (*)	Direct buried	Pulled in ducts	In air, trefoil Exposed to solar radiation (*)	In air, flat Exposed to solar radiation (*)
240	57,5	8,0	0,1250	0,1609	0,23	415	428	459	476	390	365	439	448
300	59,5	8,5	0,1000	0,1290	0,25	471	483	527	546	437	453	522	538
400	61,5	8,9	0,0778	0,1009	0,27	538	553	610	633	529	509	602	620
500	66,5	10	0,0605	0,0791	0,31	616	632	710	736	601	570	697	717
630	70,5	10,8	0,0469	0,0621	0,34	704	724	828	859	682	637	809	829
800	74,5	11,8	0,0367	0,0497	0,37	796	821	954	988	763	703	924	944
1 000	80	13,0	0,0291	0,0407	0,41	890	922	1 090	1 129	844	767	1 047	1 063
1 200	83,5	14,1	0,0247	0,0356	0,44	957	994	1 185	1 226	899	812	1 131	1 144
1 600	92	16,5	0,0186	0,0241	0,47	1 169	1 198	1 480	1 525	1 045	920	1 358	1 345
2 000	99	18,5	0,0149	0,0195	0,53	1 312	1 344	1 706	1 750	1 166	996	1 527	1 492

[\*] Without exposure to direct solar radiation, we consider the ampacity is about 20% higher



**Um = 123 kV**

Sections mm <sup>2</sup>	Overall diameter mm	Weight (Kg/m)	DC conductor resistance at 20 °C Ω/km	AC apparent conductor resistance at 90 °C	Capacitance µF/km	CONTINUOUS CURRENT RATING, A Earthing at one point				CONTINUOUS CURRENT RATING, A Earthing in several points			
						Direct buried	Pulled in ducts	In air, trefoil Exposed to solar radiation (*)	In air, flat Exposed to solar radiation (*)	Direct buried	Pulled in ducts	In air, trefoil Exposed to solar radiation (*)	In air, flat Exposed to solar radiation (*)
240	72,5	11,8	0,0754	0,0973	0,15	531	541	576	595	521	501	569	585
300	74,0	12,5	0,0601	0,0781	0,17	599	611	660	682	585	556	650	666
400	75,0	13,3	0,0470	0,0619	0,19	681	697	761	787	660	618	746	763
500	77,5	14,7	0,0366	0,0493	0,22	775	795	885	915	744	686	861	878
630	81,0	16,5	0,0283	0,0395	0,24	874	902	1 015	1 048	830	755	979	994
800	86,5	18,9	0,0221	0,0324	0,25	975	1 010	1 150	1 186	913	821	1 100	1 110
1 000	93,0	21,7	0,0176	0,0236	0,28	1 155	1 187	1 400	1 440	1 035	914	1 295	1 283
1 200	97,5	24,2	0,0151	0,0206	0,30	1 241	1 278	1 523	1 562	1 092	961	1 389	1 367
1 600	104,0	28,8	0,0113	0,0162	0,32	1 406	1 506	1 757	1 794	1 195	992	1 561	1 517
2 000	110,0	33,3	0,0090	0,0136	0,35	1 538	1 663	1 966	1 998	1 267	1 046	1 704	1 638



**Um = 123 kV**

Sections mm <sup>2</sup>	Overall diameter mm	Weight (Kg/m)	DC conductor resistance at 20 °C Ω/km	AC apparent conductor resistance at 90 °C	Capacitance µF/km	CONTINUOUS CURRENT RATING, A Earthing at one point				CONTINUOUS CURRENT RATING, A Earthing in several points			
						Direct buried	Pulled in ducts	In air, trefoil Exposed to solar radiation (*)	In air, flat Exposed to solar radiation (*)	Direct buried	Pulled in ducts	In air, trefoil Exposed to solar radiation (*)	In air, flat Exposed to solar radiation (*)
240	71,5	10,3	0,1250	0,1609	0,15	414	420	449	465	409	401	446	460
300	73	10,6	0,1000	0,1290	0,16	468	475	515	533	461	448	510	525
400	74	10,9	0,0778	0,1008	0,19	535	545	598	638	525	505	591	625
500	76,5	11,6	0,0605	0,0789	0,22	612	624	697	721	597	567	685	703
630	80	12,5	0,0469	0,0618	0,24	700	715	813	841	677	634	794	813
800	85,5	13,8	0,0367	0,0497	0,25	792	809	933	965	758	701	905	923
1 000	92	15,3	0,0291	0,0404	0,28	887	908	1 067	1 102	839	768	1 026	1 041
1 200	96,5	16,5	0,0247	0,0353	0,30	954	979	1 161	1 198	893	814	1 108	1 120
1 600	103	18,7	0,0186	0,0241	0,32	1 160	1 215	1 442	1 482	1 033	892	1 327	1 313
2 000	109	20,7	0,0149	0,0195	0,35	1 303	1 367	1 662	1 702	1 125	959	1 494	1 461

[\*] Without exposure to direct solar radiation, we consider the ampacity is about 20% higher



Um = 145 k

Sections mm <sup>2</sup>	Overall diameter mm	Weight (Kg/m)	DC conductor resistance at 20 °C Ω/km	AC apparent conductor resistance at 90 °C	Capacitance µF/km	CONTINUOUS CURRENT RATING, A Earthing at one point				CONTINUOUS CURRENT RATING, A Earthing in several points			
						Direct buried	Pulled in ducts	In air, trefoil Exposed to solar radiation (*)	In air, flat Exposed to solar radiation (*)	Direct buried	Pulled in ducts	In air, trefoil Exposed to solar radiation (*)	In air, flat Exposed to solar radiation (*)
240	67,0	11,3	0,0754	0,0973	0,17	532	544	581	601	522	502	574	590
300	70,5	12,4	0,0601	0,0782	0,18	600	613	663	686	586	556	653	670
400	73,5	13,5	0,0470	0,0619	0,19	682	698	765	791	661	619	750	767
500	79,0	15,3	0,0366	0,0493	0,21	774	794	883	912	743	686	859	876
630	82,5	17,1	0,0283	0,0395	0,23	973	902	1 012	1 045	829	756	977	991
800	87,5	19,5	0,0221	0,0324	0,25	974	1 008	1 148	1 184	912	821	1 097	1 108
1 000	94,0	22,3	0,0176	0,0236	0,27	1 153	1 184	1 397	1 435	1 033	914	1 292	1 280
1 200	99,5	25,0	0,0151	0,0206	0,28	1 239	1 273	1 516	1 555	1 089	961	1 383	1 362
1 600	105,0	29,5	0,0113	0,0161	0,31	1 404	1 502	1 752	1 789	1 192	992	1 558	1 514
2 000	112,0	34,2	0,0090	0,0136	0,33	1 535	1 656	1 957	1 988	1 264	1 047	1 699	1 632



Um = 145 kV

Sections mm <sup>2</sup>	Overall diameter mm	Weight (Kg/m)	DC conductor resistance at 20 °C Ω/km	AC apparent conductor resistance at 90 °C	Capacitance µF/km	CONTINUOUS CURRENT RATING, A Earthing at one point				CONTINUOUS CURRENT RATING, A Earthing in several points			
						Direct buried	Pulled in ducts	In air, trefoil Exposed to solar radiation (*)	In air, flat Exposed to solar radiation (*)	Direct buried	Pulled in ducts	In air, trefoil Exposed to solar radiation (*)	In air, flat Exposed to solar radiation (*)
240	66	9,8	0,1250	0,1609	0,15	414	423	453	469	410	402	450	464
300	69,5	10,5	0,1000	0,1290	0,16	468	477	517	535	461	448	512	528
400	72,5	11,1	0,0778	0,1008	0,19	536	546	602	623	525	505	594	611
500	78	12,2	0,0605	0,0789	0,22	611	623	695	719	596	566	683	701
630	81,5	13,1	0,0469	0,0617	0,24	699	714	810	839	676	634	792	810
800	86,5	14,4	0,0367	0,0497	0,25	791	807	931	963	757	701	903	921
1 000	93	15,8	0,0291	0,0404	0,28	886	906	1 064	1 100	837	767	1 024	1 039
1 200	98,5	17,3	0,0247	0,0353	0,30	935	976	1 156	1 192	892	814	1 104	1 116
1 600	104	19,4	0,0186	0,0241	0,32	1 159	1 212	1 438	1 478	1 031	892	1 324	1 310
2 000	111	21,6	0,0149	0,0195	0,35	1 300	1 362	1 653	1 692	1 122	960	1 488	1 455

[\*] Without exposure to direct solar radiation, we consider the ampacity is about 20% higher



**Um = 170 kV**

Sections mm <sup>2</sup>	Overall diametre mm	Weight (Kg/m)	DC conductor resistance at 20 °C Ω/km	AC apparent conductor resistance at 90 °C	Capacitance µF/km	CONTINUOUS CURRENT RATING, A Earthing at one point				CONTINUOUS CURRENT RATING, A Earthing in several points			
						Direct buried	Pulled in ducts	In air, trefoil Exposed to solar radiation (*)	In air, flat Exposed to solar radiation (*)	Direct buried	Pulled in ducts	In air, trefoil Exposed to solar radiation (*)	In air, flat Exposed to solar radiation (*)
300	74,0	13,5	0,0601	0,0781	0,17	600	612	662	685	585	556	652	669
400	77,5	14,8	0,0470	0,0619	0,18	682	696	763	789	660	619	748	765
500	83,0	16,6	0,0366	0,0492	0,19	773	791	880	908	742	686	856	872
630	86,0	18,4	0,0283	0,0393	0,21	873	897	1 009	1 041	828	755	974	988
800	91,5	20,8	0,0221	0,0323	0,23	974	1 004	1 144	1 179	911	822	1 094	1 104
1 000	99,0	24,0	0,0176	0,0235	0,25	1 152	1 177	1 387	1 424	1 028	917	1 282	1 271
1 200	103,5	26,4	0,0151	0,0205	0,26	1 238	1 307	1 509	1 546	1 086	926	1 378	1 356
1 600	108,5	30,9	0,0113	0,0161	0,29	1 403	1 495	1 744	1 780	1 188	995	1 552	1 508
2 000	116,0	35,6	0,0090	0,0135	0,31	1 535	1 648	1 949	1 979	1 260	1 052	1 693	1 627
2 500	123,0	41,4	0,0072	0,0117	0,33	1 658	1 794	2 153	2 175	1 320	1 103	1 824	1 734



**Um = 170 kV**

Sections mm <sup>2</sup>	Overall diametre mm	Weight (Kg/m)	DC conductor resistance at 20 °C Ω/km	AC apparent conductor resistance at 90 °C	Capacitance µF/km	CONTINUOUS CURRENT RATING, A Earthing at one point				CONTINUOUS CURRENT RATING, A Earthing in several points			
						Direct buried	Pulled in ducts	In air, trefoil Exposed to solar radiation (*)	In air, flat Exposed to solar radiation (*)	Direct buried	Pulled in ducts	In air, trefoil Exposed to solar radiation (*)	In air, flat Exposed to solar radiation (*)
300	73	11,6	0,1000	0,1290	0,17	468	476	517	535	461	448	512	527
400	76,5	12,4	0,0778	0,1008	0,18	535	544	600	621	525	505	592	609
500	82	13,5	0,0605	0,0789	0,20	611	621	692	716	595	566	680	698
630	85	14,4	0,0469	0,0617	0,22	699	711	807	835	675	634	789	807
800	90,5	15,7	0,0367	0,0497	0,23	790	804	927	958	755	701	900	916
1 000	98	17,6	0,0291	0,0404	0,24	885	902	1 057	1 092	835	769	1 017	1 031
1 200	102,5	18,7	0,0247	0,0353	0,26	953	1 001	1 151	1 187	891	796	1 100	1 111
1 600	107,5	20,8	0,0186	0,0241	0,28	1 157	1 207	1 430	1 469	1 028	894	1 318	1 304
2 000	115	23	0,0149	0,0195	0,31	1 298	1 356	1 643	1 681	1 118	963	1 480	1 448
2 500	122	25	0,0127	0,0166	0,32	1 400	1 467	1 792	1 827	1 179	1 006	1 587	1 540

[\*] Without exposure to direct solar radiation, we consider the ampacity is about 20% higher



Um = 245 kV

Sections mm <sup>2</sup>	Overall diameter mm	Weight (Kg/m)	DC conductor resistance at 20 °C Ω/km	AC apparent conductor resistance at 90 °C	Capacitance µF/km	CONTINUOUS CURRENT RATING, A Earthing at one point				CONTINUOUS CURRENT RATING, A Earthing in several points			
						Direct buried	Pulled in ducts	In air, trefoil Exposed to solar radiation (*)	In air, flat Exposed to solar radiation (*)	Direct buried	Pulled in ducts	In air, trefoil Exposed to solar radiation (*)	In air, flat Exposed to solar radiation (*)
400	95,0	18,1	0,0470	0,0617	0,14	675	682	740	764	652	616	726	741
500	94,5	18,9	0,0366	0,0490	0,16	768	779	861	888	735	685	839	854
630	98,5	20,9	0,0283	0,0391	0,17	868	882	987	1 017	821	755	954	967
800	103,5	23,3	0,0221	0,0320	0,18	970	1 016	1 121	1 153	904	803	1 073	1 083
1 000	110,5	26,5	0,0176	0,0235	0,19	1 143	1 192	1 354	1 389	1 015	889	1 256	1 245
1 200	116,0	29,2	0,0151	0,0204	0,21	1 229	1 284	1 470	1 505	1 072	932	1 348	1 328
1 600	121,0	33,8	0,0113	0,0160	0,22	1 393	1 466	1 701	1 733	1 172	1 005	1 521	1 479
2 000	128,5	38,7	0,0090	0,0134	0,24	1 524	1 680	1 902	1 928	1 243	1 006	1 661	1 599
2 500	136,5	45,0	0,0072	0,0115	0,25	1 648	1 834	2 100	2 118	1 301	1 051	1 791	1 706



Um = 245 kV

Sections mm <sup>2</sup>	Overall diameter mm	Weight (Kg/m)	DC conductor resistance at 20 °C Ω/km	AC apparent conductor resistance at 90 °C	Capacitance µF/km	CONTINUOUS CURRENT RATING, A Earthing at one point				CONTINUOUS CURRENT RATING, A Earthing in several points			
						Direct buried	Pulled in ducts	In air, trefoil Exposed to solar radiation (*)	In air, flat Exposed to solar radiation (*)	Direct buried	Pulled in ducts	In air, trefoil Exposed to solar radiation (*)	In air, flat Exposed to solar radiation (*)
400	93,5	15,7	0,0778	0,1008	0,14	530	533	581	600	519	500	574	589
500	94,5	15,9	0,0605	0,0789	0,16	606	611	677	700	590	562	666	682
630	98,5	17	0,0469	0,0617	0,17	694	700	788	814	669	631	771	788
800	103,5	18,2	0,0367	0,0497	0,18	785	813	906	935	749	690	880	896
1 000	110,5	20,1	0,0291	0,0404	0,19	880	913	1 033	1 065	829	754	996	1 010
1 200	116	21,5	0,0247	0,0353	0,2	948	984	1 123	1 157	885	797	1 076	1 087
1 600	121	23,7	0,0186	0,0241	0,22	1 147	1 186	1 390	1 426	1 014	898	1 286	1 273
2 000	128,5	26,1	0,0149	0,0195	0,24	1 286	1 377	1 597	1 631	1 102	928	1 445	1 416
2 500	136,5	28,6	0,0127	0,0166	0,25	1 386	1 490	1 737	1 769	1 161	966	1 548	1 505

[\*] Without exposure to direct solar radiation, we consider the ampacity is about 20% higher



**Um = 362 kV**

Sections mm <sup>2</sup>	Overall diametre mm	Weight (Kg/m)	DC conductor resistance at 20 °C Ω/km	AC apparent conductor resistance at 90 °C	Capacitance µF/km	CONTINUOUS CURRENT RATING, A Earthing at one point				CONTINUOUS CURRENT RATING, A Earthing in several points			
						Direct buried	Pulled in ducts	In air, trefoil Exposed to solar radiation (*)	In air, flat Exposed to solar radiation (*)	Direct buried	Pulled in ducts	In air, trefoil Exposed to solar radiation (*)	In air, flat Exposed to solar radiation (*)
630	101,5	23,0	0,0283	0,0390	0,16	863	898	981	1 011	815	737	948	962
800	106,5	25,5	0,0221	0,0319	0,17	964	1 007	1 115	1 147	897	800	1 068	1 077
1 000	112,5	28,5	0,0176	0,0234	0,19	1 135	1 182	1 347	1 382	1 007	884	1 250	1 239
1 200	118,0	31,2	0,0151	0,0204	0,20	1 219	1 271	1 463	1 498	1 062	926	1 341	1 322
1 600	124,0	36,0	0,0113	0,0159	0,21	1 381	1 450	1 690	1 721	1 161	1 001	1 511	1 471
2 000	131,5	40,9	0,0090	0,0134	0,23	1 511	1 662	1 889	1 915	1 230	1 001	1 651	1 589
2 500	138,5	47,0	0,0072	0,0114	0,25	1 633	1 815	2 090	2 108	1 287	1 044	1 782	1 698



**Um = 362 kV**

Sections mm <sup>2</sup>	Overall diametre mm	Weight (Kg/m)	DC conductor resistance at 20 °C Ω/km	AC apparent conductor resistance at 90 °C	Capacitance µF/km	CONTINUOUS CURRENT RATING, A Earthing at one point				CONTINUOUS CURRENT RATING, A Earthing in several points			
						Direct buried	Pulled in ducts	In air, trefoil Exposed to solar radiation (*)	In air, flat Exposed to solar radiation (*)	Direct buried	Pulled in ducts	In air, trefoil Exposed to solar radiation (*)	In air, flat Exposed to solar radiation (*)
630	101,5	19,0	0,0469	0,0617	0,17	689	711	783	809	664	622	766	783
800	106,5	20,4	0,0367	0,0497	0,18	780	806	900	929	744	686	875	891
1 000	112,5	22,1	0,0291	0,0404	0,19	874	905	1 029	1 061	823	749	992	1 005
1 200	118,0	23,5	0,0247	0,0353	0,20	941	975	1 118	1 152	878	792	1 071	1 082
1 600	124,0	25,9	0,0186	0,0241	0,21	1 137	1 174	1 380	1 416	1 004	893	1 277	1 265
2 000	131,5	28,3	0,0149	0,0195	0,23	1 274	1 363	1 585	1 619	1 091	923	1 435	1 406
2 500	138,5	30,6	0,0127	0,0166	0,24	1 373	1 475	1 728	1 760	1 149	960	1 540	1 497

[\*] Without exposure to direct solar radiation, we consider the ampacity is about 20% higher



Um = 420 kV

Sections mm <sup>2</sup>	Overall diameter mm	Weight (Kg/m)	DC conductor resistance at 20 °C Ω/km	AC apparent conductor resistance at 90 °C	Capacitance µF/km	CONTINUOUS CURRENT RATING, A Earthing at one point				CONTINUOUS CURRENT RATING, A Earthing in several points			
						Direct buried	Pulled in ducts	In air, trefoil Exposed to solar radiation (*)	In air, flat Exposed to solar radiation (*)	Direct buried	Pulled in ducts	In air, trefoil Exposed to solar radiation (*)	In air, flat Exposed to solar radiation (*)
630	115,5	26,2	0,0283	0,0389	0,14	857	882	958	986	807	737	927	940
800	116,0	27,7	0,0221	0,0317	0,15	958	993	1 095	1 126	890	800	1 050	1 060
1 000	121,5	30,5	0,0176	0,0234	0,17	1 125	1 164	1 322	1 355	995	884	1 229	1 219
1 200	125,0	32,9	0,0151	0,0204	0,18	1 210	1 255	1 440	1 474	1 051	927	1 323	1 305
1 600	131,0	37,8	0,0113	0,0159	0,19	1 370	1 484	1 664	1 694	1 148	954	1 491	1 453
2 000	138,5	42,8	0,0090	0,0133	0,20	1 499	1 638	1 861	1 886	1 216	1 003	1 630	1 572
2 500	146,5	49,2	0,0072	0,0113	0,22	1 620	1 785	2 056	2 073	1 272	1 048	1 759	1 679



Um = 420 kV

Sections mm <sup>2</sup>	Overall diameter mm	Weight (Kg/m)	DC conductor resistance at 20 °C Ω/km	AC apparent conductor resistance at 90 °C	Capacitance µF/km	CONTINUOUS CURRENT RATING, A Earthing at one point				CONTINUOUS CURRENT RATING, A Earthing in several points			
						Direct buried	Pulled in ducts	In air, trefoil Exposed to solar radiation (*)	In air, flat Exposed to solar radiation (*)	Direct buried	Pulled in ducts	In air, trefoil Exposed to solar radiation (*)	In air, flat Exposed to solar radiation (*)
630	115,5	22,2	0,0469	0,0617	0,14	684	699	763	788	658	620	748	764
800	116	22,3	0,0367	0,0497	0,15	775	795	883	911	738	684	859	875
1 000	121,5	24,0	0,0291	0,0404	0,17	868	893	1 010	1 041	816	748	975	989
1 200	125	25,2	0,0247	0,0353	0,18	935	964	1 101	1 134	871	791	1 057	1 068
1 600	131	27,7	0,0186	0,0241	0,19	1 128	1 197	1 358	1 392	994	862	1 258	1 247
2 000	138,5	30,2	0,0149	0,0195	0,20	1 263	1 345	1 558	1 592	1 079	923	1 414	1 388
2 500	146,5	32,8	0,0127	0,0166	0,21	1 360	1 453	1 695	1 726	1 135	962	1 516	1 476

[\*] Without exposure to direct solar radiation, we consider the ampacity is about 20% higher



**Um = 550 kV**

Sections mm <sup>2</sup>	Overall diameter mm	Weight (Kg/m)	DC conductor resistance at 20 °C Ω/km	AC apparent conductor resistance at 90 °C	Capacitance μF/km	CONTINUOUS CURRENT RATING, A Earthing at one point				CONTINUOUS CURRENT RATING, A Earthing in several points			
						Direct buried	Pulled in ducts	In air, trefoil Exposed to solar radiation (*)	In air, flat Exposed to solar radiation (*)	Direct buried	Pulled in ducts	In air, trefoil Exposed to solar radiation (*)	In air, flat Exposed to solar radiation (*)
800	124,0	29,5	0,0221	0,0316	0,14	949	977	1 078	1 108	881	797	1 035	1 045
1 000	132,5	33,3	0,0176	0,0234	0,15	1 112	1 179	1 292	1 324	980	853	1 204	1 196
1 200	136,5	36,0	0,0151	0,0203	0,16	1 195	1 271	1 405	1 437	1 034	891	1 295	1 278
1 600	143,0	41,0	0,0113	0,0158	0,17	1 353	1 452	1 624	1 643	1 128	957	1 461	1 426
2 000	150,0	46,0	0,0090	0,0132	0,18	1 481	1 601	1 817	1 842	1 195	1 007	1 599	1 545
2 500	158,0	52,5	0,0072	0,0113	0,19	1 601	1 742	2 010	2 026	1 251	1 053	1 728	1 653



**Um = 550 kV**

Sections mm <sup>2</sup>	Overall diameter mm	Weight (Kg/m)	DC conductor resistance at 20 °C Ω/km	AC apparent conductor resistance at 90 °C	Capacitance μF/km	CONTINUOUS CURRENT RATING, A Earthing at one point				CONTINUOUS CURRENT RATING, A Earthing in several points			
						Direct buried	Pulled in ducts	In air, trefoil Exposed to solar radiation (*)	In air, flat Exposed to solar radiation (*)	Direct buried	Pulled in ducts	In air, trefoil Exposed to solar radiation (*)	In air, flat Exposed to solar radiation (*)
800	124,0	24,4	0,0367	0,0497	0,15	767	782	867	895	729	679	845	860
1 000	132,5	26,8	0,0291	0,0404	0,15	859	903	988	1 017	806	729	955	968
1 200	136,5	28,3	0,0247	0,0353	0,16	925	975	1 075	1 106	860	770	1 034	1 045
1 600	143,0	30,9	0,0186	0,0241	0,17	1 113	1 172	1 322	1 356	977	860	1 229	1 220
2 000	150,0	33,4	0,0149	0,0195	0,18	1 246	1 316	1 518	1 550	1 060	923	1 383	1 359
2 500	158,0	36,1	0,0127	0,0166	0,19	1 341	1 421	1 652	1 682	1 115	963	1 483	1 447

[\*] Without exposure to direct solar radiation, we consider the ampacity is about 20% higher

# COPPER WIRES WITH ALUMINIUM LAMINATED FOIL

**SILEC**  
BRAND

(Specified and tested according to IEC 60840 and IEC 62067)

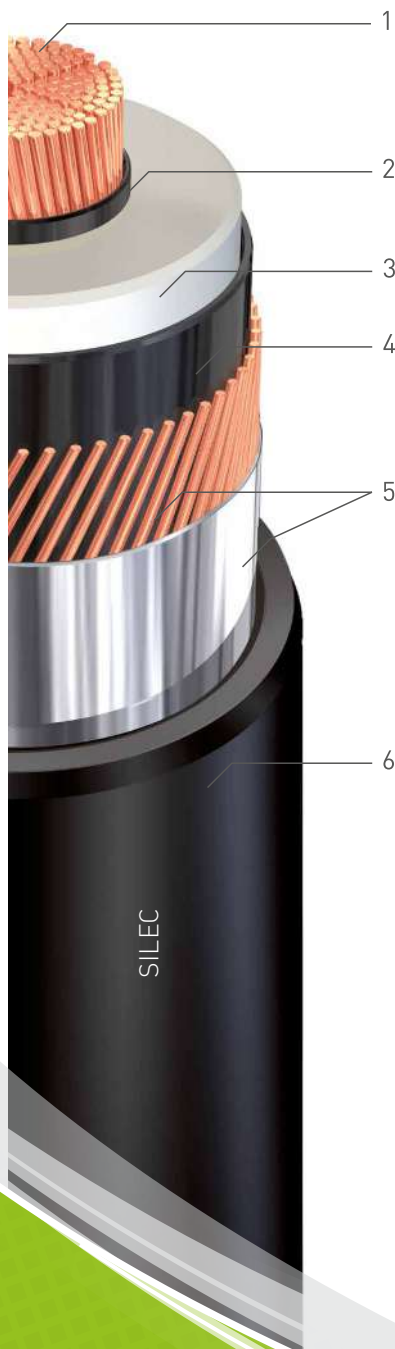

**Range of voltage  $U_m$ : 72,5 kV to 550 kV**

**Range of cross-section: 240 mm<sup>2</sup> to 2 500 mm<sup>2</sup> copper or aluminium**

## CONSTRUCTION:

### 1. CONDUCTOR

Annealed copper - Class 2

Aluminium - Class 2

Concentric conductor  $\leq 1\ 000\ \text{mm}^2$

Milliken or optimized Milliken conductor  $\geq 1\ 200\ \text{mm}^2$

### 2. INNER SEMI-CONDUCTIVE LAYER

Extruded semi-conducting compound

### 3. INSULATION

Cross-Linked Polyethylene [XLPE]

### 4. OUTER SEMI-CONDUCTIVE LAYER

Extruded semi-conducting compound

### 5. SCREEN

Copper wires plus metallic foil bonded to the sheath

### 6. SHEATH

HDPE or halogen-free fire-retardant oversheath

Optional: conductive coating



**Um = 72,5 kV**

Sections mm <sup>2</sup>	Overall diametre mm	Weight (Kg/m)	DC conductor resistance at 20 °C Ω/km	AC apparent conductor resistance at 90 °C	Capacitance µF/km	CONTINUOUS CURRENT RATING, A Earthing at one point				CONTINUOUS CURRENT RATING, A Earthing in several points			
						Direct buried	Pulled in ducts	In air, trefoil Exposed to solar radiation (*)	In air, flat Exposed to solar radiation (*)	Direct buried	Pulled in ducts	In air, trefoil Exposed to solar radiation (*)	In air, flat Exposed to solar radiation (*)
240	54,5	4,9	0,0754	0,0974	0,23	529	547	577	596	513	470	564	577
300	56,5	5,5	0,0601	0,0783	0,25	596	618	660	682	573	515	641	653
400	59,5	6,4	0,0470	0,0622	0,27	676	703	761	786	643	565	733	744
500	64,5	7,6	0,0366	0,0496	0,31	766	801	881	908	718	618	839	846
630	67,9	9,1	0,0283	0,0399	0,34	861	908	1 007	1 036	794	669	947	949
800	72,3	10,8	0,0221	0,0329	0,37	955	1 019	1 141	1 171	865	717	1 056	1 050
1 000	78,8	13,0	0,0176	0,0237	0,42	1 133	1 196	1 394	1 421	961	782	1 223	1 184
1 200	83,2	15,0	0,0151	0,0207	0,45	1 213	1 287	1 513	1 537	1 007	818	1 305	1 254
1 600	89,6	19,1	0,0113	0,0163	0,47	1 363	1 463	1 735	1 748	1 083	874	1 442	1 366
2 000	96,6	23,3	0,0090	0,0137	0,52	1 479	1 602	1 928	1 928	1 131	920	1 548	1 450



**Um = 72.5 kV**

Sections mm <sup>2</sup>	Overall diametre mm	Weight (Kg/m)	DC conductor resistance at 20 °C Ω/km	AC apparent conductor resistance at 90 °C	Capacitance µF/km	CONTINUOUS CURRENT RATING, A Earthing at one point				CONTINUOUS CURRENT RATING, A Earthing in several points			
						Direct buried	Pulled in ducts	In air, trefoil Exposed to solar radiation (*)	In air, flat Exposed to solar radiation (*)	Direct buried	Pulled in ducts	In air, trefoil Exposed to solar radiation (*)	In air, flat Exposed to solar radiation (*)
240	53,5	3,4	0,1250	0,1609	0,23	413	425	451	467	405	386	444	457
300	55,5	3,6	0,1000	0,1290	0,25	466	480	516	534	455	427	507	520
400	58,5	4,0	0,0778	0,1009	0,27	533	550	600	621	516	476	586	600
500	63,5	4,5	0,0605	0,0791	0,31	608	629	697	721	583	527	675	688
630	67	5,1	0,0469	0,0621	0,34	694	720	812	839	658	582	780	790
800	71	5,7	0,0367	0,0497	0,37	783	816	934	963	731	634	886	892
1 000	78	6,5	0,0291	0,0407	0,41	873	916	1 066	1 096	800	683	995	995
1 200	82	7,3	0,0247	0,0356	0,44	937	987	1 158	1 253	848	720	1 053	1 110
1 600	88,5	9,0	0,0186	0,0241	0,47	1 139	1 188	1 441	1 468	959	801	1 258	1 217
2 000	95,5	10,7	0,0149	0,0195	0,53	1 273	1 329	1 655	1 668	1 031	862	1 397	1 328

[\*] Without exposure to direct solar radiation, we consider the ampacity is about 20% higher



Um = 123 kV

Sections mm <sup>2</sup>	Overall diameter mm	Weight (Kg/m)	DC conductor resistance at 20 °C Ω/km	AC apparent conductor resistance at 90 °C	Capacitance µF/km	CONTINUOUS CURRENT RATING, A Earthing at one point				CONTINUOUS CURRENT RATING, A Earthing in several points			
						Direct buried	Pulled in ducts	In air, trefoil Exposed to solar radiation (*)	In air, flat Exposed to solar radiation (*)	Direct buried	Pulled in ducts	In air, trefoil Exposed to solar radiation (*)	In air, flat Exposed to solar radiation (*)
240	67,8	5,9	0,0754	0,0973	0,15	525	538	568	585	508	471	556	567
300	69,0	6,5	0,0601	0,0781	0,17	592	608	649	669	568	517	632	643
400	71,0	7,3	0,0470	0,0619	0,18	672	693	750	772	638	569	723	733
500	74,0	8,4	0,0366	0,0493	0,22	763	791	869	894	713	623	829	836
630	77,3	9,9	0,0283	0,0395	0,24	859	897	995	1 021	790	676	937	938
800	82,9	11,9	0,0221	0,0324	0,25	955	1 004	1 126	1 153	861	729	1 046	1 040
1 000	89,2	14,2	0,0176	0,0236	0,28	1 126	1 177	1 367	1 391	951	797	1 206	1 170
1 200	93,6	16,4	0,0151	0,0206	0,30	1 206	1 265	1 483	1 504	994	831	1 285	1 237
1 600	100,2	20,6	0,0113	0,0162	0,32	1 355	1 491	1 701	1 711	1 067	840	1 420	1 348
2 000	106,6	24,8	0,0090	0,0136	0,35	1 471	1 641	1 893	1 890	1 118	880	1 532	1 439



Um = 123 kV

Sections mm <sup>2</sup>	Overall diameter mm	Weight (Kg/m)	DC conductor resistance at 20 °C Ω/km	AC apparent conductor resistance at 90 °C	Capacitance µF/km	CONTINUOUS CURRENT RATING, A Earthing at one point				CONTINUOUS CURRENT RATING, A Earthing in several points			
						Direct buried	Pulled in ducts	In air, trefoil Exposed to solar radiation (*)	In air, flat Exposed to solar radiation (*)	Direct buried	Pulled in ducts	In air, trefoil Exposed to solar radiation (*)	In air, flat Exposed to solar radiation (*)
240	66,5	4,4	0,1250	0,1609	0,15	410	418	443	458	402	385	437	449
300	68	4,6	0,1000	0,1290	0,17	463	473	507	524	451	426	499	511
400	70	4,9	0,0778	0,1009	0,19	530	542	590	610	512	476	577	590
500	73	5,3	0,0605	0,0791	0,22	605	621	686	709	579	528	666	678
630	76,5	5,9	0,0469	0,0618	0,24	691	711	800	825	653	585	769	779
800	81,5	6,8	0,0367	0,0497	0,25	780	805	917	945	726	640	872	879
1 000	88	7,7	0,0291	0,0407	0,28	871	903	1 047	1 075	796	692	981	981
1 200	92,5	8,7	0,0247	0,0356	0,30	935	972	1 137	1 165	842	728	1 055	1 049
1 600	99	10,5	0,0186	0,0241	0,32	1 130	1 206	1 408	1 431	945	775	1 234	1 196
2 000	105,5	12,2	0,0149	0,0195	0,35	1 262	1 354	1 616	1 632	1 017	828	1 374	1 315

[\*] Without exposure to direct solar radiation, we consider the ampacity is about 20% higher



**Um = 145 kV**

Sections mm <sup>2</sup>	Overall diametre mm	Weight (Kg/m)	DC conductor resistance at 20 °C Ω/km	AC apparent conductor resistance at 90 °C	Capacitance µF/km	CONTINUOUS CURRENT RATING, A Earthing at one point				CONTINUOUS CURRENT RATING, A Earthing in several points			
						Direct buried	Pulled in ducts	In air, trefoil Exposed to solar radiation (*)	In air, flat Exposed to solar radiation (*)	Direct buried	Pulled in ducts	In air, trefoil Exposed to solar radiation (*)	In air, flat Exposed to solar radiation (*)
240	63,2	5,9	0,0754	0,0973	0,17	526	541	572	590	510	471	560	572
300	66,7	6,7	0,0601	0,0782	0,18	593	610	653	674	570	517	635	647
400	69,4	7,5	0,0470	0,0619	0,20	673	695	753	776	639	568	726	736
500	75,7	9,0	0,0366	0,0493	0,22	763	790	870	895	713	624	830	836
630	79,2	10,5	0,0283	0,0395	0,23	861	898	1 001	1 028	790	679	942	943
800	84,5	12,4	0,0221	0,0324	0,25	955	1 002	1 126	1 153	860	730	1 046	1 040
1 000	91,0	14,8	0,0176	0,0236	0,27	1 125	1 174	1 366	1 390	948	799	1 205	1 169
1 200	96,6	17,0	0,0151	0,0206	0,29	1 205	1 260	1 479	1 500	991	837	1 282	1 235
1 600	101,8	21,0	0,0113	0,0161	0,31	1 354	1 487	1 700	1 709	1 065	842	1 420	1 348
2 000	108,6	25,3	0,0090	0,0136	0,33	1 469	1 634	1 886	1 883	1 116	884	1 530	1 438



**Um = 145 kV**

Sections mm <sup>2</sup>	Overall diametre mm	Weight (Kg/m)	DC conductor resistance at 20 °C Ω/km	AC apparent conductor resistance at 90 °C	Capacitance µF/km	CONTINUOUS CURRENT RATING, A Earthing at one point				CONTINUOUS CURRENT RATING, A Earthing in several points			
						Direct buried	Pulled in ducts	In air, trefoil Exposed to solar radiation (*)	In air, flat Exposed to solar radiation (*)	Direct buried	Pulled in ducts	In air, trefoil Exposed to solar radiation (*)	In air, flat Exposed to solar radiation (*)
240	62	4,4	0,1250	0,1609	0,17	411	421	447	462	403	385	441	453
300	65,5	4,8	0,1000	0,1290	0,18	463	474	510	527	452	427	501	514
400	68,5	5,1	0,0778	0,1008	0,20	530	543	593	613	513	476	580	592
500	74,5	5,9	0,0605	0,0789	0,21	605	620	686	708	579	529	666	678
630	78	6,5	0,0469	0,0617	0,23	691	711	800	825	653	585	769	779
800	83,5	7,3	0,0367	0,0497	0,25	780	804	917	944	726	641	872	879
1 000	90	8,3	0,0291	0,0404	0,27	870	901	1 046	1 074	795	693	981	980
1 200	95,5	9,3	0,0247	0,0353	0,28	935	969	1 135	1 162	841	732	1 053	1 047
1 600	100,5	10,9	0,0186	0,0241	0,31	1 129	1 204	1 406	1 429	944	777	1 233	1 195
2 000	107,5	12,7	0,0149	0,0195	0,33	1 259	1 349	1 608	1 624	1 015	831	1 371	1 313

[\*] Without exposure to direct solar radiation, we consider the ampacity is about 20% higher



Um = 170 kV

Sections mm <sup>2</sup>	Overall diameter mm	Weight (Kg/m)	DC conductor resistance at 20 °C Ω/km	AC apparent conductor resistance at 90 °C	Capacitance µF/km	CONTINUOUS CURRENT RATING, A Earthing at one point				CONTINUOUS CURRENT RATING, A Earthing in several points			
						Direct buried	Pulled in ducts	In air, trefoil Exposed to solar radiation (*)	In air, flat Exposed to solar radiation (*)	Direct buried	Pulled in ducts	In air, trefoil Exposed to solar radiation (*)	In air, flat Exposed to solar radiation (*)
300	69,5	7,4	0,0601	0,0781	0,17	593	609	652	673	569	518	635	646
400	73,5	8,5	0,0470	0,0619	0,18	673	692	751	774	638	571	725	735
500	80,0	9,9	0,0366	0,0492	0,20	763	787	867	892	713	627	828	835
630	83,5	11,4	0,0283	0,0393	0,21	859	892	993	1 018	788	682	936	937
800	88,5	13,4	0,0221	0,0323	0,23	955	998	1 123	1 149	858	733	1 044	1 037
1 000	96,5	15,9	0,0176	0,0235	0,25	1 123	1 167	1 357	1 380	943	805	1 199	1 164
1 200	100,5	18,0	0,0151	0,0205	0,26	1 203	1 297	1 473	1 492	987	799	1 278	1 231
1 600	105,5	22,0	0,0113	0,0161	0,29	1 353	1 480	1 694	1 702	1 063	850	1 419	1 349
2 000	113,0	26,2	0,0090	0,0135	0,31	1 468	1 624	1 881	1 876	1 111	891	1 529	1 438
2 500	119,0	31,2	0,0072	0,0117	0,33	1 572	1 761	2 062	2 040	1 150	927	1 626	1 515



Um = 170 kV

Sections mm <sup>2</sup>	Overall diameter mm	Weight (Kg/m)	DC conductor resistance at 20 °C Ω/km	AC apparent conductor resistance at 90 °C	Capacitance µF/km	CONTINUOUS CURRENT RATING, A Earthing at one point				CONTINUOUS CURRENT RATING, A Earthing in several points			
						Direct buried	Pulled in ducts	In air, trefoil Exposed to solar radiation (*)	In air, flat Exposed to solar radiation (*)	Direct buried	Pulled in ducts	In air, trefoil Exposed to solar radiation (*)	In air, flat Exposed to solar radiation (*)
300	68,5	5,5	0,1000	0,1290	0,17	463	473	510	526	452	427	501	514
400	72,5	6,1	0,0778	0,1008	0,18	530	542	591	611	513	477	578	591
500	79,0	6,8	0,0605	0,0789	0,20	605	618	684	706	578	530	664	676
630	82,5	7,4	0,0469	0,0617	0,22	690	707	797	821	652	588	766	776
800	87,5	8,3	0,0367	0,0497	0,23	779	800	914	940	724	643	869	875
1 000	95,5	9,4	0,0291	0,0404	0,24	870	896	1 040	1 067	793	698	976	976
1 200	99,5	10,3	0,0247	0,0353	0,26	943	995	1 130	1 157	839	709	1 050	1 044
1 600	104,5	11,9	0,0186	0,0241	0,28	1 127	1 198	1 399	1 422	942	782	1 230	1 193
2 000	112,0	13,6	0,0149	0,0195	0,31	1 257	1 342	1 601	1 616	1 011	837	1 367	1 310
2 500	118,0	14,8	0,0127	0,0166	0,32	1 345	1 447	1 735	1 740	1 049	860	1 443	1 371

[\*] Without exposure to direct solar radiation, we consider the ampacity is about 20% higher



Um = 245 kV

Sections mm <sup>2</sup>	Overall diameter mm	Weight (Kg/m)	DC conductor resistance at 20 °C Ω/km	AC apparent conductor resistance at 90 °C	Capacitance μF/km	CONTINUOUS CURRENT RATING, A Earthing at one point				CONTINUOUS CURRENT RATING, A Earthing in several points			
						Direct buried	Pulled in ducts	In air, trefoil Exposed to solar radiation (*)	In air, flat Exposed to solar radiation (*)	Direct buried	Pulled in ducts	In air, trefoil Exposed to solar radiation (*)	In air, flat Exposed to solar radiation (*)
400	90,5	10,3	0,0470	0,0617	0,14	667	678	732	752	631	575	708	717
500	91,5	11,2	0,0366	0,0490	0,16	758	775	851	874	706	632	814	821
630	95,5	12,8	0,0283	0,0391	0,17	854	877	973	998	779	688	919	920
800	100,0	14,8	0,0221	0,0320	0,18	950	980	1 101	1 126	852	744	1 027	1 021
1 000	107,0	17,3	0,0176	0,0235	0,20	1 113	1 183	1 326	1 346	932	779	1 178	1 147
1 200	112,0	19,6	0,0151	0,0204	0,21	1 192	1 271	1 437	1 454	975	813	1 257	1 215
1 600	117,5	23,7	0,0113	0,0160	0,22	1 339	1 447	1 652	1 659	1 047	864	1 396	1 332
2 000	124,5	28,1	0,0090	0,0134	0,24	1 456	1 585	1 838	1 832	1 099	910	1 510	1 427
2 500	132,0	33,5	0,0072	0,0115	0,25	1 559	1 805	2 016	1 993	1 137	893	1 609	1 507



Um = 245 kV

Sections mm <sup>2</sup>	Overall diameter mm	Weight (Kg/m)	DC conductor resistance at 20 °C Ω/km	AC apparent conductor resistance at 90 °C	Capacitance μF/km	CONTINUOUS CURRENT RATING, A Earthing at one point				CONTINUOUS CURRENT RATING, A Earthing in several points			
						Direct buried	Pulled in ducts	In air, trefoil Exposed to solar radiation (*)	In air, flat Exposed to solar radiation (*)	Direct buried	Pulled in ducts	In air, trefoil Exposed to solar radiation (*)	In air, flat Exposed to solar radiation (*)
400	89,5	7,9	0,0778	0,1008	0,14	525	531	575	593	507	477	564	575
500	90,5	8,2	0,0605	0,0789	0,16	600	609	670	691	573	531	652	663
630	94,5	8,8	0,0469	0,0617	0,17	686	696	780	802	645	590	750	760
800	99,0	9,7	0,0367	0,0497	0,18	774	787	893	918	717	648	852	858
1 000	106,0	10,9	0,0291	0,0402	0,19	864	908	1 017	1 042	786	682	958	959
1 200	111,0	11,9	0,0247	0,0353	0,21	931	978	1 104	1 129	837	717	1 031	1 027
1 600	116,0	13,6	0,0186	0,0241	0,22	1 115	1 175	1 361	1 381	928	792	1 205	1 173
2 000	123,5	15,5	0,0149	0,0195	0,24	1 243	1 314	1 557	1 571	998	850	1 342	1 292
2 500	131,0	17,1	0,0127	0,0166	0,25	1 329	1 416	1 685	1 690	1 035	880	1 418	1 354

[\*] Without exposure to direct solar radiation, we consider the ampacity is about 20% higher



Um = 362 kV

Sections mm <sup>2</sup>	Overall diameter mm	Weight (Kg/m)	DC conductor resistance at 20 °C Ω/km	AC apparent conductor resistance at 90 °C	Capacitance µF/km	CONTINUOUS CURRENT RATING, A Earthing at one point				CONTINUOUS CURRENT RATING, A Earthing in several points			
						Direct buried	Pulled in ducts	In air, trefoil Exposed to solar radiation (*)	In air, flat Exposed to solar radiation (*)	Direct buried	Pulled in ducts	In air, trefoil Exposed to solar radiation (*)	In air, flat Exposed to solar radiation (*)
630	98,5	15,0	0,0283	0,0390	0,16	848	869	968	992	774	686	915	916
800	103,5	17,0	0,0221	0,0319	0,18	944	1 001	1 097	1 121	845	715	1 023	1 018
1 000	110,0	19,1	0,0176	0,0234	0,19	1 105	1 172	1 321	1 342	923	777	1 174	1 144
1 200	115,0	21,3	0,0151	0,0204	0,20	1 183	1 259	1 431	1 449	966	811	1 253	1 212
1 600	121,0	25,6	0,0113	0,0159	0,22	1 329	1 430	1 644	1 651	1 038	865	1 392	1 329
2 000	128,5	30,0	0,0090	0,0134	0,23	1 442	1 640	1 828	1 822	1 085	858	1 502	1 421
2 500	135,5	35,3	0,0072	0,0114	0,25	1 546	1 785	2 011	1 988	1 125	892	1 606	1 505



Um = 362 kV

Sections mm <sup>2</sup>	Overall diameter mm	Weight (Kg/m)	DC conductor resistance at 20 °C Ω/km	AC apparent conductor resistance at 90 °C	Capacitance µF/km	CONTINUOUS CURRENT RATING, A Earthing at one point				CONTINUOUS CURRENT RATING, A Earthing in several points			
						Direct buried	Pulled in ducts	In air, trefoil Exposed to solar radiation (*)	In air, flat Exposed to solar radiation (*)	Direct buried	Pulled in ducts	In air, trefoil Exposed to solar radiation (*)	In air, flat Exposed to solar radiation (*)
630	97,5	11,02	0,0469	0,0617	0,17	681	690	775	798	641	587	747	757
800	102,5	11,93	0,0367	0,0497	0,18	769	802	889	913	712	630	848	855
1 000	109,0	12,69	0,0291	0,0402	0,19	859	900	1 014	1 039	781	680	955	956
1 200	114,0	13,62	0,0247	0,0353	0,20	922	969	1 101	1 125	827	715	1 028	1 025
1 600	120,0	15,5	0,0186	0,0241	0,21	1 106	1 162	1 353	1 374	920	791	1 200	1 169
2 000	127,5	17,44	0,0149	0,0195	0,23	1 232	1 350	1 547	1 561	987	809	1 334	1 286
2 500	134,0	18,94	0,0127	0,0166	0,24	1 318	1 458	1 679	1 705	1 024	832	1 415	1 369

[\*] Without exposure to direct solar radiation, we consider the ampacity is about 20% higher



**Um = 420 kV**

Sections mm <sup>2</sup>	Overall diameter mm	Weight (Kg/m)	DC conductor resistance at 20 °C Ω/km	AC apparent conductor resistance at 90 °C	Capacitance µF/km	CONTINUOUS CURRENT RATING, A Earthing at one point				CONTINUOUS CURRENT RATING, A Earthing in several points			
						Direct buried	Pulled in ducts	In air, trefoil Exposed to solar radiation (*)	In air, flat Exposed to solar radiation (*)	Direct buried	Pulled in ducts	In air, trefoil Exposed to solar radiation (*)	In air, flat Exposed to solar radiation (*)
800	113,5	17,9	0,0221	0,0317	0,16	938	986	1 079	1 102	839	721	1 010	1 006
1 000	118,5	20,3	0,0176	0,0234	0,17	1 096	1 154	1 298	1 318	914	784	1 160	1 132
1 200	122,0	22,4	0,0151	0,0204	0,18	1 173	1 241	1 410	1 427	955	815	1 238	1 200
1 600	128,0	26,8	0,0113	0,0159	0,19	1 317	1 468	1 620	1 626	1 026	826	1 377	1 318
2 000	135,5	31,2	0,0090	0,0133	0,21	1 430	1 615	1 803	1 797	1 075	865	1 490	1 414
2 500	143,5	36,8	0,0072	0,0113	0,22	1 532	1 752	1 981	1 959	1 113	900	1 592	1 498



**Um = 420 kV**

Sections mm <sup>2</sup>	Overall diameter mm	Weight (Kg/m)	DC conductor resistance at 20 °C Ω/km	AC apparent conductor resistance at 90 °C	Capacitance µF/km	CONTINUOUS CURRENT RATING, A Earthing at one point				CONTINUOUS CURRENT RATING, A Earthing in several points			
						Direct buried	Pulled in ducts	In air, trefoil Exposed to solar radiation (*)	In air, flat Exposed to solar radiation (*)	Direct buried	Pulled in ducts	In air, trefoil Exposed to solar radiation (*)	In air, flat Exposed to solar radiation (*)
630	111,5	12,6	0,0469	0,0617	0,14	676	696	757	778	636	581	731	742
800	112,5	12,9	0,0367	0,0492	0,16	764	791	873	897	707	633	835	842
1 000	117,5	13,9	0,0291	0,0400	0,17	853	887	997	1 021	775	684	942	945
1 200	121,0	14,8	0,0247	0,0350	0,18	916	957	1 085	1 109	821	717	1 016	1 013
1 600	127,0	16,8	0,0186	0,0241	0,19	1 096	1 188	1 332	1 352	910	763	1 185	1 157
2 000	134,5	18,7	0,0149	0,0195	0,20	1 221	1 331	1 523	1 536	977	814	1 320	1 275
2 500	142,0	20,5	0,0127	0,0166	0,21	1 305	1 434	1 650	1 655	1 014	839	1 398	1 341

[\*] Without exposure to direct solar radiation, we consider the ampacity is about 20% higher



Um = 550 kV

Sections mm <sup>2</sup>	Overall diameter mm	Weight (Kg/m)	DC conductor resistance at 20 °C Ω/km	AC apparent conductor resistance at 90 °C	Capacitance µF/km	CONTINUOUS CURRENT RATING, A Earthing at one point				CONTINUOUS CURRENT RATING, A Earthing in several points			
						Direct buried	Pulled in ducts	In air, trefoil Exposed to solar radiation (*)	In air, flat Exposed to solar radiation (*)	Direct buried	Pulled in ducts	In air, trefoil Exposed to solar radiation (*)	In air, flat Exposed to solar radiation (*)
800	121,0	19,1	0,0221	0,0316	0,15	929	970	1 063	1 085	830	722	997	995
1 000	129,5	22,2	0,0176	0,0234	0,15	1 082	1 170	1 270	1 289	900	759	1 140	1 116
1 200	134,0	24,4	0,0151	0,0203	0,16	1 158	1 259	1 378	1 394	941	788	1 185	1 218
1 600	140,0	28,9	0,0113	0,0158	0,17	1 299	1 434	1 584	1 590	1 011	836	1 357	1 305
2 000	147,0	33,4	0,0090	0,0132	0,18	1 410	1 573	1 763	1 757	1 057	874	1 468	1 399
2 500	155,0	39,1	0,0072	0,0113	0,19	1 510	1 703	1 939	1 918	1 094	909	1 571	1 485



Um = 550 kV

Sections mm <sup>2</sup>	Overall diameter mm	Weight (Kg/m)	DC conductor resistance at 20 °C Ω/km	AC apparent conductor resistance at 90 °C	Capacitance µF/km	CONTINUOUS CURRENT RATING, A Earthing at one point				CONTINUOUS CURRENT RATING, A Earthing in several points			
						Direct buried	Pulled in ducts	In air, trefoil Exposed to solar radiation (*)	In air, flat Exposed to solar radiation (*)	Direct buried	Pulled in ducts	In air, trefoil Exposed to solar radiation (*)	In air, flat Exposed to solar radiation (*)
800	120,0	14,1	0,0367	0,0491	0,15	755	778	858	881	699	631	822	830
1 000	128,5	15,8	0,0291	0,0399	0,15	843	898	976	999	766	667	925	929
1 200	133,0	16,8	0,0247	0,0347	0,16	906	969	1 061	1 084	811	699	997	997
1 600	139,0	18,8	0,0186	0,0241	0,17	1 081	1 162	1 299	1 319	896	769	1 163	1 140
2 000	146,0	20,9	0,0149	0,0194	0,18	1 202	1 300	1 485	1 498	960	818	1 295	1 256
2 500	154,0	22,8	0,0127	0,0166	0,19	1 285	1 399	1 609	1 614	996	845	1 374	1 324

[\*] Without exposure to direct solar radiation, we consider the ampacity is about 20% higher

# ACCESSORIES

As part of the fully integrated approach and commitment to providing complete system performance, General Cable offers a wide range of Silec® HV/EHV cable accessories. Vital components of an overall cable system, these accessories are designed, manufactured and precision-controlled to ensure best-in-class performance and longterm service reliability.

## A COMPLETE RANGE OF HIGH-AND EXTRA-HIGH-VOLTAGE CABLE ACCESSORIES

From 72,5 kV to 550 kV to connect cables up to 2 500 mm<sup>2</sup> SILEC® advanced technology in compounding and moulding of silicone, EPDM and resins translates into a complete range of high-performance accessories, from 72,5 kV to 550 kV to connect cables up to 2 500 mm<sup>2</sup> per IEC 60840, IEC 62067, IEEE 48 and IEEE 404.

SILEC® HV/EHV cable accessories are 100% validated through a range of calculation, modelling and testing techniques that enable General Cable to continuously adapt and optimize performance to meet the demands of our customers.



Understanding the need for maximum reliability of this vital part of the complete HV/EHV cable system, General Cable considers the following parameters when designing and recommending a cable accessory:

- >> **Thermo-mechanical and dynamic stress:** when in service, joints and terminations can be highly stressed due to heat-cycling in service. That is why our engineering team is always carefully evaluating what type of materials and installation practices are the most suitable to ensure long-term reliability.
- >> **Water-tightness:** it is well-known that water ingress can cause failures. The durability and ingress protection of our cable accessories are assured with sealed devices that are compliant to IEC 62067 standards. These devices are thoroughly tested in recognized international test laboratories. General Cable ensures the availability and training of highly qualified jointers to secure the reliability of the installed accessories.
- >> **The complete bonding system of joints and terminations is tested and approved according to the recommendations of transmission network operators.**



# HOW TO CHOOSE YOUR ACCESSORIES?

The following questionnaire aims at guiding you in the expression of a need for a cable accessory. To avoid any confusion it is recommended to fill in a questionnaire per type of required accessory.

## A –TYPE OF ACCESSORY

### • Cable joint

Type of specific protection if any:

- Straight joint without bonding to earth
- Straight joint with bonding to earth
- Sectionalized joint with coaxial bonding lead
- Sectionalized joint with 2 single-core bonding leads

### • Outdoor sealing end

Pollution level: \_\_\_\_\_ mm/kV

- Composite insulator
- Porcelain insulator
- Synthetic protection

### • Metal-enclosed termination

- Fluid-filled in a GIS metal enclosure
- Dry-type in a GIS metal enclosure
- In a transformer enclosure

## B –TYPE OF CABLE TO CONNECT

For a joint, if 2 different cables have to be connected, it is recommended to fill in 2 different questionnaires regarding the cables.

### 1. Conductor:

- Aluminium
  - Copper
  - Insulated copper
- Cross section: \_\_\_\_\_ mm<sup>2</sup>  
Nominal diameter over conductor: \_\_\_\_\_ mm

- Circular, stranded
- Circular, solid
- Segmented

Nominal current in service: \_\_\_\_\_ A

Multi-phase short-circuit / duration: \_\_\_\_\_ kA/s

### 2. Insulation

- XLPE
- EPR
- PE
- OTHER

Rated voltage U<sub>0</sub>/U (U<sub>m</sub>): \_\_\_\_\_ / \_\_\_\_\_ (\_\_\_\_\_)kV

Minimum diameter over insulation: \_\_\_\_\_ mm

Maximum diameter over insulation: \_\_\_\_\_ mm

### 3. Insulation screen

- Bonded
- Strippable
- Graphite

Nominal diameter over insulation screen: \_\_\_\_\_ mm

### 4. Metallic screen and moisture barrier

Single-phase short-circuit / duration: \_\_\_\_\_ kA/s

- Copper wires
- Aluminium wires

Number of wires: \_\_\_\_\_

Cross-section: \_\_\_\_\_ mm<sup>2</sup>

Optical fibres in the screen?  Yes  No  
If yes, number of OF tubes \_\_\_\_\_

Aluminium sheath                      Copper sheath  
Lead sheath                              Al-corrugated

Aluminium laminate                  Copper laminate  
Cu-corrugated

Wall thickness: \_\_\_\_\_ mm  
Nominal diameter over moisture barrier: \_\_\_\_\_ mm

### 5. Oversheath

- PE
- PVC

Conductive coating?  Yes  No  
If yes:  Extruded  Graphite

Nominal diameter: \_\_\_\_\_ mm

Date of request: \_\_\_\_ / \_\_\_\_ / \_\_\_\_

Name and contact details of requester:

\_\_\_\_\_

\_\_\_\_\_

\_\_\_\_\_

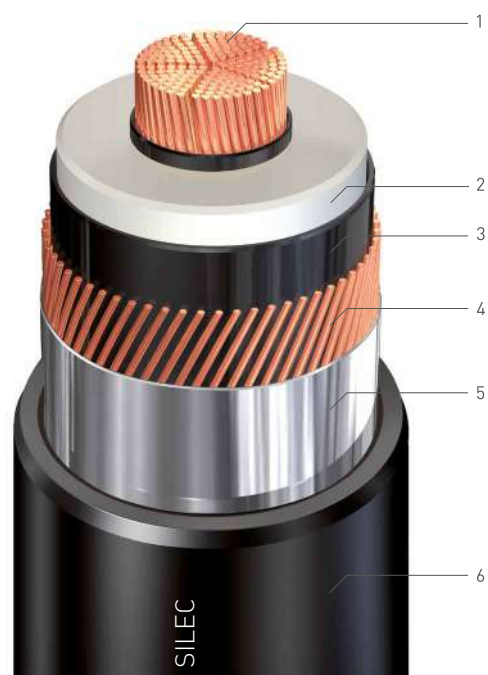

# CODIFICATION

To make it easy to identify what type of cable accessory is needed, you will find below the identification codes to be used for our cable accessories.

How does this work? Follow the steps below to select the accessory:

- >> Identify the type of accessory : Cable joint, metal-enclosed termination, outdoor sealing end
- >> Select type of technology in the according column
- >> Select Maximum rated voltage
- >> Indicate type of screen of the cable to connect
- >> Then select the criteria you are looking for according to the type of accessory you need

**Example:**

I need a **pre-moulded straight joint without earthing**, suitable for a **115 kV (Um = 123 kV)** cable system. The cable has a **wire screen with an aluminium foil laminate**. The splice is protected within a copper casing, and there is a **heat-shrink outer protection** over the casing to insulate it from ground. This cable system does not have an integrated fibre.

## CJ-P-123-WAF-SM-CC-H

	CABLE JOINT (CJ)	OUTDOOR SEALING END (OSE)	METAL-ENCLOSED TERMINATION (MET)	
1. Type of technology	P = pre-moulded joint W = wrapped joint	C = composite P = porcelain S = synthetic protection	R = resin I = directly immersed	
2. Maximum rated voltage		72,5 for Um = 72,5 kV 100 for Um = 100 kV 123 for Um = 123 kV 145 for Um = 145 kV 170 for Um = 170 kV 245 for Um = 245 kV 362 for Um = 362 kV 420 for Um = 420 kV 550 for Um = 550 kV		
3. Type of metallic screen to connect		L = lead sheath WL = wires + lead sheath W = wires AF = aluminium foil WAF = wires + aluminium foil AS = aluminium sheath		
4.a)	<b>Bonding connection</b>			
	SM = straight joint without earthing AM = straight joint with earthing XC = cross-bonding with coaxial lead X2L = cross-bonding with 2 single-core leads			
4.b)		<b>Pollution level</b>		
		P1 = 16 mm/kV P2 = 20 mm/kV P3 = 25 mm/kV P4 = 31 mm/kV P5 = more than 31 mm/kV		
4.c)			<b>Type of interface</b>	
			FF859 = fluid-filled dimension according to IEC 60859 DTB59 = dry-type dimension according to IEC 60859 FF271 = fluid-filled dimension according to IEC 62271-209 DT271 = dry-type dimension according to IEC 62271-209 TWS = transformer T299 = transformer dimension according to EN 50299	



# CODIFICATION

	CABLE JOINT (CJ)	OUTDOOR SEALING END (OSE)	METAL-ENCLOSED TERMINATION (MET)
5. Radial moisture barrier	AT = aluminum tape CC = copper casing		
6. a)	<b>Overprotection of the joint</b> H = heat-shrink sleeves G = coffin box filled with compound IR = injected resin protection		
6. b)		<b>Insulation fluid</b> O = oil G = gas D = dry	
7. Option	OFI = embedded optical fibres internally connected OFE = embedded optical fibres externally connected	OFE = embedded optical fibres externally connected	

# SYNTHETIC OUTDOOR TERMINATION

**SILEC**  
BRAND



Maximum Rated Voltage $U_m$ (kV)	72,5	123
Basic Impulse Level (kV)	325	550
Approximate Height (mm)	1 500	2 000

These slip-on terminations are dry-types and designed for modular assembly. They are based on pre-moulded stress - the number of which is determined by the required creepage distance. These products are designed for operation under severe outdoor conditions.

- >> Range of maximum rated voltage ( $U_m$ ): **72,5 to 123 kV**  
*For 145 kV and above, please contact us.*
- >> Range of cable cross-section: 150 to 1 600 mm<sup>2</sup>
- >> Pollution level: 16 mm/kV to 31 mm/kV

Various connection options for the cable conductor and the metal screen are available according to customer requests. Combined with a relevant supporting structure such as a pillar, it makes a self-supporting dry-type termination. Please contact us for more information.

**OSE-S-xxx-xxx-xx-D-(xxx)**

Maximum Rated Voltage $U_m$ (kV)	72,5	123	145	170	245	362	420	550
Basic Impulse Level (kV)	325	550	650	750	1 050	1 175	1 425	1 550
Approximate Height (mm)	1 900	2 150	2 150	2 400	3 000	4 750	4 750	6 000

These terminations are slip-on and designed for outdoor environments. They are based on pre-moulded stress-control blacks [silicone or EPDM rubber] and composite or porcelain insulators, with the overall length and the shed profile determined by the required creepage distance. These terminations are designed for operation under severe outdoor conditions, including polluted areas.

- >> Range of maximum rated voltage [ $U_m$ ]: **72,5 to 550 kV**
- >> Range of cable cross-section : 150 to 2 500 mm<sup>2</sup>
- >> Pollution Level: 16 mm/kV to 31 mm/kV, or more on demand

Various connection options for the cable conductor and the metal screen are available according to customer requests.

Post-insulators are re-used to electrically insulate the cable screen from the metallic frame.



**OSE-P-xxx-xxx-xx-0 or G-(xx)**

**OSE-C-xxx-xxx-xx-0 or G-(xx)**

# TERMINATION FOR METAL ENCLOSURE (GIS)

Maximum Rated Voltage Um (kV)	72,5	123	145	170	245	362	420	550
Basic Impulse Level (kV)	325	550	650	750	1 050	1 175	1 425	1 550
Overall Height (mm)	1 200	1 400	1 400	1 400	1 650	2 050	2 050	2 050



These terminations are slip-on and designed to IEC 62271-209 [formerly IEC 60859]. They are based on pre-moulded stress-control blocks (silicone or EPDM rubber) and resin moulded insulators. These products are designed to be used under various service conditions.

- >> Range of maximum rated voltage (Um): **72,5 to 550 kV**
- >> Range of cable cross-section: 150 to 2 500 mm<sup>2</sup>

Various connection options for the cable conductor and the metal screen are available according to customer requests.

Resin insulators enable the electrical separation of the cable's metallic screen from the metal enclosure.

**MET-R or I-xxx-xxx-xxxxx-0 or G or D-(xx)**

# OIL-IMMERSED TERMINATION FOR METAL ENCLOSURE

(TRANSFORMER)

Maximum Rated Voltage $U_m$ (kV)	72,5	123	145	170	245
Basic Impulse Level (kV)	325	550	650	750	1 050
Maximum Height (mm)	1 300	1 450	1 450	1 450	1 750

These terminations are a slip-on type. They are based on pre-moulded stress-control blocks (silicone or EPDM) rubber and resin moulded insulators. These products are designed for used under various service conditions.

- >> Range of maximum rated voltage ( $U_m$ ): **72,5 to 245 kV**  
*For 362 kV and above, please contact us*
- >> Range of cable cross-section: 150 to 2 500 mm<sup>2</sup>

Various connection options for the cable conductor and the metallic screen are available according to customer requests.

Resin insulators enable the insulating of the cable's metallic screen from the metal enclosure.



**MET-R or I-xxx-xxx-xxxxx-0 or D-(xx)**

# TAPED JOINTS

**SILEC**  
BRAND

Maximum Rated Voltage $U_m$ (kV)	72,5	123	145
Basic Impulse Level (kV)	325	550	650
Approximate Length (mm) (*)	2 000	2 000	2 000

(\*) This length varies from one configuration to another and should be checked on a case-by-case basis.

General Cable's taped joints offer a wrapping installation technique that provides excellent flexibility and enables the connection of cables in a variety of configurations, such as reduced spaces, cables of different sizes, cables of different designs, and cables of different insulation types, to mention a few.

>> Range of maximum rated voltage ( $U_m$ ): **72,5 to 145 kV**

>> Range of cable cross-section: 150 to 2 500 mm<sup>2</sup>

Various connection options for the cable conductor and the metal screen are available per customer requests.



**CJ-W-xxx-xxx-xxx-AT or CC-xx-(xxx)**

Maximum Rated Voltage $U_m$ (kV)	72,5	123	145	170	245	362	420	550
Basic Impulse Level (kV)	325	550	650	750	1 050	1 175	1 425	1 550
Approximate Length (mm)	2 000	2 000	2 300	2 400	2 600	3 000	3 000	3 200

These joints are a slip-on type. They are based on a pre-moulded stresscontrol black made of in-house compounds, which offers proven dielectric performance.

- >> Range of maximum rated voltage (  $U_m$  ) : **72,5 to 550 kV**
- >> Range of cable cross-section: 150 to 2 500 mm<sup>2</sup>

General Cable offers pre-moulded joints with or without an earth lead, with a shield-break or whatever type of metal screen bonding is required.

Various connection options for the cable conductor and the metal screen are available per customer requests.

Three types of protection are proposed:

- >> Aluminium foil and heat-shrink sleeves
- >> Copper casing and heat-shrink sleeves
- >> Copper casing, filling compound and coffin box



**CJ-P-xxx-xxx-xxx-AT or CC-xx-(xxx)**

Type of Link Box	Approximate Size (mm x mm)	Bonding
Single-Core Earthing	600 x 350	Single-Core Cable
Three-Core Earthing	600 x 600	Single-Core Cable

As required, specific link boxes can be designed to address specific project requirements.



**CJ-W-xxx-xxx-xxx-AT or CC-xx-(xxx)**

As part of a complete cable system, link boxes are vital for the reliability of the cable system. In relation to the bonding concept, General Cable can design and supply the necessary link boxes that make it possible to:

- >> Access the metallic sheath in order to test the outer protection of the system and Limit transient overvoltage by the insertion of surge voltage limiters inside the boxes.
- >> Transpose metal screens at the joints to enable limitation of circulating currents, and protection against over-voltage by the insertion of Surge Voltage Limiters.

Different types of link boxes are available for compatibility with the earthing concept at each point of the cable link:

- >> Single-core earthing
- >> Three-core earthing
- >> Cross-bonding: 2 sizes are available, depending on the required dielectric strength

# TURNKEY SERVICE

Benefiting from years of experience, General Cable's HV/EHV specialists provide superior turnkey services for new cable projects or the upgrade of existing cable circuits. From system and installation engineering, project management and testing to diagnosis, post-project services and training, General Cable is your best partner to install, test and service your entire cable system.

## System Engineering & Management

Our HV/EHV specialists work to develop cable and circuit design according to your specification. Through our experienced and skilled project managers and technicians, General Cable is able to take your project from system design to installation and termination while providing the management and consulting needed to ensure that your project runs smoothly and efficiently. »

- >> Complete and custom cable system design
- >> Project, safety and environmental management and consulting
- >> On-site installation, termination and coordination



On-Site Testing General Cable performs all types of site testing needed to ensure that your system will perform and operate effectively and efficiently while meeting all required standards.

- >> Cable route visual inspection
- >> Serving test on oversheaths
- >> Investigation of leaks (SF<sub>6</sub>, oil) and system faults and failures
- >> HV-resonant tests and partial discharge measurement
- >> Comprehensive test reports

### Diagnosis & Spare Parts

External events can affect your network and reduce its life expectancy. Ongoing diagnosis and assessment of your network today can help you avoid problems tomorrow. General Cable's highly advanced technical consultants and laboratories in France are well-equipped to investigate materials and components. Our experts put forth their technical knowledge to conduct comprehensive site testing, implement immediate preventive measures, and continually assess and renew your spare parts inventory to maintain ongoing operations.

- >> Problem analysis and solutions
- >> Prompt maintenance and replacement of circuit parts
- >> Preventive technical assessments » Material and component testing
- >> Ongoing spare parts delivery Training General Cable testing & commissioning truck (Spain)

### Training

General Cable's Silec training center provides your maintenance crews with the information they need to ensure a high level of knowledge on all Silec products, joints and terminations.

- >> Customized training sessions
- >> On-site training delivery
- >> Ongoing refreshing of knowledge



General Cable testing & commissioning truck (Spain)

# CUSTOMER SERVICE

With more than 14 000 km of cables, 30 000 terminations and 18 000 splices installed and commissioned since 1962, General Cable is your best customer service partner. Since 2010, the Silec Services Department has met customers' expectations by speeding up implementation and improving the efficiency of our service. Our splicers, who are thoroughly trained in our dedicated on-site training center, have enriched their knowledge on several worldwide projects with a specification in High Voltage and Extra High Voltage (63 kV to 500 kV).

## **Our Expedited Process**

From understanding our customer needs and expectations to providing the support and installation they need, we serve you well. With our highly qualified splicers, our customers are ensured an operational network as quickly as possible. When you need us, our experts will service your needs in less than 48 hours. And with a skilled workforce spread across all five continents, General Cable is able to provide the fastest response, whatever the Location.

For customer service, please send your requests to [silec.solutions@generalcable.es](mailto:silec.solutions@generalcable.es)

## **Skills and Resources**

With the expertise, tools and workforce to deliver the best assessment, General Cable gains complete knowledge of your network to optimize customer service and value.

- >> All services compliant with quality, safety, health and environmental regulations (ISO 9001 and 14001)
- >> Fully-equipped portable testing units a cross three continents
- >> Specific tools to detect and Locate SF6 and oil Leakages, cable damages and optical fibre faults



# MONITORING AND DIAGNOSIS

This is an old dream of cable manufacturer and of grids operators to be able on one hand to diagnosis if a cable in service since several years works well without taking the risk to damage it during tests and on the other hand to detect if something works wrong before reaching a failure and have to handle the consequences of an unexpected outage. This dream is now becoming a reality through the measurement of two main parameters made of temperature and partial discharges.

In the coming years we expect to make available systems to measure other parameters such as current and voltages in link boxes or at single point of cable route, mechanical stresses...

## 1 – TEMPERATURE MONITORING – DTS AND RTTR

Thanks to Detection of Temperature sensing we can monitor during the whole service life of a cable system the temperature of a cable system at any point of the cable route enabling the detection of an unexpected hot spot appearing in service before it evolves towards a breakdown.

Such systems are using optical fibers as sensors. Depending on your preference (sensitivity of the measures or flexibility in the project implementation) we can offer either optical fiber cables embedded in the cable either installation of the optical fiber cables along the cable route fixed to a phase conductor or between 2 cables.

General Cable is one of the only one company which can offer an all dielectric design of optical fiber cables to be embedded in a power cable. This type of design is making the connections of the fibers at power joints or at power terminations easier, faster and less tricky.

Of course, on demand, we can also provide the standard stainless steel tubes.

It is also possible to optimize the use of the assets thanks to the combination of a RTTR (Real Time Temperature Rating) with a DTS. Thanks to a RTTR you know at any moment and at any point of the cable route what is the safety margin you can use to face possible emergency situation needing re-allocation of power on the monitored cable link.

General Cable can offer the design of the implementation of such devices associated with its cable systems and can also provide the DTS and RTTR on a project.

## 2 – PARTIAL DISCHARGE MONITORING

Detection of partial discharge (PD) at low level is another way to identify risky cable links before a breakdown appears. The challenge is to get rid of the random and relatively high amplitude noises we usually face during service operation in a transmission grid.

This is now possible thanks to the SILEC® BlueBox featuring a unique filtering device enabling to detect partial discharge even far below the amplitude of surrounding noise.

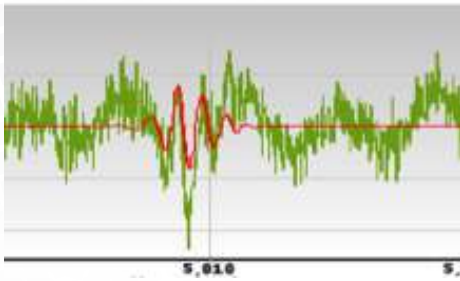

SILEC® BlueBox can be set up along the cable link making possible the monitoring of the whole length of the circuit during the lifetime of the link.

The SILEC® BlueBox is made of 3 main components:

- >> High Frequency Current Transformers (HFCT)
- >> Measuring Systems (MS)
- >> Central Acquisition System (CAS)

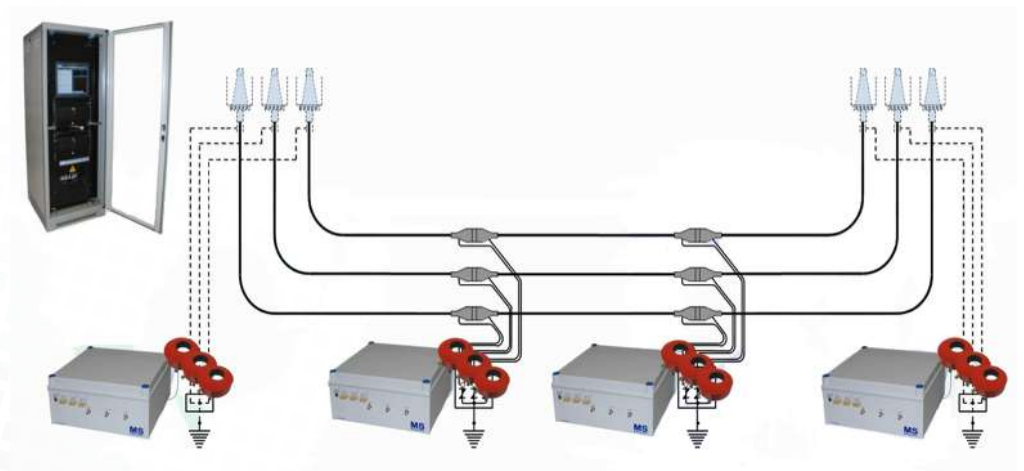

Basically, the HFCT detects, the MS sends a synchronized PD signal to the CAS which captures and process the PD signal.

Thanks to this set-up, you will not only detect appearing PD, automatically localize where it is located and you will cluster the signal so that you can compare to patterns the type of PD and observe PD evolution so that you are able to assess if a planned outage for inspection and up-grading is needed ahead of transition to a breakdown.

This system uses a proven technology which already enabled operators to preserve some of their assets planning operations of inspection and up-grading before facing a breakdown.

As a summary, you can preserve your grids and secure the level of service to your customer thanks to a system based on the following features:

- >> Automatic noise suppression
- >> Automatic PD location
- >> Automatic recognition of the type of defect
- >> Analysis of PD evolution

### **3 – PARTIAL DISCHARGE DIAGNOSIS**

Sometimes, for any reason, a permanent monitoring is not an option in the short term although it is needed to assess the condition of a cable system after some years or decades in service.

Using the mobile version of the Silec® BlueBox, you are able to detect if some PD are present along the circuit at service voltage, thus without taking the risk of leading the cable system to a breakdown during a high voltage test. The diagnosis could be performed by a one shot measurement or it is an option to measure during some weeks, even some months. This operation could be repeated regularly every year, every 2 or several years depending on the cable system conditions, the number of years in service, the service History...

Our aftersales teams with the support of our engineering team will establish the most appropriate maintenance program with you.

# STAND-BY LINKS

General Cable has been providing customers with ready-to-use stand-by links during maintenance or repair operations in numerous applications since the 1970s, offering the continuity of service to maintain end-consumer satisfaction and avoid business losses.

Our Silec® Brand stand-by links are proposed for use during the following situations as they provide service for 60 kV to 220 kV transmission grids; constructed with outdoor sealing ends and/or metal enclosed terminations; easy to handle and set up; reusable after each disconnection; and come with tailored maintenance programs.

- >> Refurbishment and reconstruction of tower and overhead lines Restoration and expansion of high voltage substations
- >> Plant substitutions in high voltage substations

For over 220kV, please contact us.

## 1. DEDICATED DRUM

Each phase is conditioned on dedicated metallic drums fitted out to contain and protect the cable equipped with its two terminations.

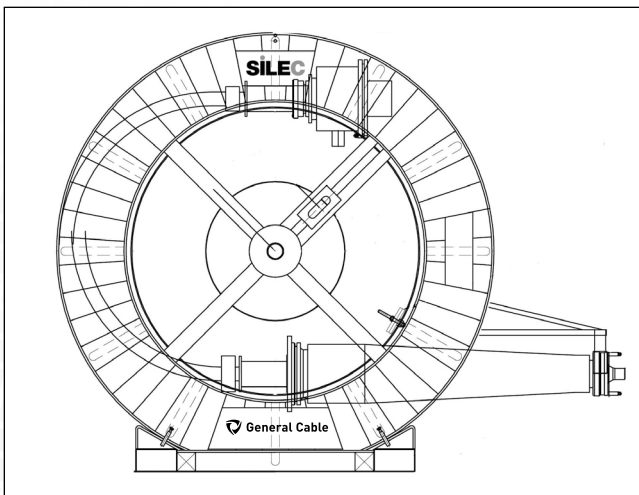

Example of stand-by Links (one outdoor and one GIS termination)



Our ready-to-use stand-by links are typically made of 3 cable lengths fitted with outdoor sealing ends and/or metal enclosed terminations depending on your needs. Metallic gantry to support the terminations and installation components are supplied on demand.

## 2. CABLE

A conductor generally made of aluminium wires

- >> A cross-linked polyethylene insulation (XLPEI)
- >> An aluminium laminate screen stuck to the outer sheath
- >> A thick outer sheath in High Density Polyethylene (HOPE). The cable is designed to get a light and flexible, easy to handle product



## 3. TERMINATIONS (OUTDOOR OR GIS)

To tackle to your needs, we propose different configurations: Dry Type Outdoor Termination, Composite Outdoor Termination or G.I.S. Termination.

## IN-HOUSE ASSEMBLING

The entire stand-by link system is designed, manufactured and equipped in-house to provide ready-to-use equipment. After standard operations of manufacturing and testing, the cable is unreeled on the dedicated stand-by link drum and prepared to receive each termination. The termination is then installed and fixed to the drum for further transportation. Each stand-by link is finally tested in our labs before shipping.

## ON-SITE INSTALLATION

For reconstruction of tower and overhead lines, restoration and expansion in high voltage substations, or plant substitutions in high voltage substations, stand-by links are the solution for maintaining continuity of service on power networks. General Cable can provide you with all accessories needed for the installation of a stand-by link, as well as providing the installation. Though stand-by links are easy to use, we recommend that the first installation is done under the supervision of General Cable's trained staff as there are many advantages to the system that can be conveyed at the time of installation.



Stand-by links in service

## Steps of installation

- >> Set up cable drums (3 phases)
- >> Unreel cable and place terminations for further connection Stand up the terminations on their support
- >> Briefly interrupt power if needed. This step may have to be performed earlier depending on the configuration and safety constraints
- >> Connect terminations
- >> Work quietly on your network Uninstall stand-by Links
- >> Re-condition and store until next maintenance

Our stand-by links can be set-up rapidly making possible the service continuity. They are easy to lay in safe conditions, leading to a reliable connection.

Some of our stand-by links have been in service for more than 60,000 hours combined with many connections and disconnections. After each disconnection, each stand-by link can be re-wound on its reel and is re-usable. Depending on the conditions of storage, installation and service of your stand-by link, General Cable implements a tailored maintenance program.



Typical use of stand-by link far maintenance in substations

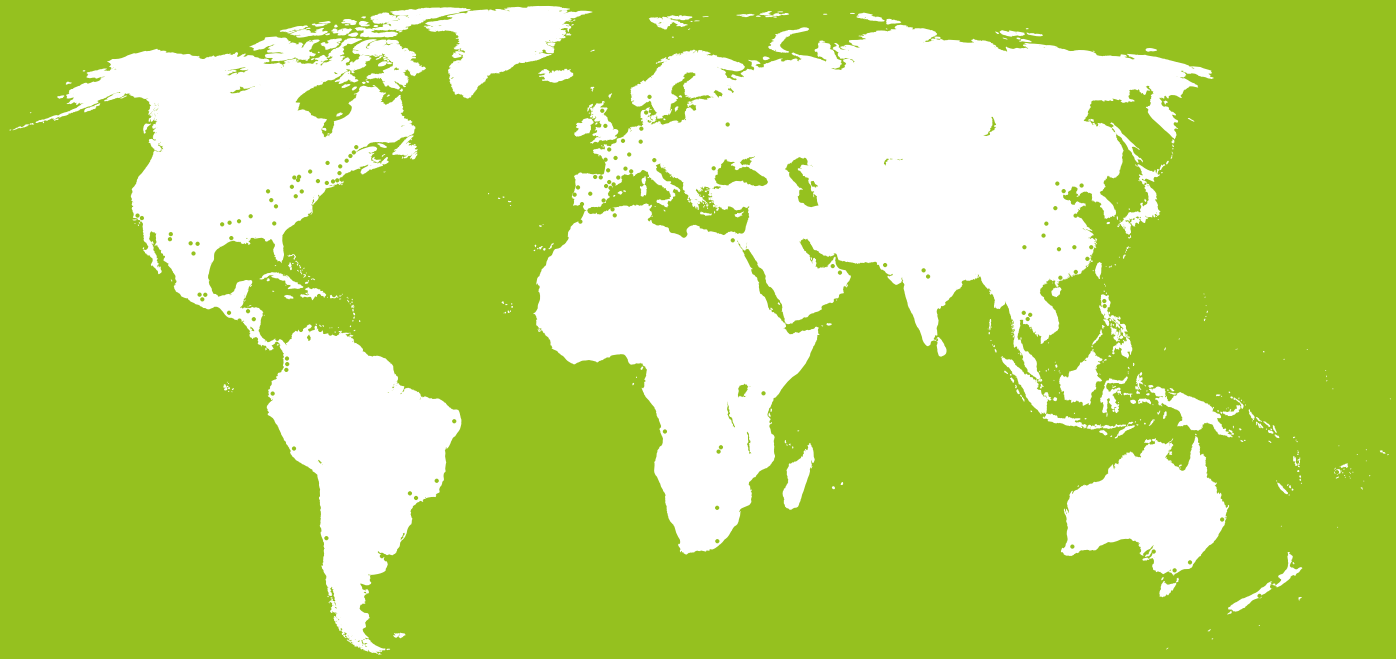

**ARGENTINA**

Tel. : +54 11 4760 6088  
info@generalcable-ar.com

**FRANCE**

Tel. : +33 (0) 160 573 000  
info@generalcable-fr.com

**GERMANY**

Tel. : +49 699 593 24 30  
info@generalcable-de.com

**ITALY**

Tel. : +39 026 604 94 94  
info@generalcable-it.com

**MARROCCO**

Tel. : +212 522 865 300  
info@generalcable-ma.com

**NORWAY**

Tel. : +47 645 59 00  
firmapost@generalcable.no

**POLAND**

Tel. : +48 785 505 652  
info@generalcable-pl.com

**PORTUGAL**

Tel. : +351 219 678 500  
info@generalcable.pt

**ROMANIA**

Tel. : +40 311 011 405  
info@generalcable.ro

**SPAIN**

Tel. : +34 932 279 700  
info@generalcable.es

**UNITED ARAB EMIRATES**

Tel. : +971 264 346 66  
info@generalcable.ae

**UNITED KINGDOM**

Tel. : +44 (0) 7788 243 292  
info@generalcable.co.uk

