

# SOLUTIONS FOR THE ELECTRICAL DISTRIBUTION

## BUSBAR SYSTEM



GLOBAL SPECIALIST IN ELECTRICAL  
AND DIGITAL BUILDING INFRASTRUCTURES

 **legrand**<sup>®</sup>

# LB PLUS

BUSBAR FROM 25, 40 TO 63 A

Light and Power.

The solution that comes from above

page 12

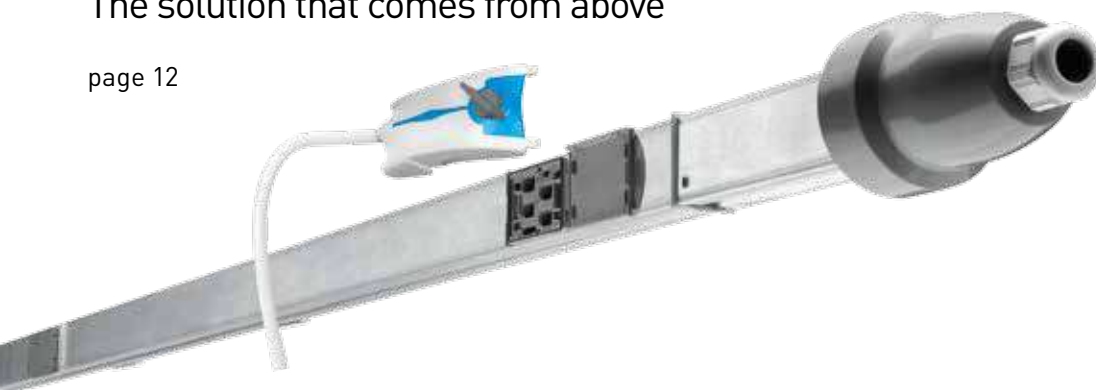

# LB PLUS DATA

BUSBAR FROM 25, 40 TO 63 A

The new busbar trunking system for LIGHTING MANAGEMENT

page 26

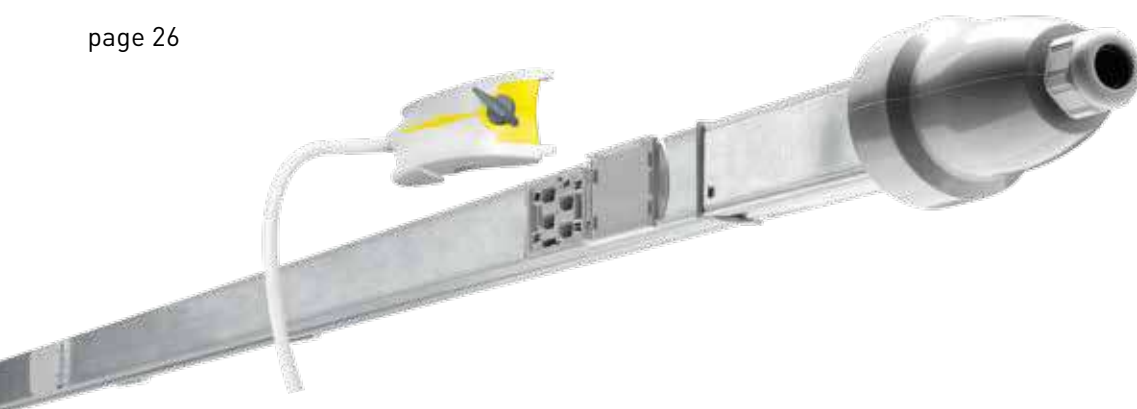

# MINISBARRE (MS)

BUSBAR FROM 63, 100 AND 160 A

The compact solution for medium power distribution

page 32



# MEDIUM RATING (MR)

BUSBAR FROM 160 TO 1000 A

Performance and functionality in medium power

page 42



# TROLLEY SYSTEM (TS-MTS)

BUSBAR FROM 63 TO 250 A

Every time when the power required is on the move

page 74



# SUPER COMPACT (SCP)

BUSBAR FROM 630 TO 6300 A

The power solutions for industrial and service sector applications

page 86



# THE BUSBAR SYSTEM



The busbar is the most modern solution for the distribution of energy in an installation for machinery, equipment and lighting fittings, in all types of buildings such as warehouses, trade fairs.

The busbar is also frequently used to power the (horizontal and vertical) backbones of buildings used for the commercial-service sectors, thus observing the time required for the installation and providing a final solution with remarkable technical advantages.

**Legrand's busbars, available in 3 segmented ranges** (Low Power, Medium Power and High Power), are able to meet all installation requirements, from 25 A to over 6300 A.



## Easy

The electric design of the busbars is achieved in compliance with the product Standards.

The rated current of our busbars is guaranteed at a room average temperature of 40 °C (n.d.r. the Standard requires 35°C).

After choosing the busbar which is able to meet the operating current regulations, it will be very easy to verify the voltage drop as well as the protection against overcurrents by using the technical tables available for all our production lines.

In particular, these tables define a wide range of technical data which allow the planning engineer to carry out calculations with electric values, which are not estimated but the result of measurements made during heating and short circuit tests (in certified LOVAG laboratories), which have certified all product lines.

When using busbars, the load protection is located very close to the device (decentralized protection); junction boxes can contain protection devices such as thermal magnetic circuit breakers, fuse carriers and motorized switches which allow you to easily and efficaciously manage the system.



## Safety

A busbar does not use large amounts of insulating plastic material and potentially dangerous materials in case of fire.

Furthermore, the plastic materials used for the insulating parts of the busbars are always self-extinguishing (from V0 to V2) and the gas emission is generally very low (Halogen Free). Low electromagnetic emission is another advantage of the busbars as a result, the metal plate casing of the BUSBARS serves as a screen for the electric field (shielded enclosure); the extreme vicinity between the phase conductors also reduces considerably the emission of the magnetic field.

The tests carried out on one of our 2500 A SCP (from 150 to 153 page) busbars at full operating current has shown that the emission of the magnetic field (magnetic induction) is lower than the "target level" of the Decree at a distance of 0.3m, whereas the threshold considered as the "quality target" can be achieved at a distance of only 0.7m from the busbar.

These features make our busbars the unavoidable choice for hospital facilities, data processing centres and wherever it is necessary to supply a large amount of power in the proximity of workplaces and/or sensitive equipments.

# THE BUSBAR ADVANTAGE



Example of lighting and small power distribution



Example of high power distribution

## Flexibility

By using the outlet windows located on the straight elements, the busbars provide high management flexibility, both when planning (electrical engineer) and when installing the system (installer); they are also used for the unavoidable changes required by the electric system to adapt to the varied needs of the end user during the life of plant.

The junction boxes can be inserted and removed from their outlets when the busbar is electrically powered and inserted in another plug outlet, thus avoiding downtime.

The engineering department in charge of designing the busbar does not have to know the exact position of the machinery and of the electric loads that will be installed in the company; the project that will be carried out will be open to changes and variations which will be defined by the end user when operationally using the system.

No more point-point connections but only one power distribution system to which you will always be able to connect to wherever there is a free window.

Because of its flexibility and durability features Legrand's busbar, installed inside a building, allows you to easily change the destination of its intended use of the rooms, thus giving also advantages to those who manage and locate the various parts of the building premises.

**NOTE:** the busbar can be used in DC (direct current). For more details contact Legrand

## Quick installation

The busbar's junction and fixing systems have been designed and created to install busbars easily. In a cable and tray system, the time required to install only the tray is the same used to install a complete system in busbars.



Example of space used by cable tray system

Furthermore, given the same capacity, a power busbar, which generally has aluminium conductors, is much lighter than a system made with (copper) cables: lighter weights require a lower number of supporting frames or, in any case, more simple and inexpensive supporting frames.

That is why the installation time of a busbar is obviously shorter than a similar system made with cables.



Example of Legrand busbar system

## Reduced dimensions

The overall dimensions of the busbars are generally smaller than an equivalent system made with cables, especially when the currents to be carried exceed 1000A and when several cables in parallel are necessary to ensure such capacity.

Other advantages can be achieved when there are changes of direction where the radius of curvature of the cables is minimal and enough to not damage the insulating material; busbars allow you to change directions with 90° angles, thus optimizing the small spaces used in service areas.



Example of more space busy by cable tray distribution

# Company approval CERTIFICATIONS

## The quality management system

Legrand has always considered Quality one of the strategic points of its policy, and therefore implements a strict Quality Management System.

The efficacy of the procedures devised and the level of organisation required for their implementation, have enabled the company to obtain the approval certification of its Quality Management System in accordance with the latest edition of the UNI EN ISO 9001 standard. All company processes, from Marketing to Product Development, Manufacturing, Sale, and Technical Support, contribute to meeting the requirements for obtaining and keeping such Approval Certification. The certifying body used is Bureau Veritas. With its presence in over 140 countries, and over 100 years of experience in approval certification, Bureau Veritas is highly recognised by over 30 accreditation bodies, and is today among the world leaders in the field.



## Accreditation of test room laboratory

The test labs have a fundamental role in ensuring the Company Quality, both in terms of development, and as a complement to the design stage, as well as in ensuring that the product complies with the standards (type tests).

The suitability and reliability of the BTicino/Legrand Test Room is guaranteed by the approvals obtained with ACAE (Associazione per la Certificazione delle Apparecchiature Elettriche ed Elettroniche - Association for the Certification of Electric and Electronic Equipment) in accordance with LOVAG procedures, on the basis of UNI CEI EN ISO/IEC 17025 standard.

The Test Room is where some of the main type tests required for obtaining product approval certification are carried out.

With the support of the BTicino\* test room, and of prestigious international labs, Legrand products undergo:

- overtemperature limits tests;
- dielectric properties tests;
- protection circuit efficiency tests;
- aerial and surface insulation distance tests;
- mechanical operation tests;
- busbar trunking system electric characteristics tests;
- construction strength tests;
- thermal cycling test;
- crushing resistance tests.

Moreover, in order to ensure maximum product quality, and in addition to the requirements of the product approval certification, BTicino\* Test Room also carries out electromagnetic compatibility measurements on all lines.

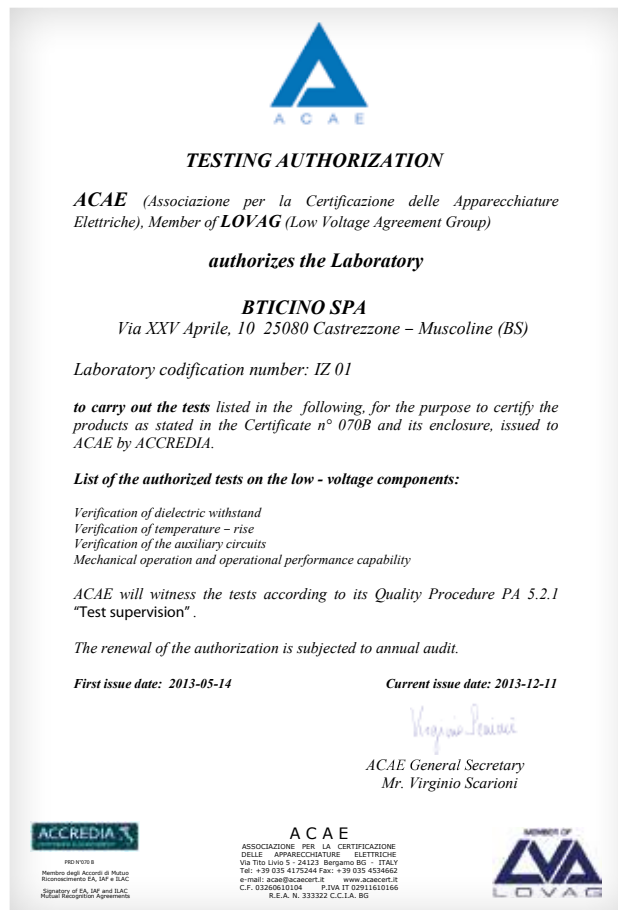

## Mark certifications and approvals

Once compliance with IEC 61439-6 product standard has been confirmed, the various product lines may be further marked and approved for special applications.

The compliance of a product to the specific standards can be certified by the manufacturer declaration and the application of the “CE” symbol, or through the concession of a mark by an appointed third party body that ascertains its compliance. In the case of manufacturer declaration, the responsibility for compliance with the standards lies with the manufacturer

itself; If a quality mark is granted by a third party body, this body will only do so subject to the approval of the manufacturer and the prototype, through type tests, and subsequently following tests on the products sold on the market, which must comply with the requirements of the tests carried out on the prototypes themselves. The same range of products can therefore be granted several quality or conformity marks.

## Lovag-ACAE certifications

Among the various certifications obtained by busbars, special attention must be paid to LOVAG-ACAE approval certifications, which are granted by qualified labs, and are valid in all countries all over the world. ACAE (Association for the Certification of Electric and Electronic Equipment) is a body established in Italy in 1991 operating in the sector of compliance to national and European UNI-CEI EN 45011 standards. This body, operating in the field of the approval certification for electric equipment, in conjunction with ASEFA (France) and ALPHA (Germany), has achieved recognition by

LOVAG (Low Voltage Agreement Group), the European certification body. ACAE itself defines which labs may be qualified on the basis of the accreditations obtained, such as SINAL (Sistema Nazionale per l’Accreditamento dei Laboratori – National System for the accreditation of Laboratories), or through regular inspection visits aimed at ensuring the compliance of the labs itself to the reference standards. ACAE approval certification ensures equal opportunities commercialisation in all countries outside Europe where LOVAG is recognised.



# The CERTIFICATES

The Super-Compact line has been given Type- Approval Certifications by the most prestigious Electro-technical agencies:

- Certificate of Compliance with Standard: 61439-6 (ACAE - LOVAG)
- EAC Type-Approval (Russia) In order to obtain these recognitions, the SCP range has undergone the following type tests, as confirmation of their quality:
- EI 120 fire resistance with Fire Barrier
- IEC 60331-1 / CEI EN 50362 - Fire Resisting Test



# System CONCEPT

Group synergy allows for immediate integration between busbar trunking systems, cast resin transformers and Legrand XL<sup>3</sup> cabinets.

Cast resin transformers can be made to order with a pre-installed interface connection for the busbar trunking systems.

The cabinets XL<sup>3</sup> can be fitted by the factory with a SCP standard board connection.

Thanks to a reinforcement kit it is possible to quickly and easily install any kind of board connection to the roof of the cabinet.

The safety and the performance of the Legrand system are guaranteed by the system approval certification, obtained following stringent tests carried out in the most important international labs.



LIGHTING BUSBARS

CABLE TRAYS

TRUNKING SYSTEMS

AIR  
CIRCUIT  
BREAKERS

LV CABINETS

MOLDED CASE  
CIRCUIT BREAKERS

UPS

MINIATURE  
CIRCUIT  
BREAKERS



# LB PLUS

Light and Power.  
The solution that  
comes from above

## BUSBAR FROM 25, 40 TO 63 A

**LBplus** is the range of busbars for the distribution of energy and lighting from 25 to 63 A. With LBplus, it is possible to have busbars with 10, 16, and 25 A Plugs, with a reduction of the codes of the range, increasing functionality, thanks to accessories suitable for all the versions. With LBplus the line becomes extremely flexible, with the possible to adapt the system to any development.

## Range

**LBplus** has been conceived for the distribution of energy and lighting, all in one product. The main features are:

### 2 PRODUCT SPECIFICATIONS

**LBplus** is available in 2 versions with different profiles, to meet all the installation requirements of the customer. The Type A version (LBA) allows distance between suspension brackets up to 3 metre, while up to 7 metres are possible with the Type B versions (LBB).

### PROTECTION DEGREE IP55

Once the installation of all the accessories has been completed, an IP55 protection degree is ensured. This enables **LBplus** to be used also in particularly demanding situations.

### COMMON ACCESSORIES

All the accessories of the system (feed units, joints) are the same for both types of busbars. This ensure rationalisation of the codes.

### NEW PLUGS

The range of Plugs is extremely complete. Their installation has been made even more simple and immediate, ensuring maximum security for the installer. Plugs up to 25 A with clamp contacts are available.

### CAPTIVE SHUTTERS

The busbars are fitted with captive hinged shutter, which prevents their misplacement during the installation stages.

## Operating flexibility

The construction characteristics of this busbar system make it possible for it to be used in a wide range of solutions, from small/medium service sector applications (offices, hotels, sports establishments, shopping centres), up to industrial dwellings (factories, workshops, production plants, ...)

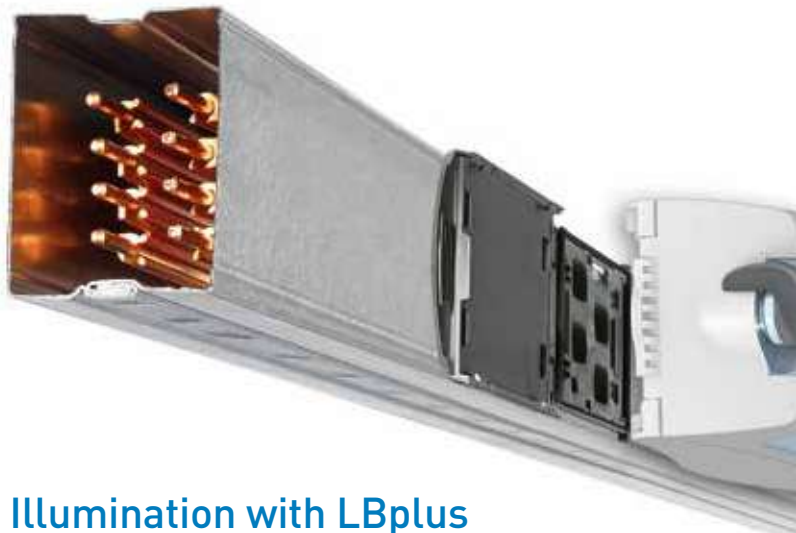

## Illumination with LBplus

The **LBplus** system is suitable for many types of room lighting lamps. By using the many Plugs available, it is possible to power the lamps or the electric users distributed along the system.



MALL AND SUPERMARKETS



OFFICES



WAREHOUSES



HOSPITALS



### BRACKETS

- Ceiling/wall installation or underfloor with special accessory
- Can be positioned anywhere on straight length, even over unused tap-off outlets

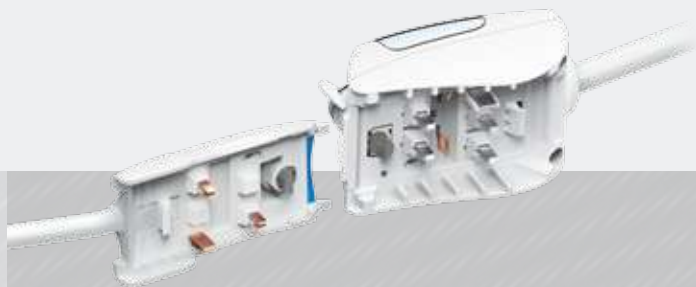

### NEW TAP-OFF PLUGS

- Can be moved when the bar is energised
- With spring clamp contacts
- Self-extinguishing plastic components
- IP55 without using additional accessories
- Can be fitted with positioning pin to ensure tap-off can only access the correct side of a double-sided bar

# SIMPLIFIED INSTALLATION FOR INCREASED PERFORMANCE

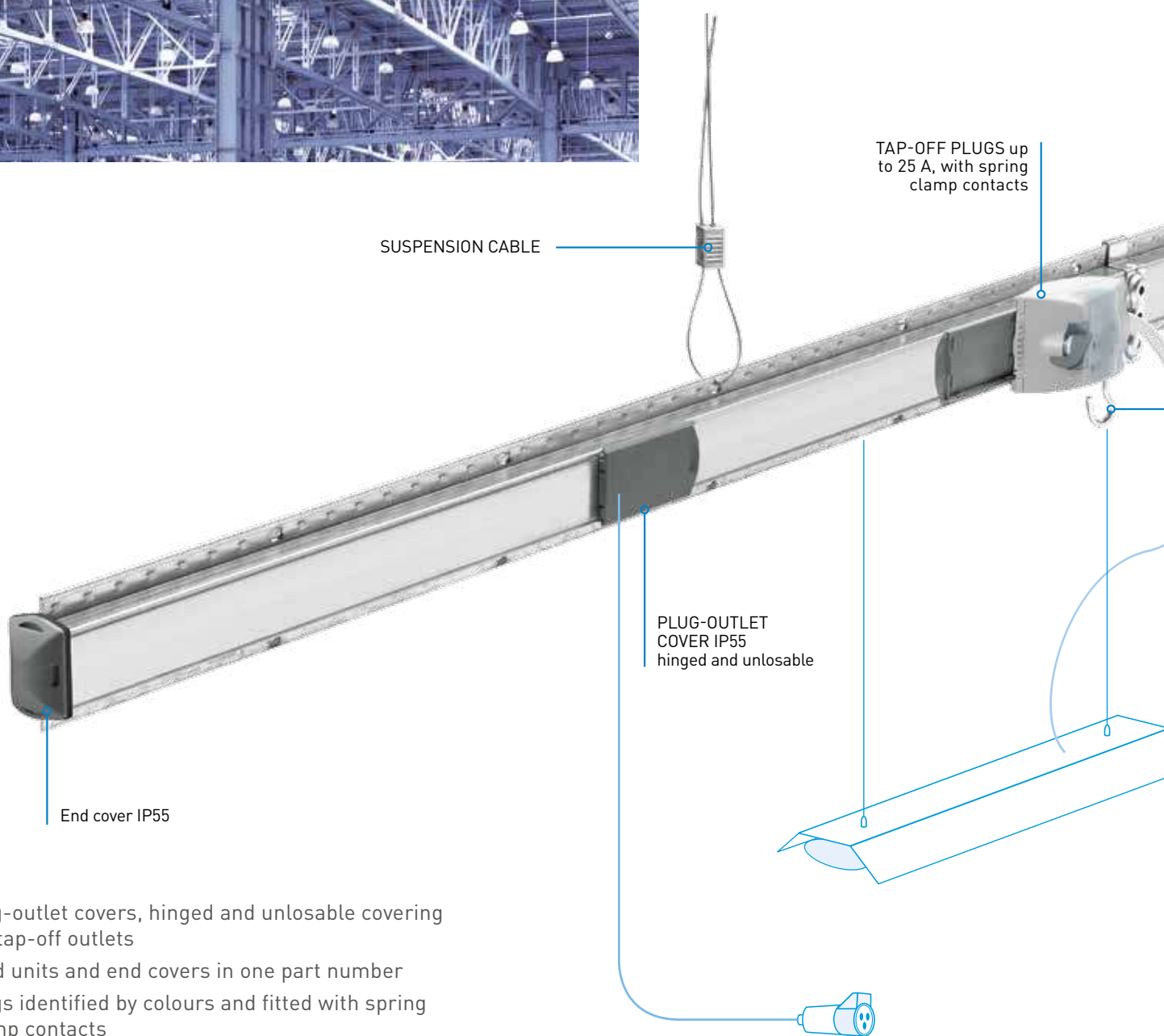

- Plug-outlet covers, hinged and unlosable covering the tap-off outlets
- Feed units and end covers in one part number
- Plugs identified by colours and fitted with spring clamp contacts
- Fool proof plug installation with positioning pin
- Degree of impact-resistance IK 07
- Degree of protection IP55

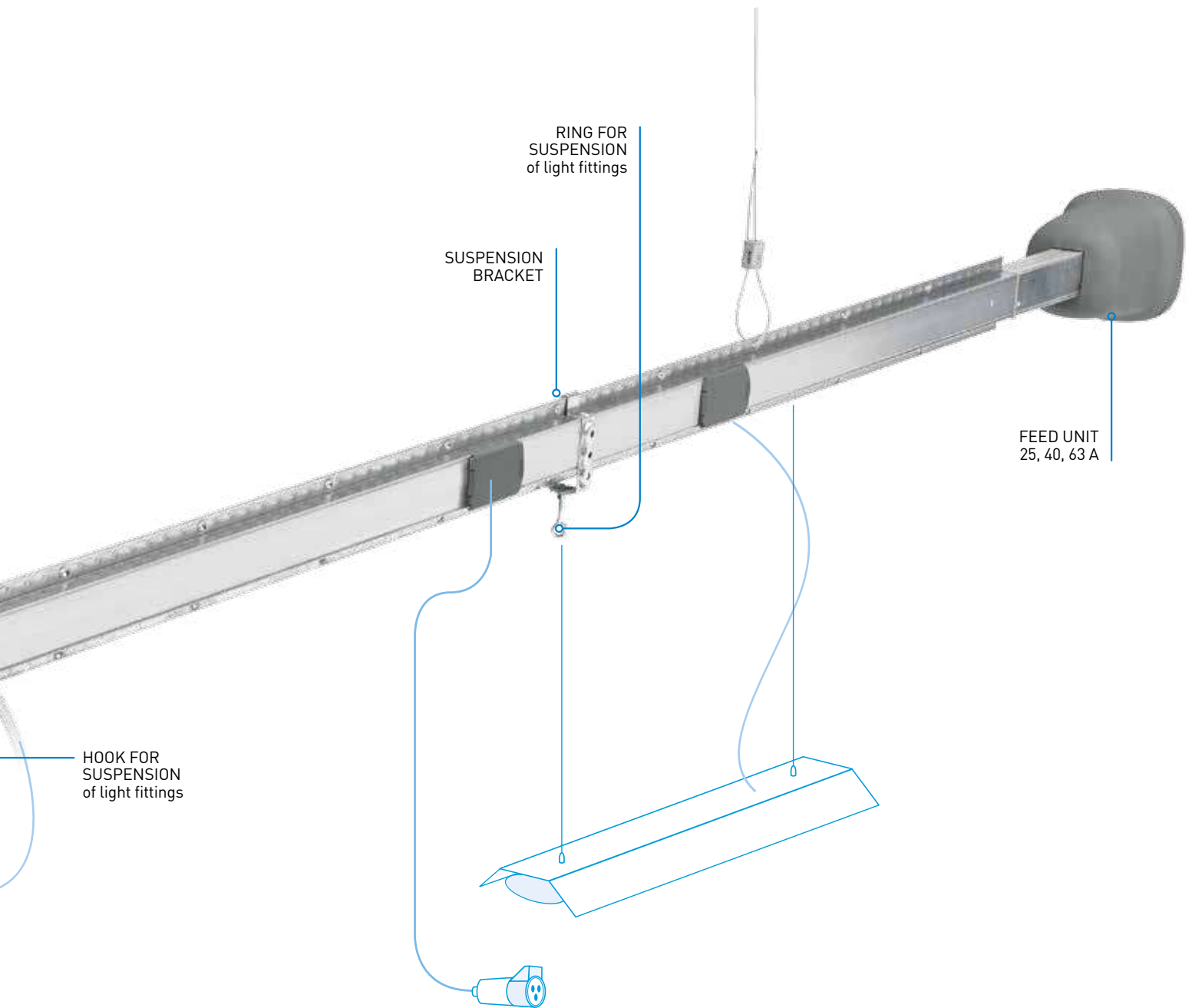

		252	254 - 404	256	258 - 408	634
	LBplus	2 conductors 25A	4 conductors 25-40A	6 conductors 25A	8 conductors 25-40A	4 conductors 63A
TYPE A						
TYPE B						

# LBplus

In= 25-40-63A



Pack	Cat.Nos	Straight elements type A (LBA)					
		Type	In (A)	Lenght (m)	Conductors	Outlets	Weight (kg)
6	75150101	LBA252	25	3	2	2	3.0
6	75160101	LBA254			4	2	3.1
6	75160102	LBA254			4	4	3.2
6	75170101	LBA256			6	2+2	3.7
6	75180101	LBA256			6	2+2	3.8
6	75180102	LBA258	8	4+4	3.9		
6	75200101	LBA404	40	3	4	2	3.6
6	75200102				4	4	3.7
2	75200111				4	2	2.0
6	75220101	LBA408	40	3	8	2+2	4.7
6	75220102				8	4+4	4.8
2	75220111				8	1+1	2.5
6	75240101	LBA634	63	3	4	2+2	4.7
6	75240102				4	4+4	4.8
2	75240111				4	1+1	2.5

Pack	Cat.Nos	Straight elements type B (LBB)					
		Type	In (A)	Lenght (m)	Conductors	Outlets	Weight (kg)
2	75350102H	LBB252	25	3	2	4	5.5
2	75360102H	LBB254			4	4	5.6
2	75360103H	LBB254			4	6	5.6
2	75370101H	LBB256			6	4+4	6.1
2	75380101H	LBB256			6	4+4	6.2
2	75380102H	LBB258	8	6+6	6.35		
2	75400102H	LBB404	40	3	4	4	6.0
2	75400103H				4	6	6.1
2	75400111H				4	2	3.2
2	75420101H	LBB408	40	3	8	4+4	7.1
2	75420102H				8	6+6	7.3
2	75420111H				8	1+1	3.7
2	75440101H	LBB634	63	3	4	4+4	7.1
2	75440102H				4	6+6	7.3
2	75440111H				4	1+1	3.7

Finishes: LBplus type A (LBA) available on request in painted version  
 LBplus type B (LBB) available on request in painted or stainless steel version

# LBplus

In= 25-40-63A

### Dimensions

In compliance with standard IEC 61439-6  
 Degree of Protection IP55  
 Impact resistance IK07  
 Rated current In 25-40-63 A  
 Straight lengths material:  
 LB plus - TYPE A Galvanised steel, thickness 0.45 mm  
 LB plus - TYPE B Reinforced galvanised steel, thickness 0.65 mm

#### Type A

**2 Conductors**

**4 Conductors**

**6 Conductors**

**8 Conductors**

#### Type B

**2 Conductors**

**4 Conductors**

**6 Conductors**

**8 Conductors**

S : single  
D: double

	TYPE A (LBA)						TYPE B (LBB)					
	Outlets (on 1 side)			Outlets (on 2 sides)			Outlets (on 1 side)			Outlets (on 2 sides)		
	2	2	4	1+1	2+2	4+4	2	4	6	1+1	4+4	6+6
<b>L</b>	1500	3000	3000	1500	3000	3000	1500	3000	3000	1500	3000	3000
<b>A</b>	255	1155	705	255	1155	705	255	705	255	255	705	255
<b>B</b>	900	1350	450	-	1350	450	900	450	450	-	450	450
<b>C</b>	-	-	900	-	-	900	-	900	450	-	900	450
<b>D</b>	-	-	450	-	-	450	-	450	450	-	450	450
<b>E</b>	-	-	-	-	-	-	-	-	450	-	-	450
<b>F</b>	-	-	-	-	-	-	-	-	450	-	-	450
<b>G</b>	345	495	495	1245	495	495	345	495	495	1245	495	495
<b>H</b>	-	-	-	1145	1295	845	-	-	-	1145	845	395
<b>I</b>	-	-	-	-	1350	450	-	-	-	-	450	450
<b>M</b>	-	-	-	-	-	900	-	-	-	-	900	450
<b>N</b>	-	-	-	-	-	450	-	-	-	-	450	450
<b>O</b>	-	-	-	-	-	-	-	-	-	-	-	450
<b>P</b>	-	-	-	-	-	-	-	-	-	-	-	450
<b>Q</b>	-	-	-	355	355	355	-	-	-	355	355	355
<b>R</b>	41	41	41	47	47	47	41	41	41	47	47	47

Dimensions in mm

# LBplus

In= 25-40-63A

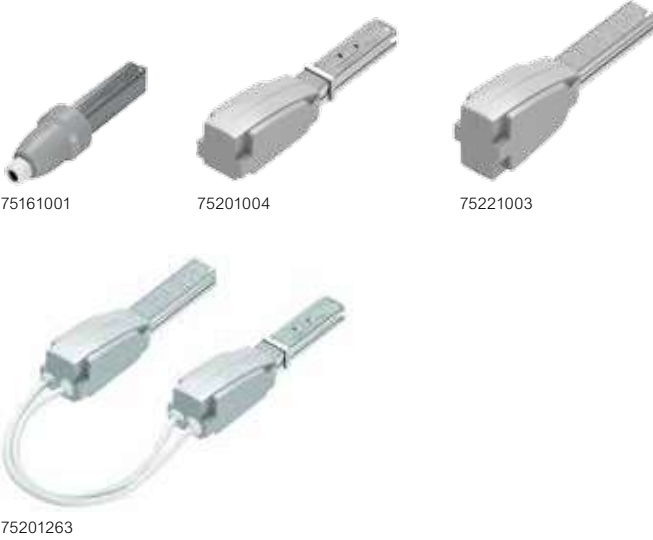

Pack	Cat.Nos	Feed unit	In (A)	Conductors	Description	Weight (kg)
1	75161001	Allows you to electrically power the LBplus line through a cable line. With clamps for connection to rigid or flexible copper cables, and cable terminal. The end feed units include the corresponding end cover. Right feed unit + right end cover. Left feed unit + left end cover. The centre feed unit can be used to power the busbar from an intermediate point of the line, reducing the voltage drop at the end of the line and/or facilitating the installation when the power supply point is near the centre of the line.	25	4	Feed unit RH + end cover RH	0.45
1	75161002				Feed unit LH + end cover LH	0.85
1	75201151*				Intermediate feed unit	3.7
1	75201003		40	4	Reduced feed unit RH+ end cover RH	0.8
1	75201004				Reduced feed unit LH+ end cover LH	1.0
1	75221151*				Intermediate feed unit	4.4
1	75221003		6/8	6/8	Reduced feed unit RH + end cover RH	0.9
1	75221004				Reduced feed unit LH+ end cover LH	1.2
1	75241151*				Intermediate feed unit	2.7
1	75241003		63	4	Reduced Feed unit RH+end cover RH	0.8
1	75241004				Reduced Feed unit LH+end cover LH	1.1
1	75201263				Flexible joint	Weight (kg)
1	75201263	Reduced version 25/40 A at 4 conductors	2.0			
1	75221263	Reduced version 25/40 A at 8 conductors	3.1			
1	75241263	Reduced version 63 A at 4 conductors	2.5			

# LBplus

In= 25-40-63A

### ■ Dimensions

#### Feed unit 254 - Right (RH)

PG21

173

283

Ø 80

CH32

Cable section: max 6 mm<sup>2</sup>  
Cable diameter: min 12 mm  
max 18 mm

#### Feed unit 254 - Left (LH)

110

143

293

80

#### End cover

##### Right

126

2 max

32

40

40

58

##### Left

220

40

2 max

58

#### Reduced feed unit 40/63 A 408

85

115

366

85

#### 404 / 634

85

82

366

85

227

82

227

Cable section: min 6 mm<sup>2</sup>  
Cable diameter: max 25 mm  
max 32 mm

#### Flexible joint 404 / 408 / 634 404/634

85

115

227

940

366

85

82

227

940

366

\* For every intermediate feed unit are included end covers (RH+LH)

## LBplus

### plugs 10 A

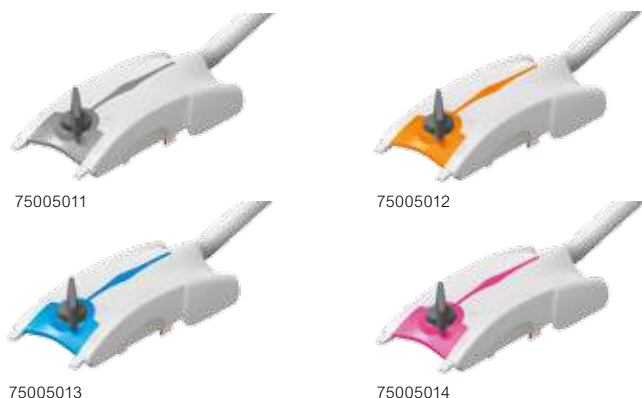

Material Self extinguishing plastic: IEC 60695-2-12 glow wire test and V0 according to UL94. Ratings: In 10-16-25 A.

Pack	Cat.Nos	Single-phase Plugs with fixed phase	Weight (kg)
		<b>Plug 10 A with cable 1 m</b>	
6	75005011	L1-N H05VVF	0.16
6	75005012	L2-N H05VVF	
6	75005013	L3-N H05VVF	
6	75005014	L-N2 H05VVF	
		<b>Plug 10 A with cable 3 m</b>	
4	75005021	L1-N H05VVF	0.38
4	75005022	L2-N H05VVF	
4	75005023	L3-N H05VVF	
4	75005024	L-N2 H05VVF	
		<b>Plug 10 A with cable 1 m</b>	
6	75005061	L1-N FG7OM1	0.2
6	75005062	L2-N FG7OM1	
6	75005063	L3-N FG7OM1	
6	75005064	L-N2 FG7OM1	
		<b>Plug 10 A with cable 3 m</b>	
4	75005071	L1-N FG7OM1	0.48
4	75005072	L2-N FG7OM1	
4	75005073	L3-N FG7OM1	
4	75005074	L-N2 FG7OM1	

## LBplus

### plugs 16 and 25 A



Pack	Cat.Nos	Plugs with selection phase	Weight (kg)
10	75005000	16 A phase selection	0.12
10	75005100	16 A + 1x(5x20 - 6.3 A) fuse included	0.13
2	75005200*	16 A + 1x(CH8)	0.13
2	75005220*	16 A + 1x(CH8) + cable 3m H05VVF	0.64
2	75005270*	16 A + 1x(CH8) + cable 3m FG7OM1	0.68
		<b>Plugs three-phases</b>	
			Weight (kg)
10	75005005	16 A Three-phase Plug	0.13
2	75007005	25 A Three-phase Plug	0.12
2	75007205*	25 A Three-phase Plug with CH8 fuse	0.12
1	75007206*	25 A Three-phase Plug + fuse CH8 + 4 Din box	0.63
1	75007207	25 A Three-phase Plug with 8 Din box	0.80
1	75007006	25 A Three-phase Plug with 4 Din box	0.63
		<b>Accessories</b>	
10	75105000	Mobile contact 16 A	
20	75105001	Kit for the plug coding (it consists of 10 black codes for right side plugs and 10 grey codes for left side plugs and identification stickers). For more details, please look the INSTRUCTION SHEETS	

\* Fuses not included

#### NOTE:

The code 75005000 associated with 2 mobile contacts 75105000 it allows to obtain the three-phase plug 75005005.

# LBplus

plugs 10, 16 and 25 A

## ■ Dimensions

### Plugs 10 A

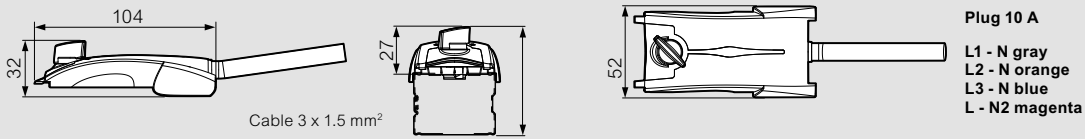

### Example of installation

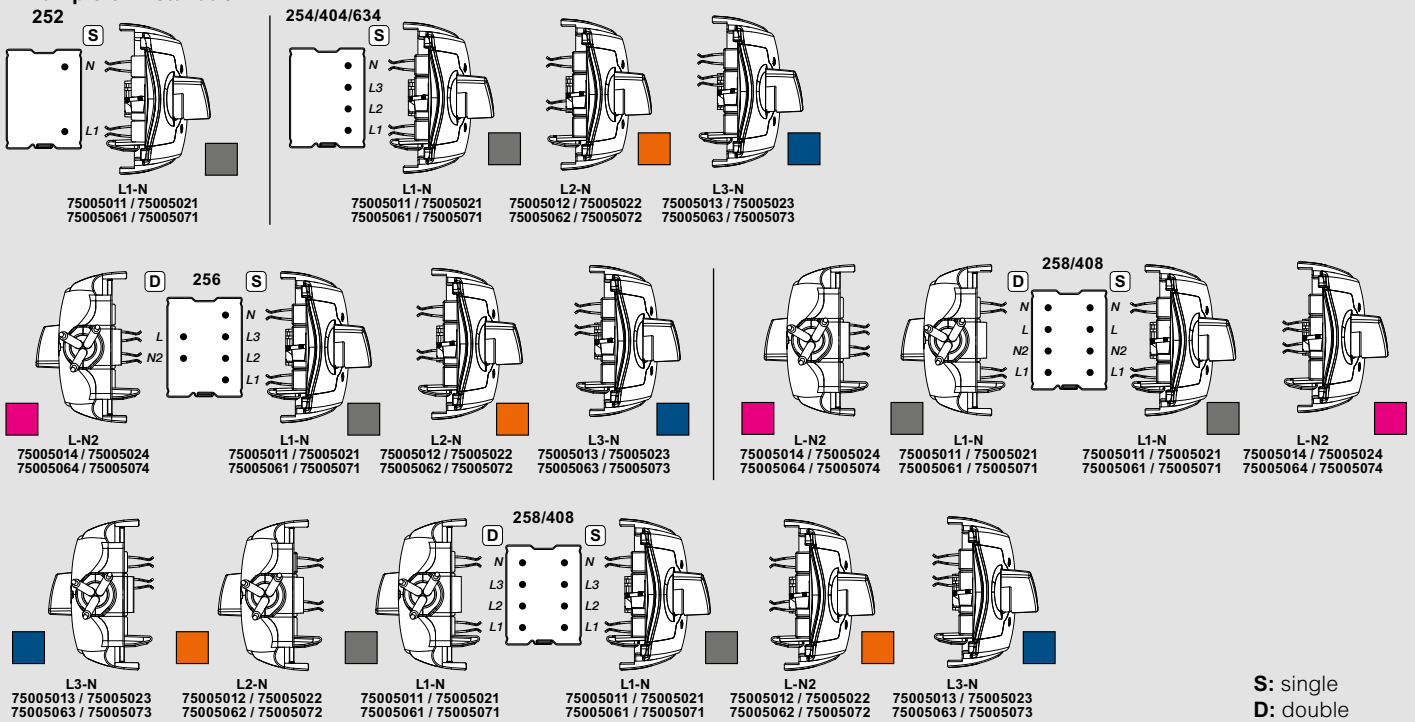

### Plugs 16 A

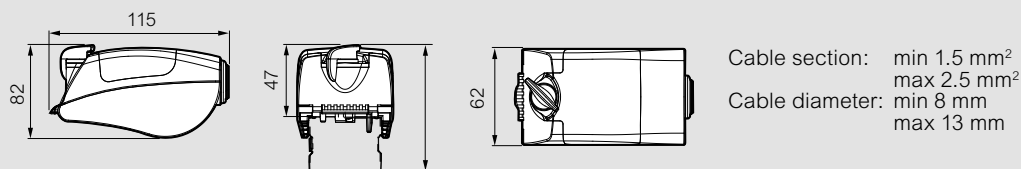

### Plugs 25 A

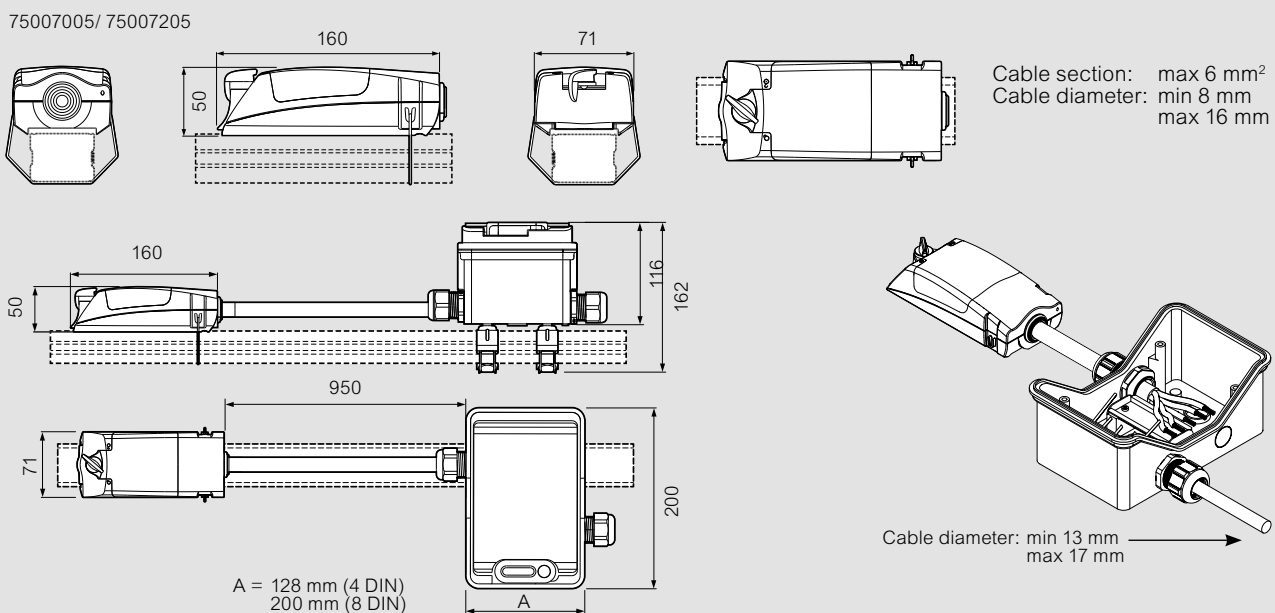

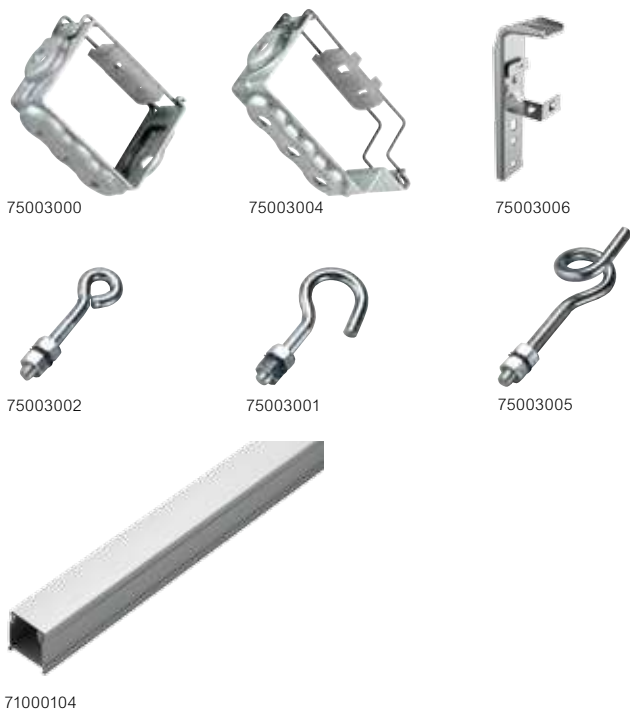

Codes 75003001-2-5 must always be used with brackets 75003000 or 75003004, depending on the TYPE of busbar Item 75003006 must always be used with brackets 75003000 or 75003004 and cable channel 71000104

Bracket 75003000 can be used for the suspension of the line and the suspension of lighting bodies at the same time, while bracket 75003004 may only perform one of the two functions at customer's discretion, depending on its rotation

Pack	Cat.Nos	Brackets	Weight (kg)
12	75003000	60 kg suspension bracket (type A)	0.045
12	75003004	60 kg suspension bracket (type B)	0.045
10	75003001	Hook for lamp	0.015
10	75003002	Ring	0.015
10	75003005	Pigtail for chain	0.015
6	75003006	Bracket for cable channel	0.135
2	75003008	Kit with steel cable (5m) and self locking clamp	0.110
2	75003009	Kit of suspension, bracket (type A), steel cable 3m and self locking clamp	0.130
12	75003007	Spacer on brackets for floor installation	0.040

Pack	Cat.Nos	Accessories	Weight (kg)
10	71000104	PVC cable channel with cover (length 3 m)	0.884
1	755001	Cablofil steel wire cable tray (length 3 m)	1.5

### Fixing supports

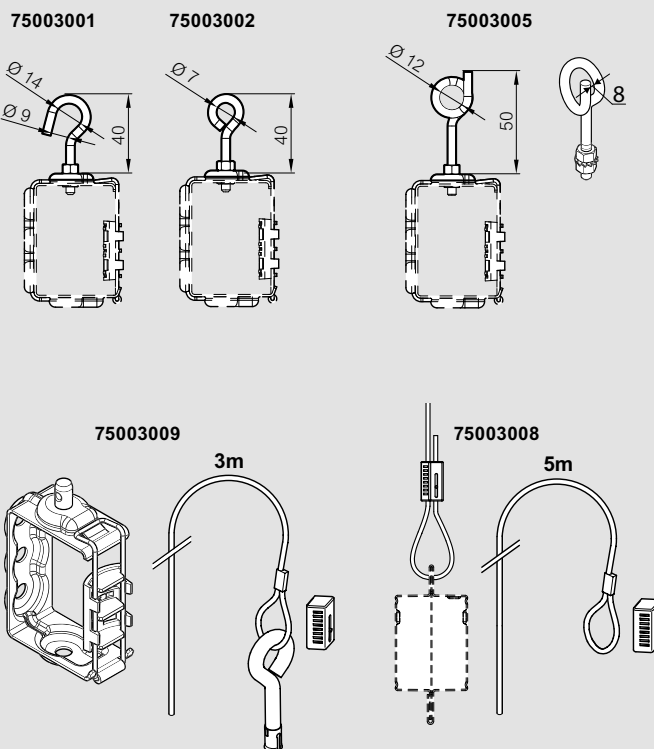

# LBplus

## fixing supports and accessories

### Fixing supports

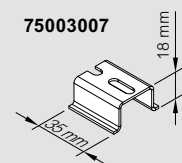
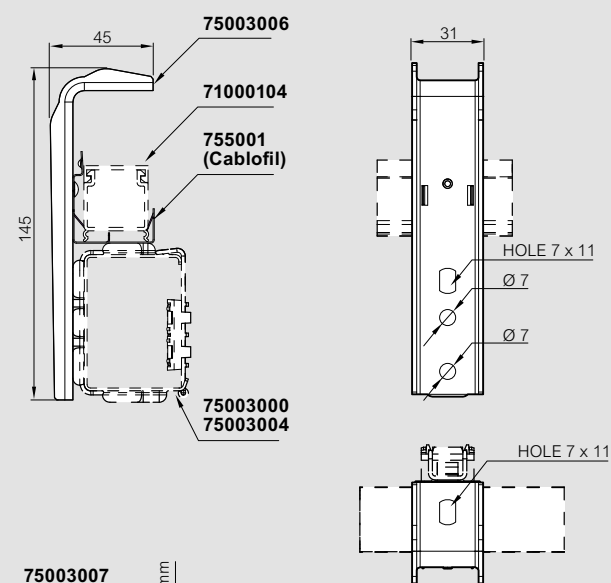
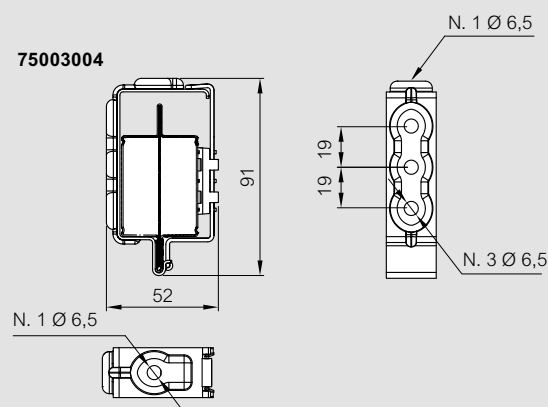
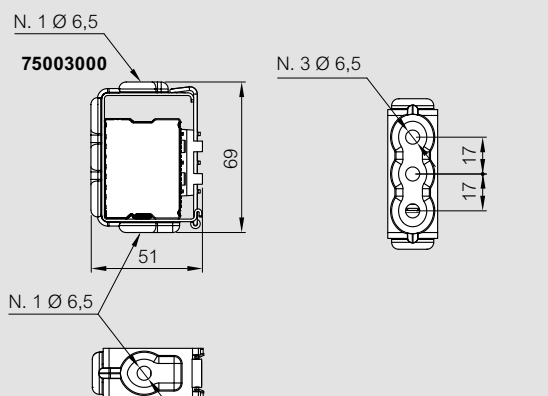

### Accessories

#### PVC cable channel

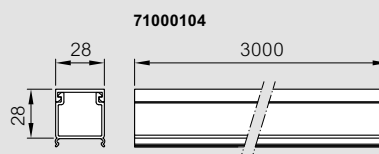

#### Cablofil cable tray

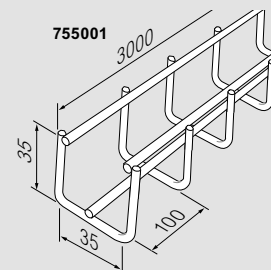

### Technical informations - Choice of the brackets

#### Installation methods

For the suspension of the line and the lighting bodies, the brackets must be fitted with a ranged of appropriate accessories, which must be defined at the moment of the order

#### Ceiling suspension of the line LBplus - Type A (LBA)

##### Pigtail + chain

This solution is possible by ordering suspension bracket item 75003000 and accessory 75003005, preset for the connection of a chain

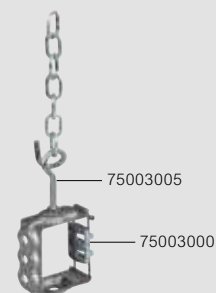

##### Plug + cable bracket

This solution is already supplied as a kit (item 75003009), consisting of a plug bracket, 3 m steel cable and self locking clamp

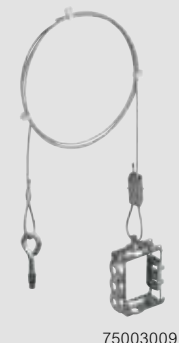

#### LBplus - Type B (LBB)

##### Cable 5 m

This accessory (item 75003008) gives the possibility of suspending the straight element reinforcing busbar using the slots along the reinforcement plate of the straight elements

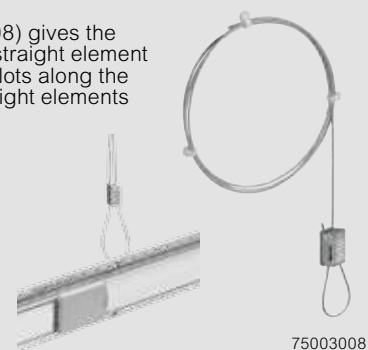

#### Suspension of lighting elements

##### LBplus - Type A and B

For the suspension of lighting elements simply order hooks 75003001 or rings 75003002. These accessories can be installed on the brackets used for the suspension of the ceiling line (item 75003000 and 75003004)



# LBplus

## quick selection table

	252	254	404	256	258	408	634
<b>LB PLUS STRAIGHT LENGTHS - TYPE A</b>							
3m length - 2 and 2+2 outlets	75150101	75160101	75200101	75170101	75180101	75220101	75240101
3m length - 4 and 4+4 outlets	75160102	75160102	75200102	75180102	75180102	75220102	75240102
1.5m length - 2 and 1+1 outlets	75200111	75200111	75200111	75220111	75220111	75220111	75240111
<b>LBplus STRAIGHT LENGTHS - TYPE B</b>							
3m length - 4 and 4+4 outlets	75350102H	75360102H	75400102H	75370101H	75380101H	75420101H	75440101H
3m length - 6 and 6+6 outlets	75360103H	75360103H	75400103H	75380102H	75380102H	75420102H	75440102H
1.5m length - 2 and 1+1 outlets	75400111H	75400111H	75400111H	75420111H	75420111H	75420111H	75440111H
<b>FEED UNITS</b>							
Reduced feed unit RH+ end cover RH	75201003	75201003	75201003	75221003	75221003	75221003	75241003
Reduced feed unit LH+ end cover LH	75201004	75201004	75201004	75221004	75221004	75221004	75241004
Intermediate feed unit	75201151	75201151	75201151	75221151	75221151	75221151	75241151
<b>TRUNKING COMPONENTS</b>							
Reduced flexible joint	75201263	75201263	75201263	75221263	75221263	75221263	75241263
<b>FIXED PHASE SINGLE PHASE TAP-OFF PLUGS (10 A)</b>							
10 A plug with 1 m cable - L1-N H05VVF	75005011	75005011	75005011	75005011	75005011	75005011	75005011
10 A plug with 1 m cable - L2-N H05VVF	-	75005012	75005012	75005012	75005012	75005012	75005012
10 A plug with 1 m cable - L3-N H05VVF	-	75005013	75005013	75005013	75005013	75005013	75005013
10 A plug with 1 m cable - L-N2 H05VVF	-	75005014	75005014	75005014	75005014	75005014	75005014
10 A plug with 3 m cable - L1-N H05VVF	75005021	75005021	75005021	75005021	75005021	75005021	75005021
10 A plug with 3 m cable - L2-N H05VVF	-	75005022	75005022	75005022	75005022	75005022	75005022
10 A plug with 3 m cable - L3-N H05VVF	-	75005023	75005023	75005023	75005023	75005023	75005023
10 A plug with 3 m cable - L-N2 H05VVF	-	75005024	75005024	75005024	75005024	75005024	75005024
10 A plug with 1 m cable - L1-N FG7OM1	75005061	75005061	75005061	75005061	75005061	75005061	75005061
10 A plug with 1 m cable - L2-N FG7OM1	-	75005062	75005062	75005062	75005062	75005062	75005062
10 A plug with 1 m cable - L3-N FG7OM1	-	75005063	75005063	75005063	75005063	75005063	75005063
10 A plug with 1 m cable - L-N2 FG7OM1	-	75005064	75005064	75005064	75005064	75005064	75005064
10 A plug with 3 m cable - L1-N FG7OM1	75005071	75005071	75005071	75005071	75005071	75005071	75005071
10 A plug with 3 m cable - L2-N FG7OM1	-	75005072	75005072	75005072	75005072	75005072	75005072
10 A plug with 3 m cable - L3-N FG7OM1	-	75005073	75005073	75005073	75005073	75005073	75005073
10 A plug with 3 m cable - L-N2 FG7OM1	-	75005074	75005074	75005074	75005074	75005074	75005074
<b>PHASE SELECTION TAP-OFF PLUGS (16 A)</b>							
16 A plug phase selection	75005000	75005000	75005000	75005000	75005000	75005000	75005000
16 A plug + 1x(5x20 - 6.3A) Fuses included	75005100	75005100	75005100	75005100	75005100	75005100	75005100
16 A plug + 1x(CH8)	75005200	75005200	75005200	75005200	75005200	75005200	75005200
16 A plug + 1x(CH8) + 3 m cable H05VVF*	75005220	75005220	75005220	75005220	75005220	75005220	75005220
16 A plug + 1x(CH8) + 3 m cable FG7OM1*	75005270	75005270	75005270	75005270	75005270	75005270	75005270
<b>THREE-PHASE TAP-OFF PLUGS (16 - 25 A)</b>							
16 A three-phase plugs	-	75005005	75005005	75005005	75005005	75005005	75005005
25 A Three-phase Plug	-	75007005	75007005	75007005	75007005	75007005	75007005
25 A Three-phase Plug with CH8 fuse	-	75007205	75007205	75007205	75007205	75007205	75007205
25 A Three-phase Plug + CH8 fuse + 4 Din box	-	75007206	75007206	75007206	75007206	75007206	75007206
25 A Three-phase Plug with 8 Din box	-	75007207	75007207	75007207	75007207	75007207	75007207
25 A Three-phase Plug with 4 Din box	-	75007006	75007006	75007006	75007006	75007006	75007006

\* Fuses not included

**Note:** RH - Right  
LH - Left

# LBplus

## quick selection table (continued)

	252	254	404	256	258	408	634
<b>BRACKETS</b>							
60 kg suspension bracket (LBplus - TYPE A)	75003000	75003000	75003000	75003000	75003000	75003000	75003000
60 kg suspension bracket (LBplus - TYPE B)	75003004	75003004	75003004	75003004	75003004	75003004	75003004
hook for lamp	75003001	75003001	75003001	75003001	75003001	75003001	75003001
ring	75003002	75003002	75003002	75003002	75003002	75003002	75003002
pigtail for chain	75003005	75003005	75003005	75003005	75003005	75003005	75003005
bracket for cable channel	75003006	75003006	75003006	75003006	75003006	75003006	75003006
5m steel cable with self locking clamp	75003008	75003008	75003008	75003008	75003008	75003008	75003008
bracket with 3 m steel cable	75003009	75003009	75003009	75003009	75003009	75003009	75003009
spacer on brackets for floor installation	75003007	75003007	75003007	75003007	75003007	75003007	75003007
<b>ACCESSORIES</b>							
16 A mobile contact	-	75105000	75105000	75105000	75105000	75105000	75105000
window kit code	-	-	-	75105001	75105001	75105001	75105001
cable channel	71000104	71000104	71000104	71000104	71000104	71000104	71000104

### Mechanical loads permitted table

The table shows the maximum weights (kg) that can be supported, both for concentrated, and distributed loads.

LB PLUS TYPE B	LB PLUS TYPE A	Distance between suspension brackets	Concentrated load	Distributed load
		1,5 m	40 kg	50 kg/m (75 kg)**
2 m	30 kg	30 kg/m (60 kg)**		
3 m	20 kg	13 kg/m (39 kg)**		
5 m	13 kg	5 kg/m (25 kg)**		
7 m	7 kg	2 kg/m (14 kg)**		

\*\*Distributed load total weight

# LBplus

## technical informations/specifications

### General features

LBplus can be used for supplying power to light fittings within the service sector, advanced service sector and in most manufacturing industries and wherever it is necessary to hang very heavy accessories and it can be used for supplying power to three-phase and single-phase devices: industrial refrigerators, lathes, handheld tools, etc

LBplus is extremely fast and simple to install. In addition, its flexibility can be used during the planning stage, during installation and during every day use

LBplus, is subdivided in two lines of product, **Type A** and **Type B**

The IP55 degree of protection makes it suitable for false ceiling and raised floor installations

LBplus, as with all Legrand products, is fully compliant with the **CEI EN 61439-6 Harmonized Standards; specifically, the rated current of the Legrand busbar trunking systems is always rated at the average ambient temperature of 40°C** (nb.: the Standard requires 35°C), thus offering the market suitably oversized products

### Straight lengths

Used for distributing power, suspending and powering light fittings and for supplying low-powered loads

LBplus straight lengths include the following components:

**A closed and ribbed section casing for Type A (thickness 0.45 mm, dimension 35x46 mm), a "beam-type" section bar "I" (septum metal separator for the emergency circuits) for Type B (thickness 0.65 mm, dimension 35.2x77 mm including fins) made of galvanized steel** which also serves as a protective conductor due to its cross-section and electrical continuity

The straight lengths are also available in a painted version with RAL colors (optional) and in Stainless Steel version only for type B

**The conductors are separated from each other by a plastic insulating sheath PVC or Blend PC (Poli Carbonat ) ABS HF (Halogen free) self-extinguishing V0 (according to UL94) and in compliance with the incandescent wire test (thickness 1.6mm) as per EN 60695-2-1 (CEI 50.11)**

A series of tap-off outlets to accept plug-in units are located on the busbar

The series outlets are equipped with unlosable outlet covers, in the phase of not using it maintain closed the outlets ensuring a degree of protection IP55 and in the phase of using of outlets, the outlet covers remain in open position on duct

An electrical joint block for automatically connecting live conductors

The connection between two straight lengths is quick: with only one operation to make both the electrical and mechanical connection and at the same time ensures a degree of protection IP55 without the use of additional accessories

The continuity of the protective conductor (casing) is ensured by tightening the special connection screw

**All the duct has the characteristic of NOT Propagation to the flame, according to this aspect of our Product Standard 61439-6 requires this check by referring to the standard specification IEC 60332-3**

### ■ Feed units + end covers (are supplied together)

These enable the LBplus range to be supplied by cable; the assembly is carried out with a quick joint arrangement as with the straight lengths

#### a) Feed Unit 25A 4 conductors + End Cover

Feed unit is equipped with terminals for connection with copper cables rigid or flexible accessorized with tip lugs or without it, with sections up to 6 mm<sup>2</sup>

The entrance point for the cables is located in the back of feed unit and can accept maximum a cable diameter between 12 mm and 18 mm

#### b) Feed Unit 40 A – 63 A + End Cover

Feed unit is equipped with terminals for connection with copper cables rigid or flexible accessorized with tip lugs or without it, with sections from 6 mm<sup>2</sup> to 25 mm<sup>2</sup>

Inside feed unit there's a small bridge gland cable anti-tearing  
The entrance point for the cables is located in the back of feed unit and can accept maximum a cable diameter till to 32 mm

End covers ensure the IP55 degree of protection at the end of the run. Two versions are supplied, depending on the end feed unit used at the start of the run:

- the right (RH) end feed unit requires the use of a right (RH) end cover
- the left (LH) end feed unit requires a left (LH) end cover

### ■ Fixing supports

In order to fix the run to the structure of the building, directly or with a steel chain, it is necessary to use a set of special components to achieve any type of suspension:

#### • bracket Type A:

allows a mounting of the duct to the ceiling and wall of a building, will be provided together with the spacer, which is to be removed when the bracket is inserted above the outlet

The brackets could be mounted everywhere on the busbar, also in front of an outlet maintaining the IP55 degree of protection of the outlet

#### • bracket Type B:

allows a mounting of the duct to the ceiling and wall of a building, will be provided together with the spacer, which is to be removed when the bracket is inserted above the outlet

The brackets could be mounted everywhere on the busbar, also in front of an outlet maintaining the IP55 degree of protection of the outlet

#### • methods of suspension

1. Suspension with the cable
2. The ring + The hook for light
3. Pigtail for chain
4. The hook

### ■ Trunking components and additional elements

Depending on the different installation requirements, Legrand is able to offer different technical solutions:

- flexible joint:** used for changing direction or to avoid possible obstacles along the busbar run  
They have the same quick joint connection as the straight lengths. Similarly, they give a mechanical connection and an IP55 degree of protection with just one operation. The continuity of the protective conductor, made from the casing of the element itself, is ensured by tightening the special connection screw
- cable channel with cover:** this accessory can be placed over the top of the busbar; it can be used to distribute auxiliary circuits, if any, and it is integral with the busbar using a suspension bracket for cable channel. The channel is 3 m long. Its dimensions are 28x28 mm
- Cable tray (Cablofil):** this accessory is positioned in the upper part of the duct, it is useful to distribute auxiliary circuits and is integral with the duct through the use of an accessory for suspension. The cable tray is 3 m long and has dimensions of 35x35 mm
- centre feed unit:** feeds the busbar trunking system from an intermediate point along the run, hence reducing the voltage drop at the end of the line and/or to simplify the installation when the power supply is near the middle of the run

### ■ Plug-in units

These are used for connecting, supplying light fittings and small single-phase and three-phase loads. They include the following features:

- the contacts of the phases are **clamp contacts**
- **they can be operated when energized;**
- the PE contact (protective conductor) is the first to make an electrical connection when plugged into the outlet, and the last to disconnect when unplugged;
- all insulating plastic components are in compliance with the incandescent wire test (EN 60695-2-12) and have a V0 self-extinguishing degree (UL94);
- the standard degree of protection is IP55 without using additional IP protection kits;
- the plugs could be encoded, which means that the plug installed on one side of the busbar cannot be installed on the other side due to a **pin consensus** (sold as accessory) without this one, the plugs can be mounted indistinctly on both side of duct;
- with this simple component, we can have a block for maximum mechanical security

The plug-in units are common for all offer LBplus, these include:

- 10 A fixed phase selection plug-in units**, pre-wired with 1 m, 3 m of FG70M1 and H05VV-F 3 x 1.5 mm<sup>2</sup> cable;
- 16 A phase selection plug-in units – single phase**, with automatic terminals (without bolts) for connecting a L+N+PE cable;
- 16 A phase selection plug-in units – single phase** with a **5x20 and CH8** cylindrical ceramic with automatic terminals (without bolts) for connecting a L+N+PE cable;
- 16 A three-phase plug-in units**, with automatic terminals (without bolts) for connecting a 3L+N+PE cable
- 25 A three-phase plug-in units**, with bolt terminals for connecting a 3L+N+PE cable;
- 25 A three-phase plug-in units**, with the set of three fuse holder cylindrical type CH8, with terminals (with bolts) for connecting a 3L+N+PE cable
- 25 A three-phase plug-in units**, with Box with 4 or 8 DIN

# LBplus

## technical data

			LBPLUS TYPE A (LBA)							LBPLUS TYPE B (LBB)						
			252	254	256	258	404	408	634	252	254	256	258	404	408	634
Number of live conductors			2	4	6	8	4	8	4	2	4	6	8	4	8	4
Overall dimension of the busbars	LxH	[mm]	35 x 46	35 x 46	35 x 46	35 x 46	35 x 46	35 x 46	35 x 46	35 x 77	35 x 77	35 x 77	35 x 77	35 x 77	35 x 77	35 x 77
Rated current	I <sub>n</sub>	[A]	25	25	25	25	40	40	63	25	25	25	25	40	40	63
Operational voltage	U <sub>e</sub>	[V]	400	400	400	400	400	400	400	400	400	400	400	400	400	400
Insulational voltage	U <sub>i</sub>	[V]	500	500	500	500	500	500	500	500	500	500	500	500	500	500
Frequency	f	[Hz]	50/60	50/60	50/60	50/60	50/60	50/60	50/60	50/60	50/60	50/60	50/60	50/60	50/60	50/60
Rated short-time current (0.1 s)	I <sub>cw</sub>	[kArms]	-	2,2	2,2	2,2	2,7	2,7	2,7	-	2,2	2,2	2,2	2,7	2,7	2,7
Peak current	I <sub>pk</sub>	[kA]	-	3,3	3,3	3,3	4,1	4,1	4,1	-	3,3	3,3	3,3	4,1	4,1	4,1
Single phase rated short-time current (0,1 s)	I <sub>cw</sub>	[kArms]	1,3	1,3	1,3	1,3	1,6	1,6	1,6	1,3	1,3	1,3	1,3	1,6	1,6	1,6
Single phase peak current	I <sub>pk</sub>	[kA]	2,0	2,0	2,0	2,0	2,4	2,4	2,4	2,0	2,0	2,0	2,0	2,4	2,4	2,4
Thermal limit	I <sup>2</sup> t	[A <sup>2</sup> s x 10 <sup>6</sup> ]	0,174	0,484	0,484	0,484	0,729	0,729	0,729	0,174	0,484	0,484	0,484	0,729	0,729	0,729
Phase resistance at 20 °C	R <sub>20</sub>	[mΩ/m]	4,761	4,761	4,761	4,761	3,190	3,190	1,595	4,761	4,761	4,761	4,761	3,190	3,190	1,595
Phase resistance at thermal conditions	R <sub>t</sub>	[mΩ/m]	5,656	5,656	5,656	5,656	3,802	3,802	1,901	5,656	5,656	5,656	5,656	3,802	3,802	1,901
Phase reactance at 50 Hz	X	[mΩ/m]	0,229	0,229	0,229	0,229	0,236	0,236	0,118	0,229	0,229	0,229	0,229	0,236	0,236	0,118
Phase impedance	Z	[mΩ/m]	4,767	4,767	4,767	4,767	3,199	3,199	1,599	4,767	4,767	4,767	4,767	3,199	3,199	1,599
Resistance of protective conductor (sheet)	R <sub>PE</sub>	[mΩ/m]	1,695	1,695	1,695	1,695	1,695	1,695	1,695	1,195	1,195	1,195	1,195	1,195	1,195	1,195
Reactance of the protective bar at 50 Hz	X <sub>PE</sub>	[mΩ/m]	0,222	0,222	0,222	0,222	0,222	0,222	0,222	0,274	0,274	0,274	0,274	0,274	0,274	0,274
Resistance of the fault loop	R <sub>o</sub>	[mΩ/m]	6,456	6,456	6,456	6,456	4,885	4,885	3,290	5,956	5,956	5,956	5,956	4,385	4,385	2,790
Reactance of the fault loop	X <sub>o</sub>	[mΩ/m]	0,451	0,451	0,451	0,451	0,458	0,458	0,340	0,503	0,503	0,503	0,503	0,510	0,510	0,392
Impedance of the fault loop	Z <sub>o</sub>	[mΩ/m]	6,472	6,472	6,472	6,472	4,906	4,906	3,308	5,977	5,977	5,977	5,977	4,415	4,415	2,817
Voltage drop with distributed load referred to V3f (**)	ΔV 10 <sup>-3</sup> cosφ = 0,7	[V/m/A]	4,123*	3,570	3,570	3,570	2,830	2,451	1,225	4,123*	3,570	3,570	3,570	2,830	2,451	1,225
	ΔV 10 <sup>-3</sup> cosφ = 0,75	[V/m/A]	4,393*	3,805	3,805	3,805	3,008	2,605	1,302	4,393*	3,805	3,805	3,805	3,008	2,605	1,302
	ΔV 10 <sup>-3</sup> cosφ = 0,8	[V/m/A]	4,662*	4,038	4,038	4,038	3,183	2,757	1,378	4,662*	4,038	4,038	4,038	3,183	2,757	1,378
	ΔV 10 <sup>-3</sup> cosφ = 0,85	[V/m/A]	4,928*	4,268	4,268	4,268	3,356	2,906	1,453	4,928*	4,268	4,268	4,268	3,356	2,906	1,453
	ΔV 10 <sup>-3</sup> cosφ = 0,90	[V/m/A]	5,190*	4,495	4,495	4,495	3,525	3,052	1,526	5,190*	4,495	4,495	4,495	3,525	3,052	1,526
	ΔV 10 <sup>-3</sup> cosφ = 0,95	[V/m/A]	5,445*	4,715	4,715	4,715	3,686	3,192	1,596	5,445*	4,715	4,715	4,715	3,686	3,192	1,596
ΔV 10 <sup>-3</sup> cosφ = 1	[V/m/A]	5,656*	4,898	4,898	4,898	3,802	3,293	1,646	5,656*	4,898	4,898	4,898	3,802	3,293	1,646	
Weight	ρ	[kg/m]	1,00	1,04	1,25	1,28	1,19	1,56	1,56	1,80	1,83	2,02	2,02	1,98	2,33	2,33
Fire load		[kWh/m]	1,0	1,0	1,9	1,9	1,0	1,9	1,9	1,1	1,1	2,1	2,1	1,1	2,1	2,1
Degree of protection	IP		55	55	55	55	55	55	55	55	55	55	55	55	55	55
Degree of impact resistance	IK		07	07	07	07	07	07	07	07	07	07	07	07	07	07
Losses for the Joule effect at nominal current	P	[W/m]	10,6	10,6	10,6	10,6	18,2	18,2	22,6	10,6	10,6	10,6	10,6	18,2	18,2	22,6
Ambient temperature min/MAX	t	[°C]	-5/50	-5/50	-5/50	-5/50	-5/50	-5/50	-5/50	-5/50	-5/50	-5/50	-5/50	-5/50	-5/50	-5/50

(\*) Single phase values with distributed load

**(\*\*) THREE-PHASE:**  $\Delta V_{3f} = \sqrt{3}/2 \times (R_t \cos\phi + X \sin\phi)$   
 $\Delta V_{3f}(In) = I \times L \times \Delta V_{3f}$ : (knowing the current and length of the line)  
 $\Delta V_{3f}(In)\% = (\Delta V_{3f}(In) / U_e) \times 100 (\%)$

To calculate the  $\Delta V_{1f}$  (**SINGLE-PHASE**) on distributed load:

$\Delta V_{1f} = 1/2 \times (2R_t \cos\phi + 2X \sin\phi)$   
 $\Delta V_{1f}(In) = I \times L \times \Delta V_{1f}$ : (knowing the current and length of the line)  
 $\Delta V_{1f}(In)\% = (\Delta V_{1f}(In) / U_e) \times 100 (\%)$

I = operating current (A)

L = length (m)

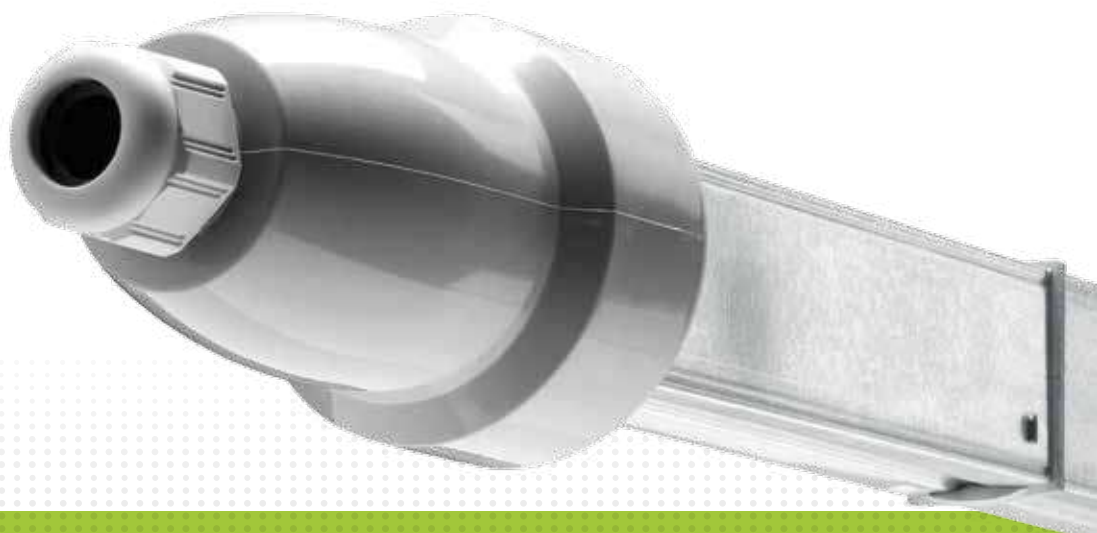

# LBPLUS DATA

## The new busbar trunking system for LIGHTING MANAGEMENT

**LBplus data**, the new busbar conceived for distribution and lighting in the service sector, which integrates a BUS that can be used for Lighting Management.

### Range

**LBplus data** may be used to manage the lighting in the service and industrial sectors, by associating it with BTICINO and LEGRAND LIGHTING MANAGEMENT solutions, and using the DALI and the 1-10 V protocols.

#### ENERGY SAVING

With **LBplus data** there is a reduction of both energy consumption due to artificial illumination (up to 75%, according to UNI EN 15193), and energy waste, thanks to the automatic management of lighting.

#### REDUCTION IN OPERATING COSTS

System maintenance and management costs are significantly reduced, providing an economic return on investments within periods between 6 months and 5 years

#### COMPLIANCE WITH THE STANDARDS

With **LBplus data**, compliance with the EU Directives on energy efficiency both for new and for refurbished buildings is ensured.

#### ENVIRONMENTAL SUSTAINABILITY

With the reduction of energy consumption, there is also an important reduction in the emission of polluting gases in the atmosphere. Renewable energy sources are not the only mean for reaching the environmental sustainability objectives: the starting point is certainly the reduction of existing consumptions.

#### SAME PERFORMANCES AND ACCESSORIES

**LBplus data** has the same electrical and mechanical features of the standard range. It can distribute rated currents from 25 to 63A, and use the same installation accessories of LBplus. The particular characteristic of these new busbars is the presence of two specific conductors, which can be used as lighting management BUSES with LIGHTING MANAGEMENT systems.

#### NEW DEDICATED PLUGS

**LBplus data** has new plugs for drawing energy and for the connection of the BUS. The plugs can be used for the connection of both the various controls, and the lighting bodies for the management of the lighting.

## Maximum flexibility of use

The certified protocols that can be used with LBplus data are the DALI and the 1-10 V protocols.

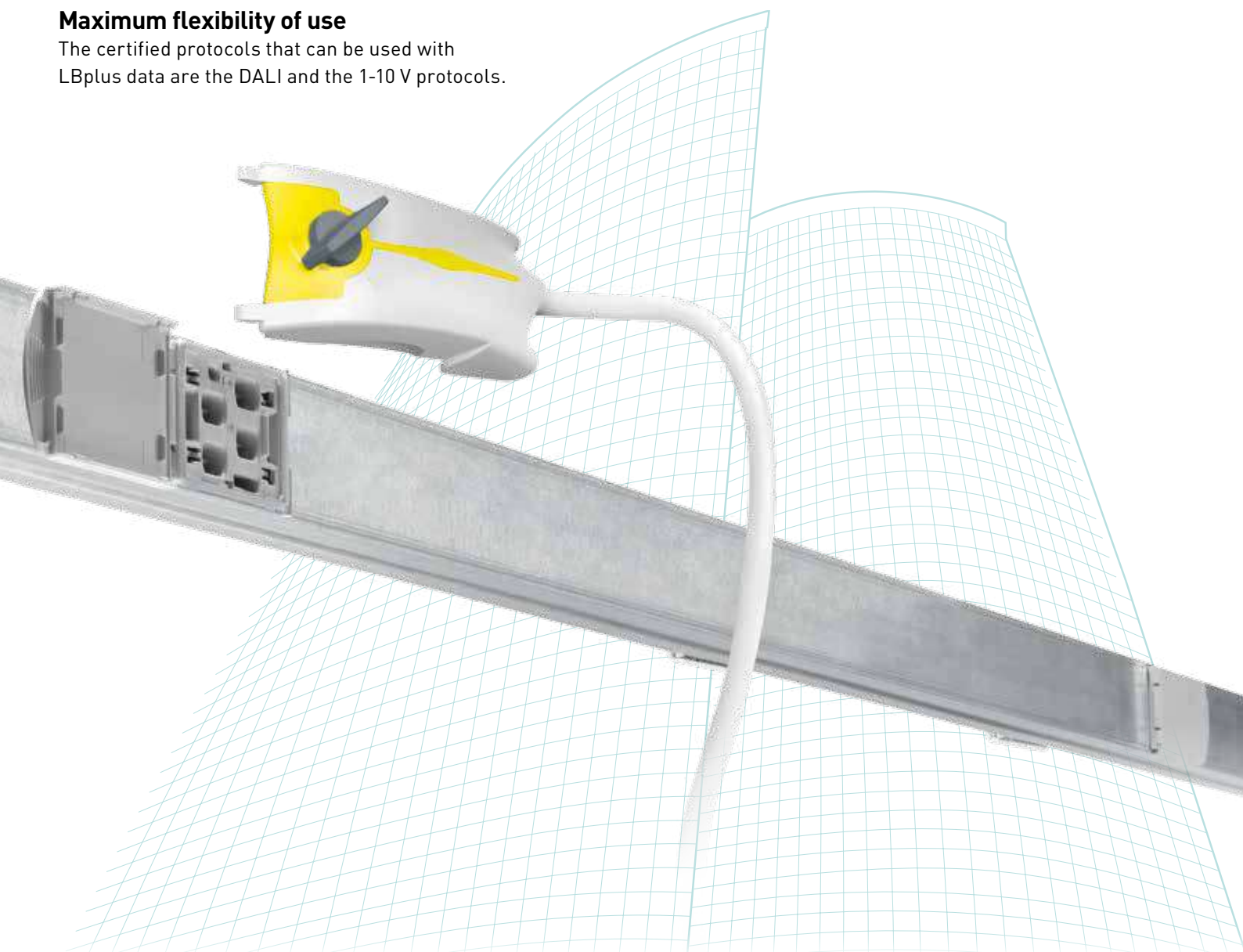

### FULLY ADDRESSABLE DALI

All the lamps are connected to the same output of the DALI gateway and can be managed independently. It is also possible to manage all the lamps in the same way (ON, OFF, dimmed), and create independent sub-groups. The main advantage is the extreme versatility, and the configuration flexibility. This solution is suitable for offices, shopping centres with shops and display areas, supermarket corridors, and in those cases with specific lighting management and reconfiguration flexibility requirements.

### BROADCAST DALI

All the lamps connected to the same DALI interface output are controlled in the same way (ON, OFF, dimmed). This does not allow single ballasts to be managed separately, and wiring groups with simplified configuration may be created. The system feedback functions are, however, maintained. This solution is suitable for installation in warehouses, or systems with corridors that do not need the management of lamp sub-groups or individual ballasts.

### 1-10V

This technology gives the possibility of adjusting lighting devices and dimmers using an analogue voltage signal between 1V, the minimum light level, and 10V, the maximum light level. The switching on and off of the devices is performed by adjusting the feed unit. All the lamps connected to the same 1-10V dimmer output are managed in the same way; it is not possible to have sub-groups, or to manage ballasts independently. This solution is suitable for installation in warehouses, or systems with corridors that do not need the management of lamp sub-groups or individual ballasts.

DALI is a uniform standard shared by the whole lighting sector, which defines a type of interface for digital communication between control modules and electronic feed units. Included in the EN 60929 standards, it ensures interchangeability of electronic feed units from different manufacturers.

For further information on the DALI protocol visit the following website: [www.dali-ag.org](http://www.dali-ag.org)



## LBplus data

In= 25-40-63A

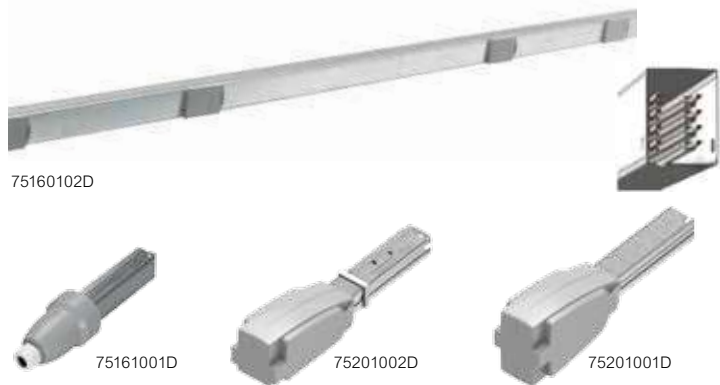

Pack	Cat.Nos	Straight lengths with BUS					
		Type	In (A)	Length (m)	Conductors	Outlets	Weight (kg)
6	75160102D	LBD252	25	3	2	4	3.2
6	75170102D	LBD254			4	4+4	3.2
6	75180102D	LBD256			6	4+4	3.9
6	75200102D	LBD402	40	3	2	4	3.7
2	75200111D			1.5	2	2	2.0
6	75220102D	LBD406	40	3	6	4+4	4.8
2	75220111D			1.5		1+1	2.5
6	75240102D	LBD632	63	3	2	4+2	4.8
2	75240111D			1.5		1+1	2.5

### Feed unit

Allows you to electrically power the LBplus line through a cable line  
 With clamps for connection to rigid or flexible copper cables, and cable terminal  
 The end feed units include the corresponding end cover  
 Right feed unit + right end cover  
 Left feed unit + left end cover  
 The intermediate feed unit can be used to power the busbar from the middle of the line, reducing the voltage drop at the end of the line and/or facilitating the installation when the power supply point is near the centre of the line

		In (A)	Conductors	Description	Weight (kg)
1	75161001D	25	4	RH feed unit + RH end cover	0.45
1	75201001D	40	4	RH feed unit + RH end cover	0.85
1	75201002D			LH feed unit + LH end cover	1.2
1	75201151D	40		Intermediate feed unit*	4.0
1	75221001D	40	8	RH feed unit + RH end cover	0.9
1	75221002D			LH feed unit + LH end cover	1.2
1	75221151D	40		Intermediate feed unit*	4.15
1	75241001D	63	4	RH feed unit + RH end cover	0.9
1	75241002D			LH feed unit + LH end cover	1.2
1	75241151D			Intermediate feed unit*	4.25

**Note:** RH-Right, LH-Left

\*For every intermediate feed unit are included end covers (RH+LH)

Finishes: LBplus data in a painted version is available on request

## LBplus data

In= 25-40-63A

### Dimensions

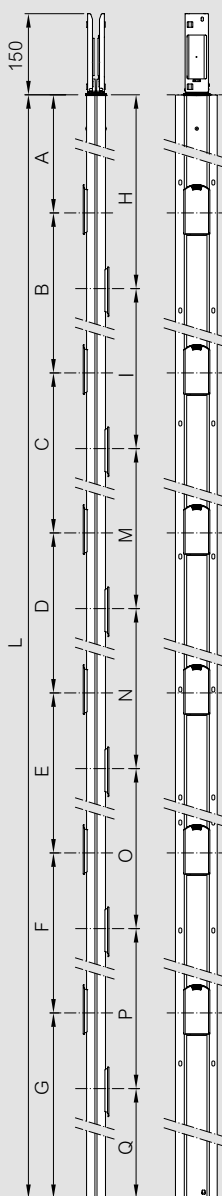

In compliance with standard IEC 61439-6  
 Degree of protection IP55  
 Impact resistance IK07  
 Rated current In 25-40-63 A  
 Straight lengths material:  
 LB plus - TYPE A Galvanised steel, thickness 0.45 mm

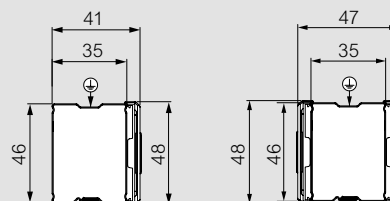

	LBplus data					
	Outlets (on 1 side)			Outlets (on 2 sides)		
	2	2	4	1+1	2+2	4+4
L	1500	3000	3000	1500	3000	3000
A	255	1155	705	255	1155	705
B	900	1350	450	-	1350	450
C	-	-	900	-	-	900
D	-	-	450	-	-	450
E	-	-	-	-	-	-
F	-	-	-	-	-	-
G	345	495	495	1245	495	495
H	-	-	-	1145	1295	845
I	-	-	-	-	1350	450
M	-	-	-	-	-	900
N	-	-	-	-	-	450
O	-	-	-	-	-	-
P	-	-	-	-	-	-
Q	-	-	-	355	355	355

Dimensions in mm

### Feed unit 254

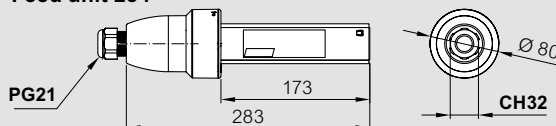

Cable section: max 6 mm<sup>2</sup>  
 Cable diameter: min 12 mm  
 max 18 mm

### Feed unit 404 / 408 / 634

#### 408

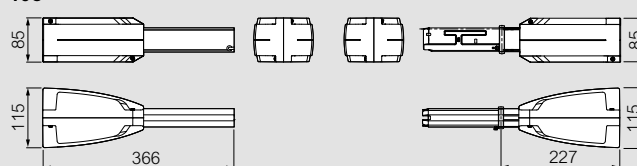

#### 404 / 634

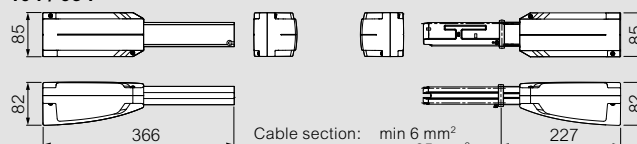

Cable section: min 6 mm<sup>2</sup>  
 max 25 mm<sup>2</sup>  
 Cable diameter: max 32 mm

## LBplus data

In= 25-40-63A (continued)



75221261D



75005014D



75005008D

Material Self extinguishing plastic: IEC 60695-2-12 glow wire test and V0 according to UL94. Loads In 10-16-25 A

Pack	Cat.Nos	Flexible joint	Weight (kg)
1	75201261D	Version 25/40 A at 4 conductors	2.25
1	75221261D	Version 25/40 A at 8 conductors	2.35
1	75241261D	Version 63 A at 4 conductors	2.45
Tap-off plugs with data bus only			
1	75005014D	10 A plug DATA BUS only - cable 1 m D1-D2 H05VVF	0.16
1	75005064D	10 A plug DATA BUS only - cable 1 m D1-D2 FG7OM1	
Power and data tap-off plugs			
1	75005005D	Plug 16 A with BUS DALI - cable 1 m L1-N H05VVF	0.16
1	75005006D	Plug 16 A with BUS DALI - cable 1 m L1-N FG7OM1	
1	75005007D	Kit - Plug 16A with selecting phase (L-N) + plug 10A only DATA BUS, cable 1m 5G1,5 (H05VVF)	0.16
1	75005008D	Kit - Plug 16A with selecting phase (L-N) + plug 10A only DATA BUS, cable 1m 5G1,5 (FG7OM1)	

**Note:** for the choice of other plugs, please see pages 18 and 19. For accessories see pages 20 and 21 (only TYPE A)

## LBplus data

In= 25-40-63A

### Dimensions

#### Flexible joint 404 / 408 / 634

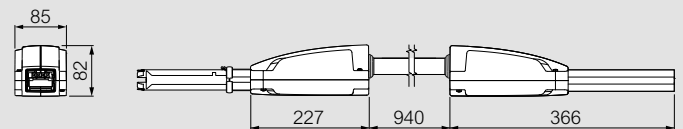
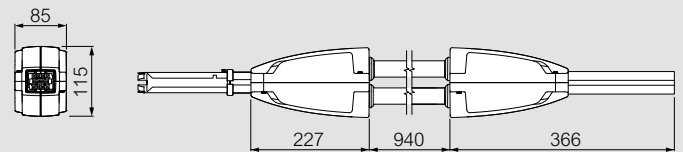

#### Plug 10 A

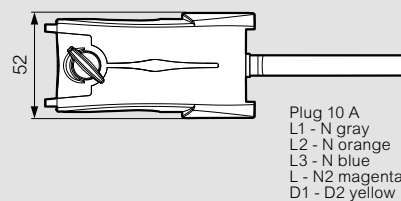
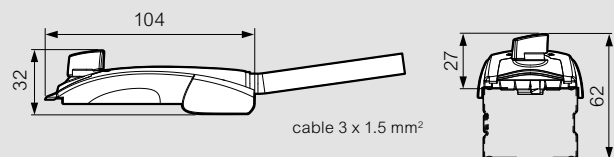

#### Plug 16 A

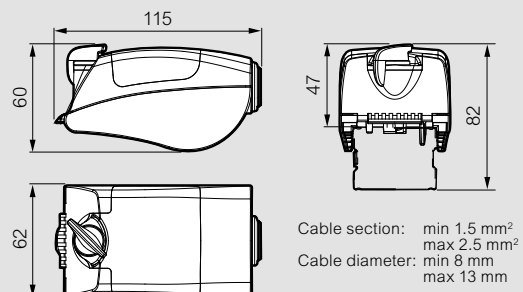

#### End cover (Supplied together with Feed Unit)

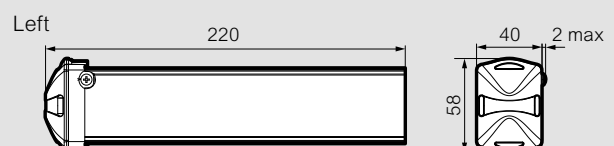
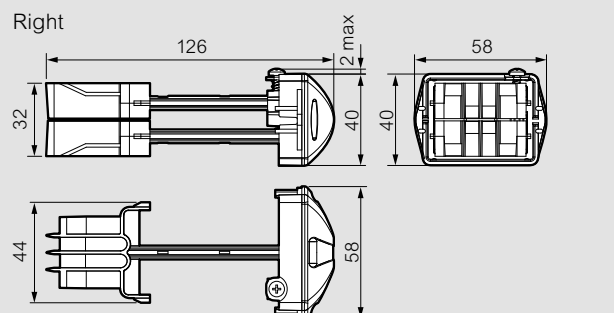

# LBplus data

## quick selection table

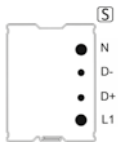
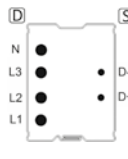
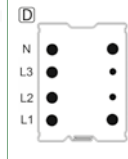
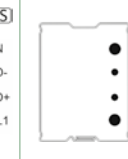
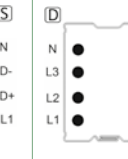
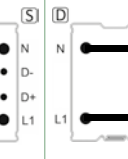
						
	252 + DATA	254 + DATA	256 + DATA	402 + DATA	406 + DATA	632 + DATA
<b>STRAIGHT LENGTHS TYPE A WITH BUS</b>						
3 m length - 4, 4+4 and 4+2 outlets	75160102D	75170102D	75180102D	75200102D	75220102D	75240102D
1.5 m length - 2 and 1+1 outlets	75200111D	75220111D	75220111D	75200111D	75220111D	75240111D
<b>FEED UNITS FOR POWER AND DATA BUS</b>						
RH feed unit + RH end cover	75161001D	75221001D	75221001D	75201001D	75221001D	75241001D
LH feed unit + LH end cover	75201002D	75221002D	75221002D	75201002D	75221002D	75241002D
Centre feed unit	75201151D	75221151D	75221151D	75201151D	75221151D	75241151D
<b>FLEXIBLE ELEMENTS FOR PATH CHANGE</b>						
Flexible joint	75201261D	75221261D	75221261D	75201261D	75221261D	75241261D
<b>POWER AND DATA TAP-OFF PLUGS</b>						
L1-N + DATA 16 A plug with 1 m cable 5G1.5 (H05VVF)	75005005D	-	75005005D	75005005D	75005005D	75005005D
L1-N + DATA 16 A plug with 1 m cable 5G1.5 (FG7OM1)	75005006D	-	75005006D	75005006D	75005006D	75005006D
Kit - Plug 16A with selecting phase (L-N) + plug 10A only DATA BUS, cable 1m 5G1,5 (H05VVF)	-	75005007D	75005007D	75005007D	75005007D	75005007D
Kit - Plug 16A with selecting phase (L-N) + plug 10A only DATA BUS, cable 1m 5G1,5 (FG7OM1)	-	75005008D	75005008D	75005008D	75005008D	75005008D
<b>TAP-OFF PLUGS ONLY DATA</b>						
"DATA only" plug with 1m cable D1-D2 (H05VVF)	75005014D	75005014D	75005014D	75005014D	75005014D	75005014D
"DATA only" plug with 1m cable D1-D2 (FG7OM1)	75005064D	75005064D	75005064D	75005064D	75005064D	75005064D
<b>BRACKETS</b>						
Suspension bracket 60 kg (LBplus - TYPE A)	75003000	75003000	75003000	75003000	75003000	75003000
Hook for lamp	75003001	75003001	75003001	75003001	75003001	75003001
Ring	75003002	75003002	75003002	75003002	75003002	75003002
Pigtail for chain	75003005	75003005	75003005	75003005	75003005	75003005
Bracket for cable channel	75003006	75003006	75003006	75003006	75003006	75003006
5m steel cable with self locking clamp	75003008	75003008	75003008	75003008	75003008	75003008
Bracket with 3m steel cable	75003009	75003009	75003009	75003009	75003009	75003009

S: Single  
D: Double

### EXAMPLE OF INSTALLATION DIAGRAM

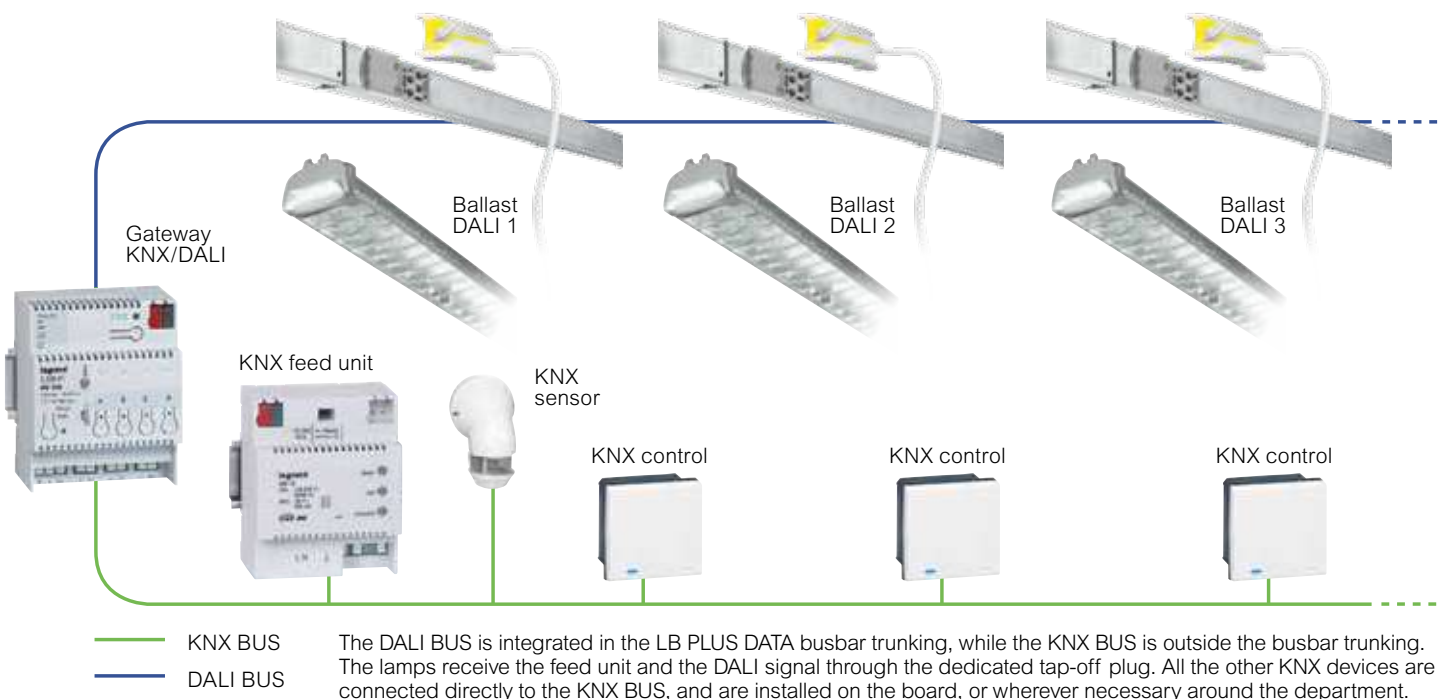

# LBplus data

## technical data

LBPLUS DATA			TYPE A					
			252 DATA	254 DATA	256 DATA	402 DATA	406 DATA	632 DATA
Number of live conductors			2+2 DATA	4+2 DATA	6+2 DATA	2+2 DATA	6+2 DATA	2+2 DATA
Overall dimension of the busbars	LxH	[mm]	35 x 46	35 x 46	35 x 46	35 x 46	35 x 46	35 x 46
Rated current	I <sub>n</sub>	[A]	25	25	25	40	40	63
Operational voltage	U <sub>e</sub>	[V]	400	400	400	400	400	400
Insulational voltage	U <sub>i</sub>	[V]	500	500	500	500	500	500
Frequency	f	[Hz]	50/60	50/60	50/60	50/60	50/60	50/60
Rated short-time current (0.1 s)	I <sub>cw</sub>	[kArms]	-	2,2	2,2	-	2,7	2,7
Peak current	I <sub>pk</sub>	[kA]	-	3,3	3,3	-	4,1	4,1
Single phase rated short-time current (0,1 s)	I <sub>cw</sub>	[kArms]	1,3	1,3	1,3	1,6	1,6	1,6
Singlephase Peak current	I <sub>pk</sub>	[kA]	2,0	2,0	2,0	2,4	2,4	2,4
Thermal limit	I <sup>2</sup> t	[A <sup>2</sup> s x 10 <sup>3</sup> ]	0,174	0,484	0,484	0,262	0,729	0,729
Phase resistance (20 °C)	R <sub>20</sub>	[mΩ/m]	4,761	4,761	4,761	3,190	3,190	1,595
Phase resistance at thermal conditions	R <sub>t</sub>	[mΩ/m]	5,656	5,656	5,656	3,802	3,802	1,901
Phase reactance (50 Hz)	X	[mΩ/m]	0,229	0,229	0,229	0,236	0,236	0,118
Phase impedance	Z	[mΩ/m]	4,767	4,767	4,767	3,199	3,199	1,599
Resistance of protective conductor (sheet)	R <sub>PE</sub>	[mΩ/m]	1,695	1,695	1,695	1,695	1,695	1,695
Reactance of the protective bar (50 Hz)	X <sub>PE</sub>	[mΩ/m]	0,222	0,222	0,222	0,222	0,222	0,222
Resistance of the fault loop	R <sub>o</sub>	[mΩ/m]	6,456	6,456	6,456	4,885	4,885	3,290
Reactance of the fault loop	X <sub>o</sub>	[mΩ/m]	0,451	0,451	0,451	0,458	0,458	0,340
Impedance of the fault loop	Z <sub>o</sub>	[mΩ/m]	6,472	6,472	6,472	4,906	4,906	3,308
Voltage drop with distributed load referred to V3f (**)	ΔV 10 <sup>-3</sup> cosφ = 0,7	[V/m/A]	4,123*	3,570	3,570	2,830*	2,451	1,225
	ΔV 10 <sup>-3</sup> cosφ = 0,75	[V/m/A]	4,393*	3,805	3,805	3,008*	2,605	1,302
	ΔV 10 <sup>-3</sup> cosφ = 0,8	[V/m/A]	4,662*	4,038	4,038	3,183*	2,757	1,378
	ΔV 10 <sup>-3</sup> cosφ = 0,85	[V/m/A]	4,928*	4,268	4,268	3,356*	2,906	1,453
	ΔV 10 <sup>-3</sup> cosφ = 0,90	[V/m/A]	5,190*	4,495	4,495	3,525*	3,052	1,526
	ΔV 10 <sup>-3</sup> cosφ = 0,95	[V/m/A]	5,445*	4,715	4,715	3,686*	3,192	1,596
	ΔV 10 <sup>-3</sup> cosφ = 1	[V/m/A]	5,656*	4,898	4,898	3,802*	3,293	1,646
Weight	ρ	[kg/m]	1,04	1,25	1,28	1,19	1,56	1,56
Fire load		[kWh/m]	1,0	1,9	1,9	1,0	1,9	1,9
Degree of protection	IP		55	55	55	55	55	55
Degree of impact resistance	IK		07	07	07	07	07	07
Losses for the Joule effect at nominal current	P	[W/m]	10,6	10,6	10,6	18,2	18,2	22,6
Ambient temperature min./MAX.	t	[°C]	-5/50	-5/50	-5/50	-5/50	-5/50	-5/50

(\*) Single phase values with distributed load

(\*\*) **THREE-PHASE:**  $\Delta V_{3f} = \sqrt{3}/2 \times (R_t \cos\phi + X \sin\phi)$   
 $\Delta V_{3f}(In) = I \times L \times \Delta V_{3f}$ : (knowing the current and length of the line)  
 $\Delta V_{3f}(In)\% = (\Delta V_{3f}(In) / U_e) \times 100 (\%)$

To calculate the **ΔV1f (SINGLE-PHASE) on distributed load:**

$\Delta V_{1f} = 1/2 \times (2R_t \cos\phi + 2X \sin\phi)$   
 $\Delta V_{1f}(In) = I \times L \times \Delta V_{1f}$ : (knowing the current and length of the line)  
 $\Delta V_{1f}(In)\% = (\Delta V_{1f}(In) / U_e) \times 100 (\%)$

I = operating current (A)

L = length (m)

### Protection from short circuit (I<sub>n</sub> ≤ 100 A).

Legrand busbar trunking systems with a rated current lower than or equal to 100 A (LBplus - MS 63 e 100) are properly protected through an MCB (Modular Circuit Breaker) with a rated current lower than or equal to that of the busbar. This protection is guaranteed up to the MCB breaking capacity

### Product fully in compliance with the standard: IEC 61439-6, CEI EN 61439-6

#### Temperature rating schedule according to the room temperature

Room temperature [ °C ]	15	20	25	30	35	<b>40</b>	45	50	55	60
Kt factor	1.15	1.12	1.08	1.05	1.025	<b>1</b>	0.975	0.95	0.93	0.89

Multiplier coefficient of rated current for room temperature values different from 40° C

#### Mechanical loads permitted table

The table shows the maximum weights (kg) that can be supported, both for concentrated, and distributed loads

LBplus data	Distance between suspension brackets	Concentrated load	Distributed load
	1.5 m	40 kg	50 kg/m (75 kg)**
2 m	30 kg	30 kg/m (60 kg)**	
3 m	20 kg	13 kg/m (39 kg)**	

\*\* Distributed load total weight



# MINISBARRE (MS)

The compact solution for medium power distribution

## BUSBAR 63, 100 AND 160 A

**MS (Mini busbar)** is the smallest range of the medium power range, ideal for the powering of lighting bodies in small-medium companies. Thanks to its characteristics, and the wide range of accessories and tap-off boxes available, the MS range is the best compromise in all the medium power applications of the service sector. With the MS range, there is absolute confidence that the power is distributed in a safe way, with the best performance.

## Range

The main features of the **MS range** are:

- speed, simplicity, and flexibility during the installation and the design of the paths;
- strength, in spite of the compact sizes;
- availability of tap-off boxes with internal room for up to 16 DIN modules;
- compliance with the IEC 61439-6 standard;
- reference room temperature 40 °C.
- the whole busbar is "fire retardant" in accordance with EN 60332-3.

### WIDE RANGE OF TAP-OFF BOXES

The range of tap-off boxes of the MS busbar family is capable of meeting all the needs of the customer.

### SIMPLE INSTALLATION

The busbars and the accessories making up the system can be installed very easily.

### QUALITY MATERIAL

Each system component is made using high quality materials, in compliance with the technical and safety requirements of the standards. During each manufacturing process stage, maximum attention is given to each and every element.

### FAST AND SIMPLE CONNECTION

The connection between straight elements is simple and quick. With one simple operation, it is possible to obtain both the electrical and the mechanical connection, ensuring at the same time an IP40 protection degree. The application of a sleeve on the joint and a shutter for each window (without box), gives the possibility to increase the protection degree to IP55



LABORATORIES



SMALL OR MEDIUM FACTORIES

## Installation fields

The **MS range** is widely used in labs, small to medium companies, warehouses, and in all the service sector structures, where there is a need for electric power distribution for medium power systems.

## Installation accessories



Intermediate feed unit



Flexible joint



Tap-off boxes



IP55 kit sets



Tap-off boxes

# TRUNKING COMPONENTS AND ADDITIONAL ELEMENTS



Feed units.

Joint cover.  
It ensures the IP55  
degree of protection  
of the junction.

Tap-off box complete with terminals  
for cables of up to 25 mm<sup>2</sup>. Made from  
self-extinguishing plastic material, high  
mechanical resistance and resistance  
to static currents. The Box can be  
connected and disconnected when  
energized. Capacities from 16A to 32A.

Depending on the different installation requirements Legrand range can provide various technical solutions:

- a) 90° angles: available for carrying out changes of direction both horizontally and vertically. There is a quick connection, as with the straight elements. The standard is IP40 degree of protection (to reach IP55 is necessary include the specific accessory);
- b) T-type and X-type elements: available on request for special applications;
- c) flexible angle: available for 63A, 100A and 160A capacities and allows changes of direction with angles different, horizontal and vertical, from 90°;
- d) straight elements with flame barrier (internal + external). These elements - used when it is necessary to move through fire-resistant walls - have been tested in laboratories (in compliance with DIN Standards 4102-9 and EN 1366-3) to confirm that, if correctly installed, they can maintain the intrinsic fire-resistant properties of the wall;
- e) **Vertical Installation (riser mains)\***  
straight elements with bar lock: when the busbar is installed vertically (riser mains) these elements are equipped with a device that prevents the conductors from sliding due to the weight of the portion of column over it. This type of element is required at about every 10 m of column.

\* For this quotation please contact Legrand

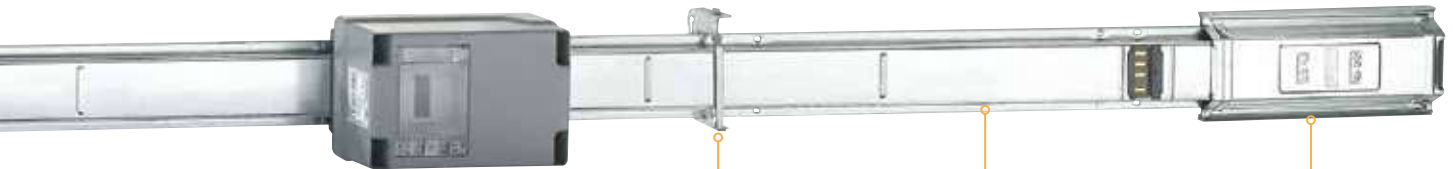

Wall suspension bracket or bracket for connecting a support.

Straight elements, with tap-off outlets every 1000 mm from both sides.

End cover: completes the installation of the lines and guarantees the IP55 degree of protection of the line.



# Minisbarre (MS) 63, 100, 160 A

## trunking components

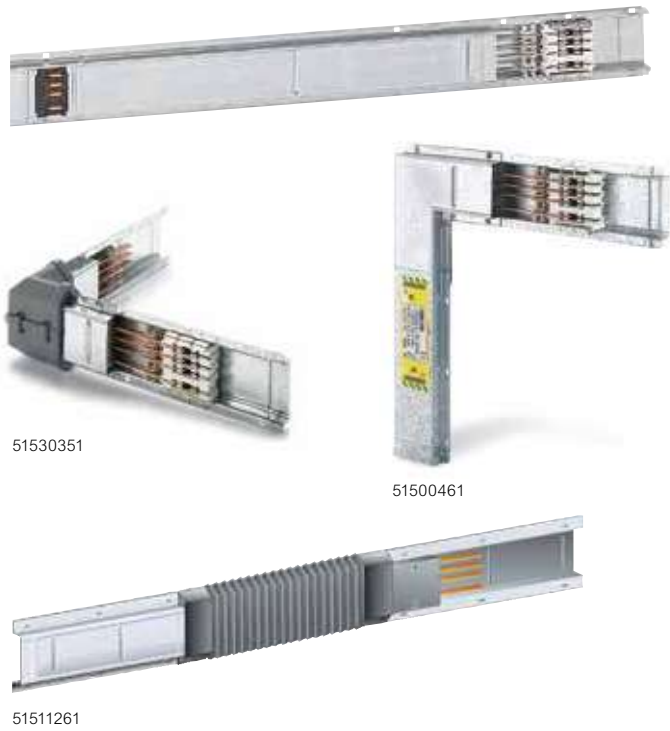

Reference standard: IEC 61439-6  
 Reference temperature: 40 °C  
 Degree of Protection: IP 40/55  
 Thickness: 0.8 mm;  
 Dimension: 39x97mm;  
 N° of conductors: 4 with equal section 3P+N  
 Conducting «fire retardant» in accordance with EN 60332-3  
 Separation between the conductors by plastic insulators reinforced with 20% glass fiber, which guarantees a degree of V1 self-extinguishing (according to UL94) and conform to the glow-wire test according to IEC 60695-2-10

Pack	Cat.Nos			Straight elements	
	MS63 (63A)	MS100 (100A)	MS160 (160A)	L (m)	Outlets
1	51530101	51510101	51520101	3	3+3
1	51530116	51510116	51520116	2	2+2
1	51530115	51510115	51520115	1.5	1+1
1	51530114	51510114	51520114	1	1+1
1	51530112	51510112	51520112	<1.5	*
1	51530113	51510113	51520113	>1.5	*

				Flexible joint (elbow) - IP55	
	MS63	MS100	MS160		
1	51511261	51511261	51521261	Flexible joint	

				Elbows - IP55	
	MS63	MS100	MS160	Type	
1	51530351	51500361	51520351	Horizontal	Right
1	51530361	51500362	51520361		Left
1	51530451	51500461	51520451	Vertical	Right
1	51530461	51500462	51520461		Left

\*Outlets to be defined in base of the length of element

# Minisbarre (MS) 63, 100, 160 A

## feed units



Pack	Cat.Nos		Feed units	
	MS63 (63 A)	MS100 (100 A)	Description	Type
2	51511051	51511051	Head	Right
2	51511052	51511052		Left
1	51511151	51511151	Intermediate	
<b>MS160 (160 A)</b>				
1	51521051		Head	Right
1	51521052			Left
1	51521151		Intermediate	

**Note:** RH-Right, LH-Left

# Minisbarre (MS) 63, 100, 160 A

trunking components and feed units

## Dimensions

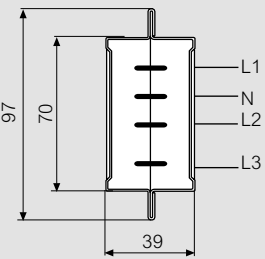
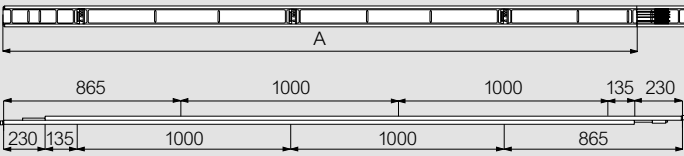

In (A)	Item code	A (m)	Weight (kg)
63	51530101	3	7.890
	51530116	2	5.260
	51530115	1.5	3.945
	51530114	1	2.630
	51530112	< 1.5	-
100	51510101	3	7.890
	51510116	2	5.260
	51510115	1.5	3.945
	51510114	1	2.630
	51510112	< 1.5	-
160	51520101	3	9.290
	51520116	2	6.190
	51520115	1.5	4.645
	51520114	1	3.100
	51520112	< 1.5	-

## Horizontal elbow Right

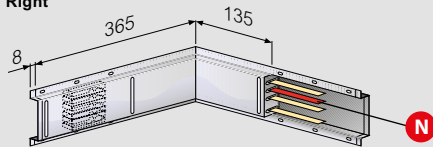

In (A)	Right	Left	Weight (kg)
63	51530351	51530361	1.600
100	51500361	51500362	1.600
160	51520351	51520361	2.600

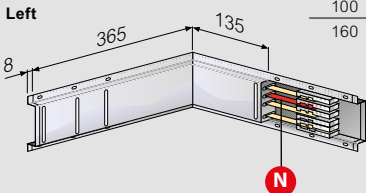

RH and LH elbows are different in the position of the joining block.

## Vertical elbow Right

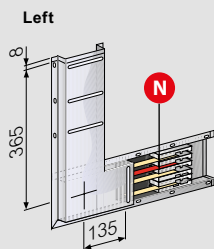
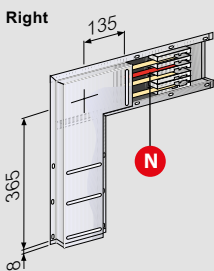

In (A)	Right	Left	Weight (kg)
63	51530451	51530461	1.600
100	51500461	51500462	1.700
160	51520451	51520461	2.700

## Flexible joint (Art. 51511261 and 51521261)

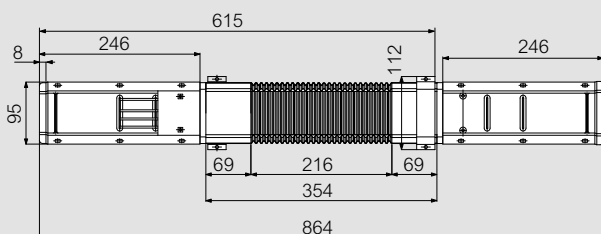

## MS63 - MS100

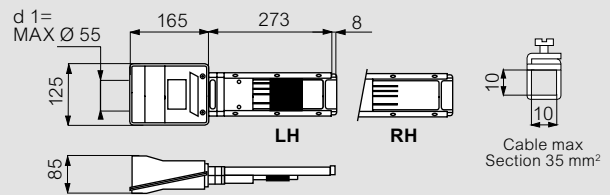

Item code	Weight (kg)
51511051 (RH)	1.732
51511052 (LH)	1.874

## MS160

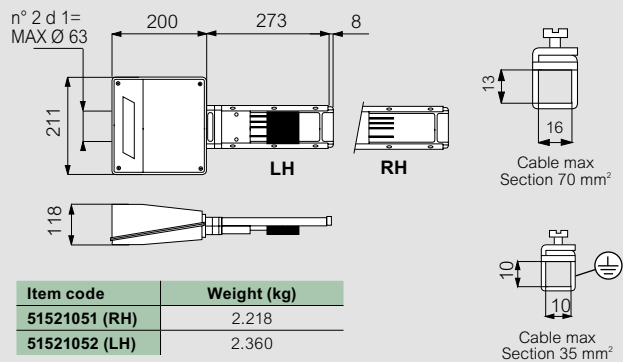

Item code	Weight (kg)
51521051 (RH)	2.218
51521052 (LH)	2.360

Versions with switch disconnecter are also available on request

## Intermediate feed unit MS63 - MS100

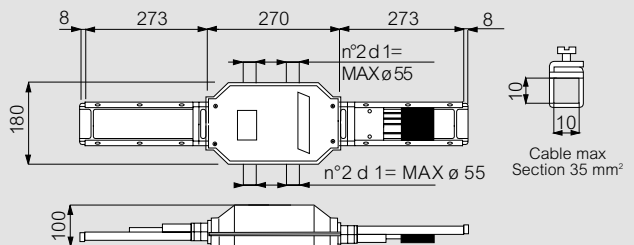

Item code	Weight (kg)
51511151	3.500

## MS160

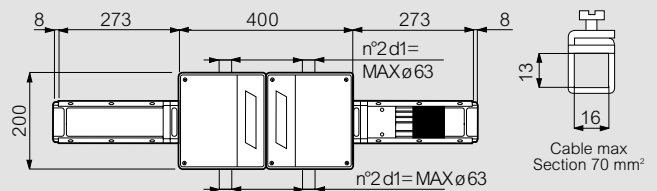

Item code	Weight (kg)
51521151	5.000

# Minisbarre (MS) 63, 100, 160 A

tap-off boxes



Pack	Cat.Nos	Tap-off boxes	In (A)
1	51515071	Type and description	32
1	51515076*	1 Empty with 4 module DIN rail	32
1	51515077*	1 With fuse carrier CH10 (10.3x38mm)	32
1	51515078*	1 With D01 fuse carrier	16
1	51515078*	1 With D02 fuse carrier	32
1	51515072	1 For 4 DIN rail modules cover junction	32
1	51515073	2 Empty with 8 module DIN rail	32
1	51515074	2 With 4 module DIN rail (long version)	32
1	51515075	2 With 8 module DIN rail (long version)	32

\* Fuses not provided

# Minisbarre (MS) 63, 100, 160 A

tap-off boxes

## Dimensions

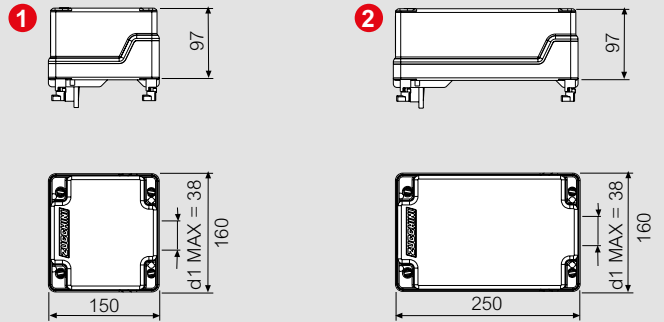

Item code	Weight (kg)
51515071	0.680
51515076	0.680
51515077	0.950
51515078	0.950
51515072	0.730
51515073 *	0.930
51515074 *	0.960
51515075 *	0.990

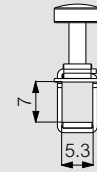

Cable max Section 16 mm<sup>2</sup>

Energy withstand 400.000 A2s  
Power loss 10 W  
Total insulating Tap-off box  
\* Power loss 16 W

## Types of installable boxes

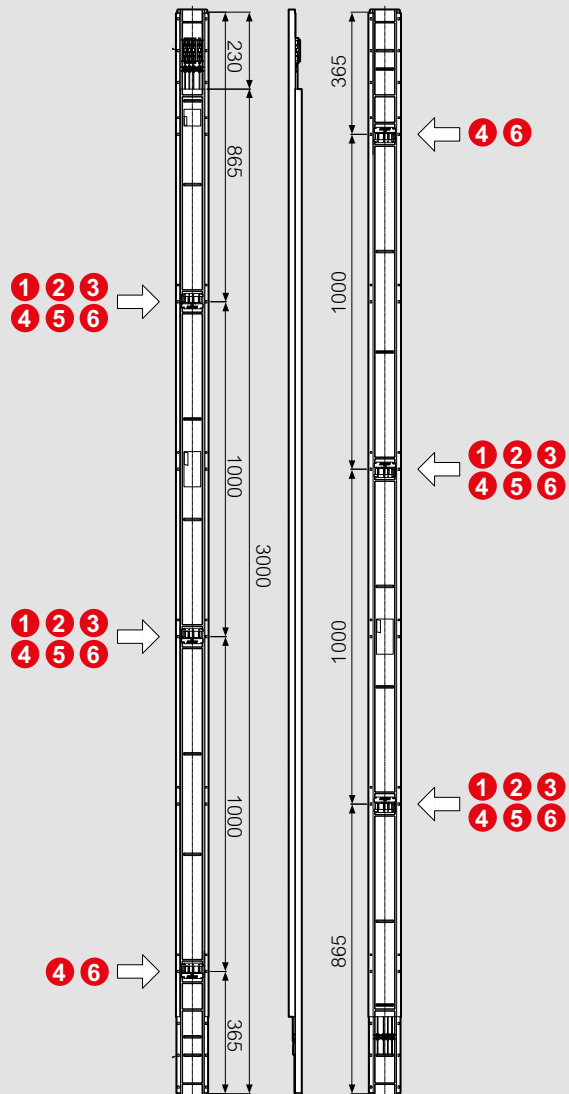

### Type of tap-off boxes

<p>51515071</p>	<p>51515073</p>
<p>51515076 - 51515077 - 51515078</p>	<p>51515074</p>
<p>51515072</p>	<p>51515075</p>

# Minisbarre (MS) 63, 100, 160 A

tap-off boxes



Pack	Cat.Nos	Tap-off boxes with disconnecting device on cover
2	51515051*	<b>3</b> With fuses carrier CH10 (10.3x38mm)
2	51515052*	<b>4</b> With fuses carrier CH14 (14x51mm)
1	51515057	<b>5</b> With transparent cover
1	51515056	<b>5</b> With transparent cover and hinged window (4 modules)
1	51515067	<b>5</b> With hinged window (7 modules)
1	51515058	<b>6</b> With hinged window (16 modules)

\* Fuses not provided

## Type of tap-off boxes

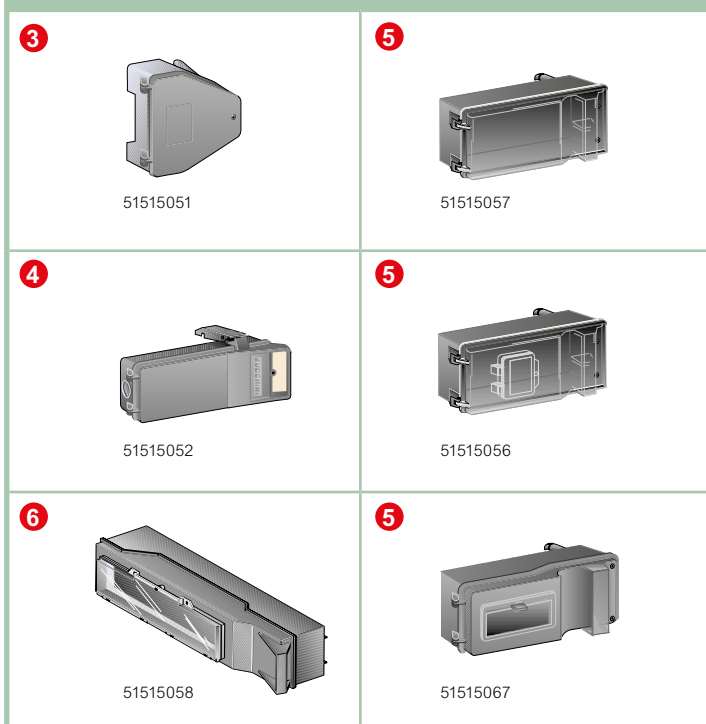

# Minisbarre (MS) 63, 100, 160 A

tap-off boxes

## Dimensions

Art. 51515051  
In= 16 A

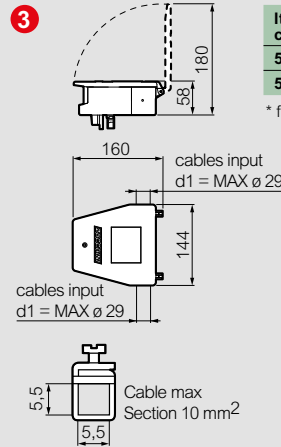

Art. 51515052  
In= 50 A

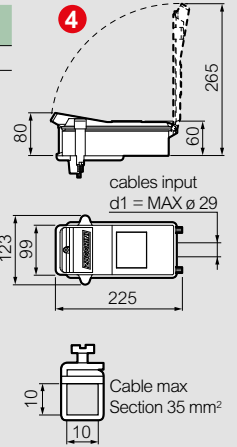

Item code	Weight (kg)
51515051	0.908
51515052	0.908

\* fuses not provided

In= 63 A

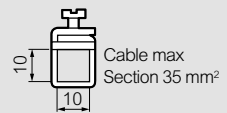
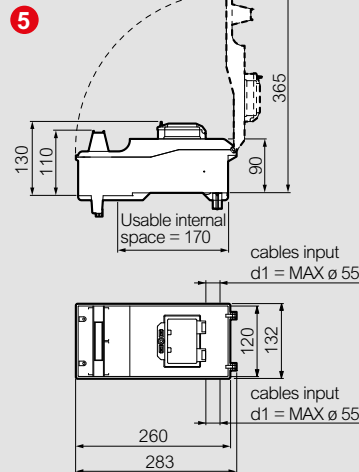

Item code	Weight (kg)
51515057	1.100
51515056	1.200
51515067	1.100

Energy withstand 400.000 A²S  
Power loss 20W

In= 63 A

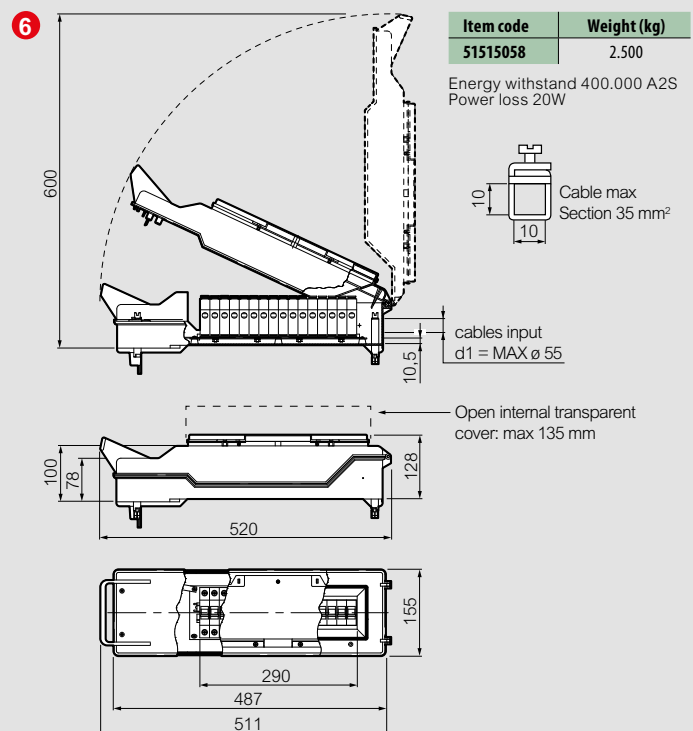

Item code	Weight (kg)
51515058	2.500

Energy withstand 400.000 A²S  
Power loss 20W

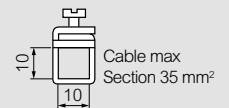

## Minisbarre (MS) 63, 100, 160 A

installation accessories and Fire Barrier



Pack	Cat.Nos	Installation accessories
1	51501351	End cover
5	51500161	IP55 joint cover (one set for each junction)
12	51500160	IP55 outlet cover (6 every 3m straight element)
10	51002002	Suspension bracket (1 bracket every 2 metres)
<b>Kit Fire Barrier E120</b>		
1	515EFB01	External Kit fire barrier (63A-100A-160A)
1	515IFB01	Internal Kit fire barrier (63A-100A-160A)

## Minisbarre (MS) 63, 100, 160 A

installation accessories

### ■ Dimensions

#### End cover 51501351

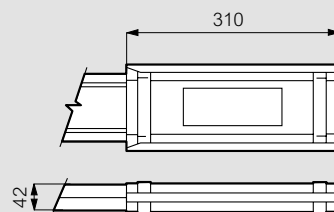

#### IP55 joint cover 51500161

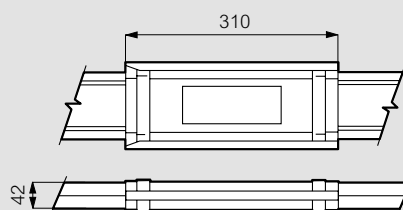

#### Outlet cover 51500160

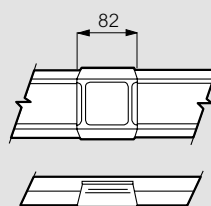

#### Suspension bracket 51002002

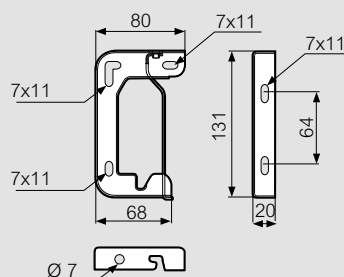

# Minisbarre (MS)

## technical informations

### Straight elements

The components and the features of the MS straight elements are:

- a casing made of quality galvanized steel, with a sheet-metal thickness that allows its use as the protective earth (PE) and ensures the electrical continuity during mounting with no added accessories;
- overall busbar dimensions: 39x97mm;
- number of conductors: 4 with the same cross section 3P+N available for capacities 63A, 100A and 160A;
- separation between the conductors using plastic insulating devices, reinforced with 20% of glass fibres, which are able to ensure a V1 selfextinguishing degree (according to UL94) and are in compliance with the glow-wire test according to IEC 60695-2-10;
- tap-off outlets with a constant centre distance of 1 m on both sides of the busbar (3+3 windows every 3m), set up for being connected to tap-off boxes;
- an electric joint block, with silver-plated copper contacts for automatically connecting live parts and the PE (protective conductor). The connection between two straight elements is quick; with one operation it is possible to have an electric and a mechanical connection; hence, at the same time, an IP40 degree of protection is guaranteed. The upgrade to IP55 is easily obtained by adding joint covers and outlet covers. The whole duct is fire retardant in compliance with the IEC 60332-3 standard

### Fixing support

In order to attach the line to the structure of the building, directly or with wall supports, it is necessary to use a bracket which serves as a collar around the busbar. The bracket has holes to be easily paired with the available supports

### Tap-off boxes

Used to connect and energize one-phase and three-phase loads up to 63A; their features include:

- the PE contact (protective earth) is the first to make an electrical connection when inserting the box into the outlet and it is the last to disconnect when pulling it out;
- compliance with all insulating plastic components according to the glow-wire test (IEC 60695-2-10) with V1 self-extinguishing degree (UL94);
- standard IP55 degree of protection without using additional accessories;
- can be inserted and removed when the busbar is energized and when the fixture is under load, up to a capacity of 32A. These boxes are available in a wide range of versions:
- 63A empty boxes (only with a terminal board for connecting cables), with an internal DIN rail and transparent door;
- 16A - available with a set of three cylindrical fuse carriers CH10 (10.3x38mm);
- 16/32A - available with a set of three cylindrical fuse carriers - DIAZED (D01: 16A; D02: 32A);
- 50A - available with cylindrical fuse carriers (14x51mm);
- 63A - available with 4-7-16 DIN modules;
- 16 to 63A - available with a disconnection device integral with the cover

### Feed unit

Allows you to electrically power the MS line through a cable line; the installation is carried out with a quick junction connection as with the straight elements. The feed units have terminals for the connection of copper cables for sections of up to 35 mm<sup>2</sup> for the 63/100A feed unit and 70 mm<sup>2</sup> for the 160A feed unit. The entrance point of the cables is positioned on the back side of the feed unit. The MS line offers also central feed units as well as power supply boxes with a switch-disconnector which allows you to select the whole line for carrying out maintenance operations or layout changes, if required

### End cover

The end cover ensures the IP55 protection degree at the end of the line

Minisbarra (MS)		63	100	160
N° of live conductors		4	4	4
Overall dimension of the busbars	LxH [mm]	39x97	39x97	39x97
Rated current	I <sub>n</sub> [A]	63	100	160
Operational voltage	U <sub>e</sub> [V]	400	400	400
Insulational voltage	U <sub>i</sub> [V]	750	750	750
Frequency	f [Hz]	50/60	50/60	50/60
Three phase rated short-time current (0,1 s)	I <sub>scw</sub> [kArms]	3,5	5	5,5
Three phase peak current	I <sub>pk</sub> [kA]	5,25	10	10
Thermal limit	I <sup>2</sup> t [A <sup>2</sup> s x 10 <sup>6</sup> ]	1,23	2,5	3,03
Phase resistance at 20 °C	R <sub>20</sub> [mΩ/m]	1,250	0,837	0,478
Phase resistance at thermal conditions	R <sub>t</sub> [mΩ/m]	1,445	1,078	0,650
Phase reactance at 50 Hz	X [mΩ/m]	0,366	0,247	0,247
Phase impedance	Z [mΩ/m]	1,302	0,873	0,538
Resistance of protective conductor (sheet)	R <sub>PE</sub> [mΩ/m]	0,857	0,857	0,857
Reactance of the protective bar at 50 Hz	X <sub>PE</sub> [mΩ/m]	0,102	0,102	0,102
Resistance of the fault loop	R <sub>o</sub> [mΩ/m]	2,11	1,69	1,34
Reactance of the fault loop	X <sub>o</sub> [mΩ/m]	0,468	0,349	0,349
Impedance of the fault loop	Z <sub>o</sub> [mΩ/m]	2,16	1,73	1,38
Voltage drop with distributed load referred to V3f(*)	ΔV 10 <sup>-3</sup> cosφ = 0,7 [V/m/A]	1,102	0,806	0,547
	ΔV 10 <sup>-3</sup> cosφ = 0,75 [V/m/A]	1,148	0,842	0,564
	ΔV 10 <sup>-3</sup> cosφ = 0,8 [V/m/A]	1,191	0,875	0,579
	ΔV 10 <sup>-3</sup> cosφ = 0,85 [V/m/A]	1,231	0,906	0,591
	ΔV 10 <sup>-3</sup> cosφ = 0,90 [V/m/A]	1,264	0,933	0,600
	ΔV 10 <sup>-3</sup> cosφ = 0,95 [V/m/A]	1,288	0,954	0,602
ΔV 10 <sup>-3</sup> cosφ = 1 [V/m/A]	1,251	0,934	0,563	
Weight	ρ [kg/m]	2,0	2,5	2,8
Fire load	[kWh/m]	1,64	1,64	1,64
Degree of protection	IP	40/55	40/55	40/55
Losses for the Joule effect at nominal current	P [W/m]	17,21	32,34	49,93
Ambient temperature min/MAX	t [°C]	-5/50	-5/50	-5/50

(\*) **THREE-PHASE:**  $\Delta V_{3f} = \sqrt{3}/2 \times (R_l \cos\phi + X_l \sin\phi)$   
 $\Delta V_{3f}(I_n) = I \times L \times \Delta V_{3f}$ : (knowing the current and length of the line)  
 $\Delta V_{3f}(I_n)\% = (\Delta V_{3f}(I_n) / U_e) \times 100 (\%)$

To calculate the **ΔV1f (SINGLE-PHASE) on distributed load:**  
 $\Delta V_{1f} = 1/2 \times (2R_l \cos\phi + 2X_l \sin\phi)$   
 $\Delta V_{1f}(I_n) = I \times L \times \Delta V_{1f}$ : (knowing the current and length of the line)  
 $\Delta V_{1f}(I_n)\% = (\Delta V_{1f}(I_n) / U_e) \times 100 (\%)$

I = operating current (A)  
L = lenght (m)





# MEDIUM RATING (MR)

Performance  
and functionality in  
medium power

## BUSBAR FROM 160 TO 1000 A

**MR (Medium Rating)** is the range dedicated to the distribution of power in medium to large companies, in riser power supplies (light wells), in service sector buildings (banks, insurance companies, offices, Data Center, etc.).

### Range

The main features of the **MR range** are:

- speed, simplicity, and flexibility during the installation and the design of the paths;
- availability in various sizes: from 160 A up to 1000 A with aluminium alloy conductors, and from 250 A to 1000 A with 99.9% electrolytic copper conductors;
- compliance with the IEC 61439-6 standard;
- reference room temperature 40 °C.

#### WIDE RANGE OF TAP-OFF BOXES

The range of tap-off boxes of the MR busbar family is capable of meeting all the needs of the customer. Tap-off boxes from 16 A to 1000 A are available, inside which it is possible to house protection devices, such as fuses, small size circuit breakers, and/or boxed circuit breakers

#### QUALITY MATERIAL

Each system component is made using high quality materials, in compliance with the technical and safety requirements of the standards. During each manufacturing process stage, maximum attention is given to each and every element.

#### STURDINESS AND FUNCTIONALITY

MR busbars guarantee maximum system functionality thanks to careful design of the components, easy to install, and the construction characteristics, which make MR busbars among the strongest on the market.

#### MAXIMUM ADVANTAGE IN DISTRIBUTION

The MR range is even more advantageous in Data Center and Vertical (riser column) applications, which do not require busbar blocking elements, or thermal expansion elements. The monobloc that distinguishes the MR range compensates the thermal expansion of conductors.

## Installation fields

The typical applications where the **MR busbars** can be used are:

- industry,
- skyscrapers,
- hospitals,
- data center,
- shopping centres...

and everywhere there is the need for power distribution (up to 1000 A)



HIGH-RISE BUILDINGS



DATA CENTER



INDUSTRIES

## Installation accessories



Feed unit



Feed Unit for Electric Panel and Transformers



Horizontal elbow



Vertical elbow



End cover



Outlet cover



Tap-off box



Tap-off box for MCB's

# FEATURES

## PRE-ASSEMBLED MONOBLOC

All trunking components (straight elements, angles, etc.) are provided with a pre-assembled monobloc which considerably speeds up the installation of the system and makes transportation and storage operations easier.

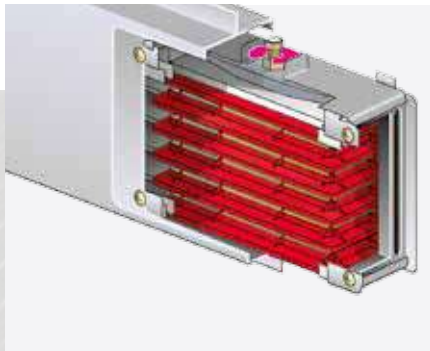

## EXTREMELY FAST INSTALLATION

The monobloc and the "dynamometric" nut allow a very fast installation of the whole line

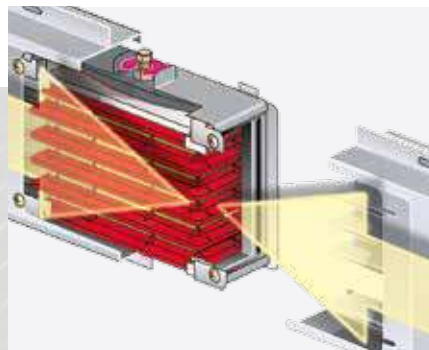

## DYNAMOMETRIC MONOBLOC

Tighten the "dynamometric" bolt on the monobloc until the head breaks to electrically connect the elements. The breakage of the nut head guarantees long-lasting reliability and safety. The connection is maintenance free. In case of a future intervention on the line, the monobloc must be retightened using the second nut head with a torque wrench at the correct settings (see installation manual).

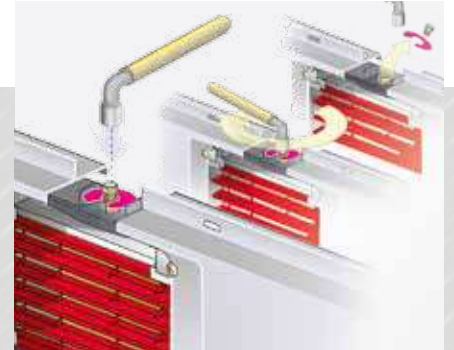

## CONNECTION FLANGES

If the monobloc has been tightened improperly, the head of the dynamometric nut will prevent the mechanical coupling from closing. The connection flanges and the seals serve as a protection for the element during transportation and ensure their degree of protection as well as their mechanical rigidity when being installed.



## PROTECTION DEGREE

The MR line position has a standard IP55 protection degree.



## EXCELLENT FIRE RESISTANCE

The MR line has elements provided with a flame barrier (S120 according to IEC EN 1366) and structures which guarantee that the bus-line continues to function in case of fire (E120 according to IEC EN 1366). The fire load of the MR line is extremely low compared to the quantity of plastic materials needed to insulate cables with the same capacity.



### GLOW-WIRE TEST

All plastic materials are resistant and in compliance with the "glow-wire" test (IEC EN61439-6).



### VERSIONS

The MR symbol indicates a busbar with 4 conductors with an equal cross section (3L+N), and the casing acts as the protective earth conductor (PE); the MRf (full) line has 5 conductors with an equal cross section (3L+N+PE).

The MR and MRf lines are also available on request in a painted version (RAL to be defined by the customer).

\*MR/MRf 1000A Al is painted with RAL 7035

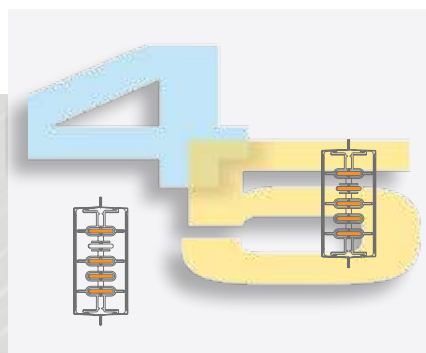

### SIMPLE AND RELIABLE

The "monobloc" connection of the MR line is able to compensate for any heat expansion affecting the conductors, thus avoiding the need to insert special expansion elements even in considerably long systems. If the MR line is installed vertically (riser main) there is no need to install busbar thrust units because the monobloc prevents the conductors from sliding.

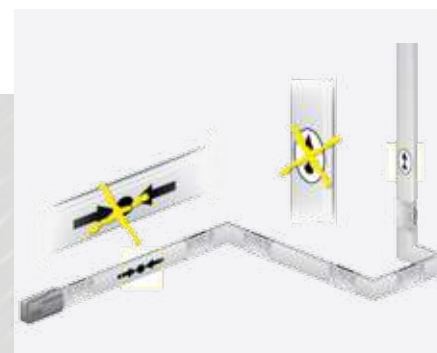

### MAXIMUM STRENGTH

The MR range has been designed and manufactured for heavy industrial environments. The degree of impact-resistance of the casing which houses this line is the maximum stated in IEC EN60068-2-62: IK10.



### ALUMINIUM AND COPPER RATING

<b>Al</b>	160	250	315	400	500	630	800	1000
<b>Cu</b>	-	250	315	400	-	630	800	1000



# TRUNKING COMPONENTS AND ADDITIONAL ELEMENTS



Feed units.

Joint cover pre-installed on the elements.

Tap-off box complete with terminals for cables of up to 25 mm. Made from self-extinguishing plastic material, ensures high mechanical resistance and resistance to static currents. Plug-in type boxes can be inserted and removed when the busbar is energized.

Depending on the different installation requirements Legrand can provide various technical solutions:

- a) 90° elbows: available for carrying out changes of direction both horizontally and vertically. There is a quick connection, as for the straight elements. The standard degree of protection is IP55;
- b) T-type and X-type elements, Z-type double elbows available. The standard degree of protection is IP55;
- c) straight elements with fire barrier (internal + external) S120 (certified for 120min). Tested in laboratories (in compliance with DIN Standards 4102-9 and EN 1366-3) to confirm that, correctly installed, they maintain the intrinsic fire-resistant properties of the wall;

- d) straight elements with 5 outlets on one side; they are ideal for riser mains or segments with a large number of derivations;
- e) straight elements with 5+5 outlets on two side; they are ideal for data center solutions;
- f) straight elements with no outlets, used for energy transport only.

The MR line is even more advantageous in vertical applications (riser mains) as no thrust unit or thermal expansion element is necessary.

The MR monobloc is designed to compensate the thermal expansions of the conductors.

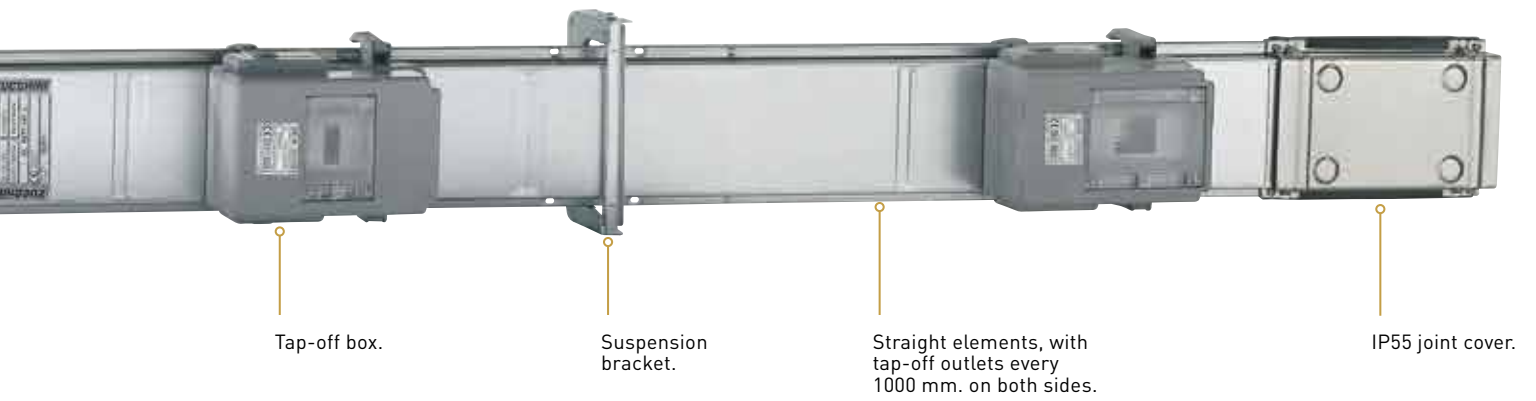

# Medium Rating (MR) 160 - 1000 A

## line route

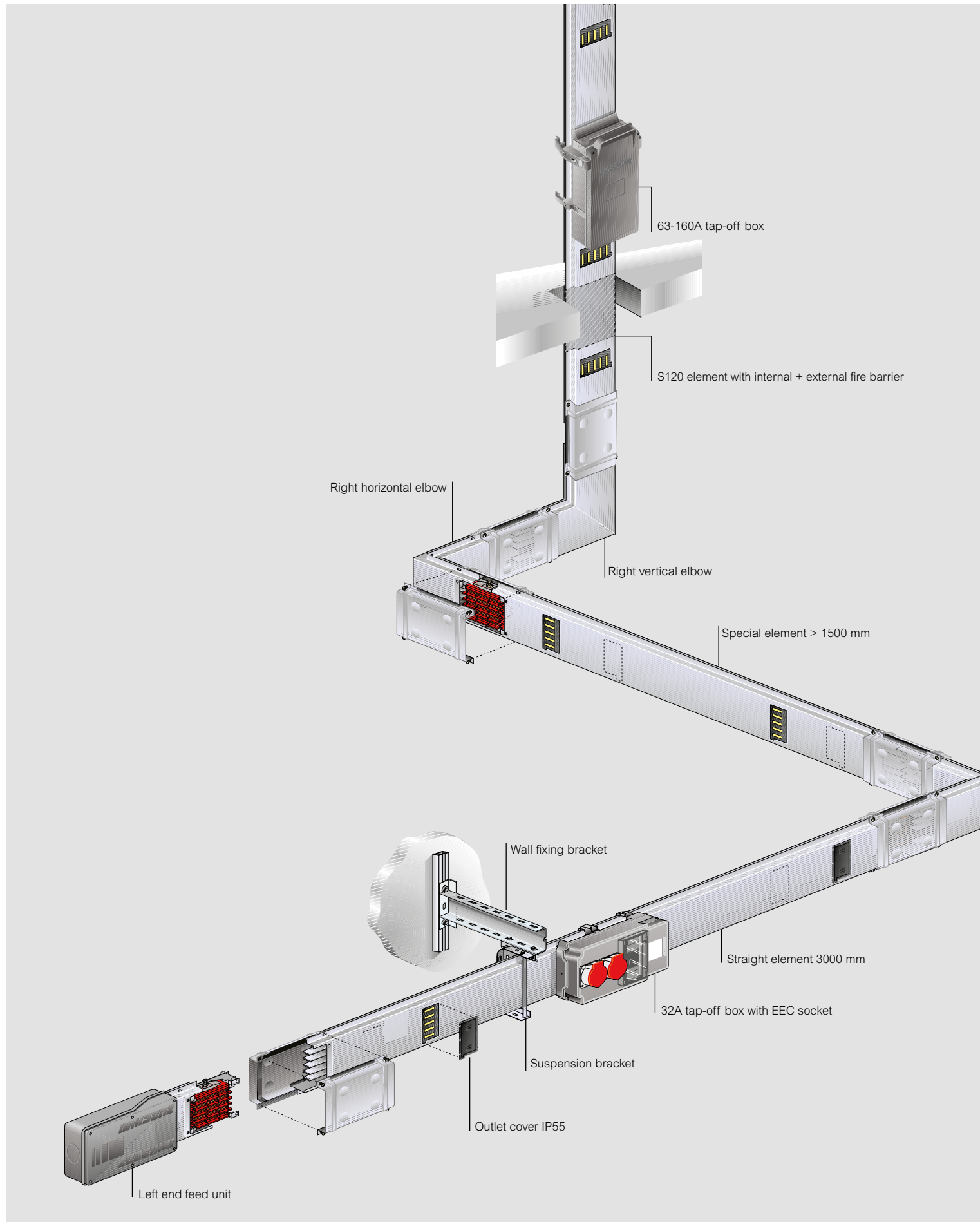

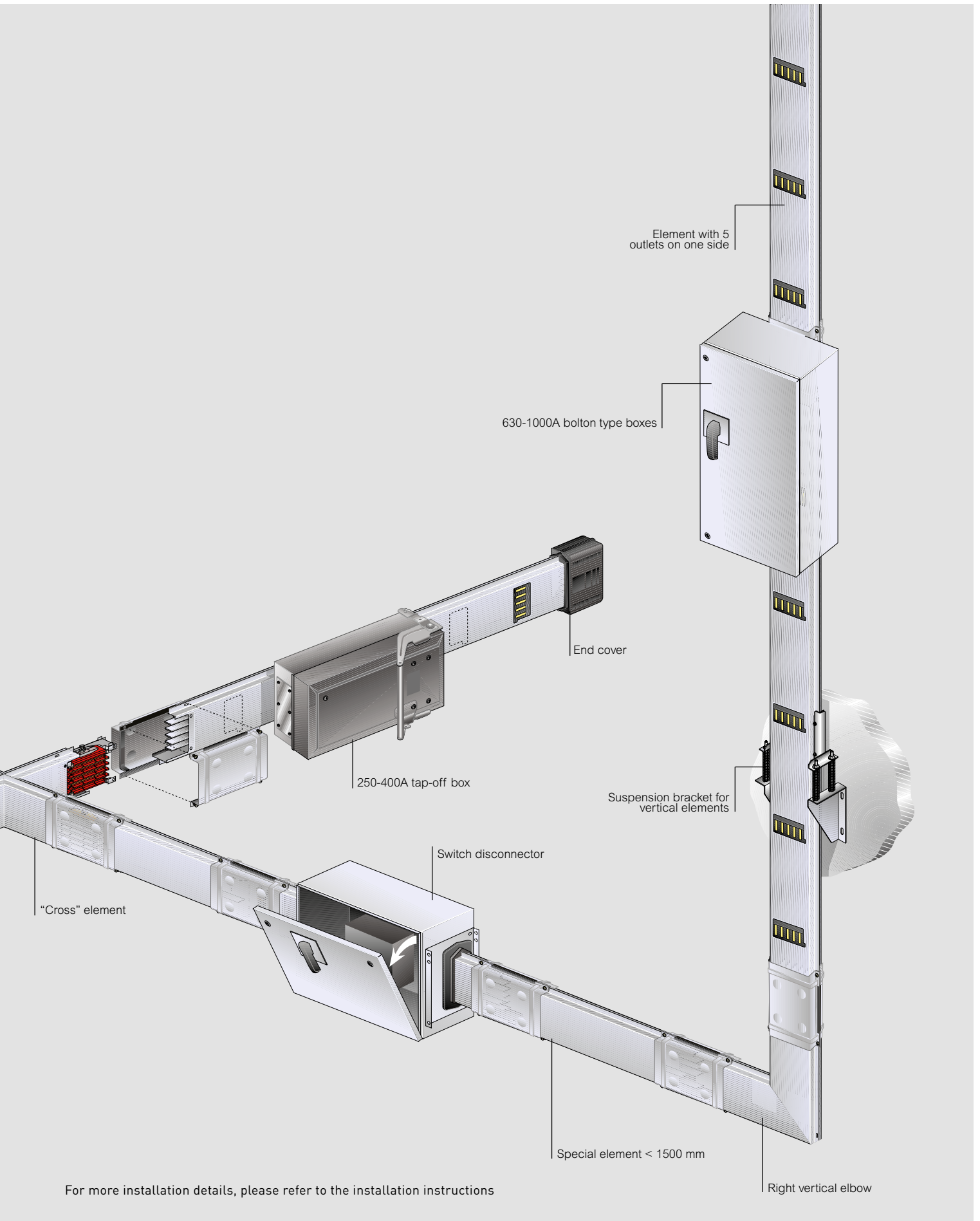

# Medium Rating (MR) 160 - 1000 A

straight elements



Reference standard: IEC 61439-6  
 Reference temperature: 40 °C  
 Protection degree: IP55  
 Thickness: 0.8 mm;  
 Dimension (LxH): 75-135x196mm;  
 N° of conductors: 4 with equal section 3P+N or 5 when using MRfull (3P+N+PE)  
 Conducting «fire retardant» in accordance with EN 60332-3  
 Separation between the conductors by plastic insulators reinforced with 20% glass fiber, which guarantees a degree of V1 self-extinguishing (according to UL94) and conform to the glow-wire test according to IEC 60695-2-10

Pack	Cat.Nos		Straight elements without windows	
	Al	Cu	In (A)	L (mm)
1	50400111	-	160	600÷1500
1	50400112	55400112	250	
1	50400113	55400113	315	
1	50400114	55400114	400	
1	50400118	-	500	
1	50400115	55400115	630	
1	50400116	55400116	800	
1	50400117	55400117	1000	
1	50400121	-	160	1501÷2999
1	50400122	55400122	250	
1	50400123	55400123	315	
1	50400124	55400124	400	
1	50400128	-	500	
1	50400125	55400125	630	
1	50400126	55400126	800	
1	50400127	55400127	1000	
1	50400241	-	160	3000
1	50400242	55400242	250	
1	50400243	55400243	315	
1	50400244	55400244	400	
1	50400248	-	500	
1	50400245	55400245	630	
1	50400246	55400246	800	
1	50400247	55400247	1000	

0 - 4 Conductors, galvanized (MR)  
 1 - 5 Conductors, galvanized (MRf)  
 2 - 4 Conductors, painted (MR-P)  
 3 - 5 Conductors, painted (MRf-P)

# Medium Rating (MR) 160 - 1000 A

straight elements

## Dimensions

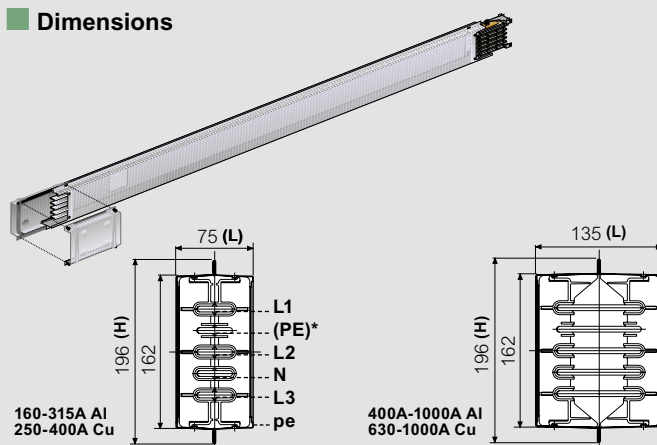

\* only on MRf

## For straight elements = 3000 mm

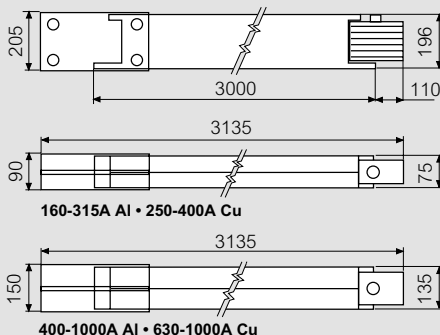

## For straight elements at measurement from 600 mm to 2999 mm

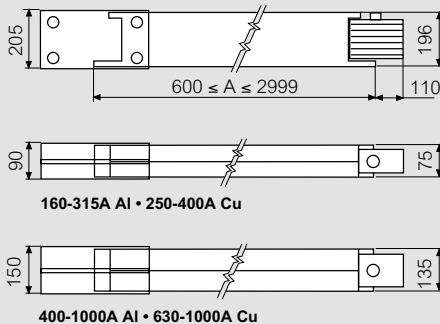

In your Purchase Order please specify the required length (see page: How to take measurements)

Al	Weight (kg)	Cu	Weight (kg)	In (A)
5040 01 11	13.6	-	-	160
5040 01 12	14.1	5540 01 12	16.5	250
5040 01 13	14.9	5540 01 13	17.7	315
5040 01 14	23.3	5540 01 14	22.0	400
5040 01 18	25.2	-	-	500
5040 01 15	26.9	5540 01 15	34.3	630
5040 01 16	28.0	5540 01 16	42.2	800
5040 01 17	30.1	5540 01 17	47.8	1000
5040 01 21	13.6	-	-	160
5040 01 22	14.1	5540 01 22	16.5	250
5040 01 23	14.9	5540 01 23	17.7	315
5040 01 24	23.3	5540 01 24	22.0	400
5040 01 28	25.2	-	-	500
5040 01 25	26.9	5540 01 25	34.3	630
5040 01 26	28.0	5540 01 26	42.2	800
5040 01 27	30.1	5540 01 27	47.8	1000
5040 02 41	19.9	-	-	160
5040 02 42	20.9	5540 02 42	25.7	250
5040 02 43	22.8	5540 02 43	28.1	315
5040 02 44	33.8	5540 02 44	36.9	400
5040 02 48	37.5	-	-	500
5040 02 45	41.7	5540 02 45	56.0	630
5040 02 46	44.3	5540 02 46	72.1	800
5040 02 47	46.8	5540 02 47	83.7	1000

In the case of transport of electric energy is recommended to use SCP busbar duct

## Medium Rating (MR) 160 - 1000 A

straight elements (continued)



50400104

Pack	Cat.Nos		Straight elements with windows		
	Al	Cu	In (A)	L (mm)	N° windows
1	50400141	-	160	1000 ÷ 1500	1+1
1	50400142	55400142	250		
1	50400143	55400143	315		
1	50400144	55400144	400		
1	50400148	-	500		
1	50400145	55400145	630		
1	50400146	55400146	800		
1	50400147	55400147	1000		
1	50400151	-	160	1501 ÷ 2999	2+2
1	50400152	55400152	250		
1	50400153	55400153	315		
1	50400154	55400154	400		
1	50400158	-	500		
1	50400155	55400155	630		
1	50400156	55400156	800		
1	50400157	55400157	1000		
1	50400101	-	160	3000	3+3
1	50400102	55400102	250		
1	50400103	55400103	315		
1	50400104	55400104	400		
1	50400108	-	500		
1	50400105	55400105	630		
1	50400106	55400106	800		
1	50400107	55400107	1000		
1	50400251	-	160	3000	5
1	50400252	55400252	250		
1	50400253	55400253	315		
1	50400254	55400254	400		
1	50400258	-	500		
1	50400255	55400255	630		
1	50400256	55400256	800		
1	50400257	55400257	1000		

## Medium Rating (MR) 160 - 1000 A

straight elements (continued)

### Dimensions

with 1+1 window

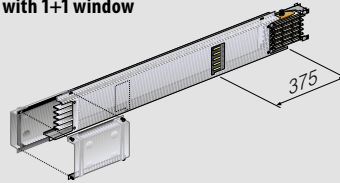

with 2+2 windows

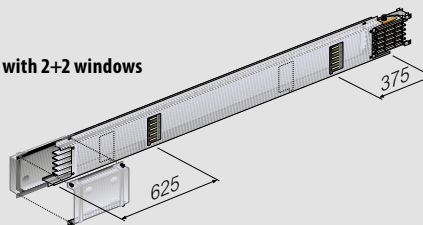

with 3+3 windows

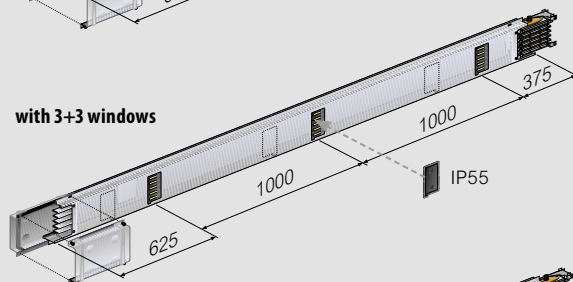

with 5 windows (on 1 side)

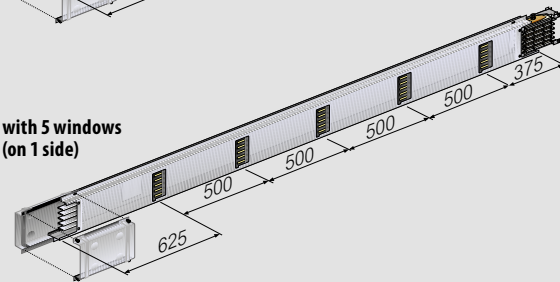

1+1 windows				2+2 windows			
Al	Weight (kg)	Cu	Weight (kg)	Al	Weight (kg)	Cu	Weight (kg)
5040 01 41	13.6	-	-	5040 01 51	13.6	-	-
5040 01 42	14.1	5540 01 42	16.5	5040 01 52	14.1	5540 01 52	16.5
5040 01 43	14.9	5540 01 43	17.7	5040 01 53	14.9	5540 01 53	17.7
5040 01 44	23.3	5540 01 44	22.0	5040 01 54	23.3	5540 01 54	22.0
5040 01 48	25.2	-	-	5040 01 58	25.2	-	-
5040 01 45	26.9	5540 01 45	34.3	5040 01 55	26.9	5540 01 55	34.3
5040 01 46	28.0	5540 01 46	42.2	5040 01 56	28.0	5540 01 56	42.2
5040 01 47	30.1	5540 01 47	47.8	5040 01 57	30.1	5540 01 57	47.8

3+3 windows				5 windows on 1 side			
Al	Weight (kg)	Cu	Weight (kg)	Al	Weight (kg)	Cu	Weight (kg)
5040 01 01	19.9	-	-	5040 02 51	19.9	-	-
5040 01 02	20.9	5540 01 02	25.7	5040 02 52	20.9	5540 02 52	25.7
5040 01 03	22.8	5540 01 03	28.1	5040 02 53	22.8	5540 02 53	28.1
5040 01 04	33.8	5540 01 04	36.9	5040 02 54	33.8	5540 02 54	36.9
5040 01 08	37.5	-	-	5040 02 58	37.5	-	-
5040 01 05	41.7	5540 01 05	56.0	5040 02 55	41.7	5540 02 55	56.0
5040 01 06	44.3	5540 01 06	72.1	5040 02 56	44.3	5540 02 56	72.1
5040 01 07	46.8	5540 01 07	83.7	5040 02 57	46.8	5540 02 57	83.7

0 - 4 Conductors, galvanized (MR)  
 1 - 5 Conductors, galvanized (MRf)  
 2 - 4 Conductors, painted (MR-P)  
 3 - 5 Conductors, painted (MRf-P)

# MEDIUM RATING (MR) 160 - 1000A

indoor applications - Data Center straight elements (IP40)



Pack	Cat.Nos	Straight elements			
	Al	In (A)	L (mm)	N° windows (STEP 600 mm)	Weight (kg)
1	50400261-1200	160	1200	2+2	6,7
1	50400262-1200	250			7,4
1	50400263-1200	315			8,2
1	50400264-1200	400			12,6
1	50400268-1200	500			14,1
1	50400265-1200	630			15,7
1	50400266-1200	800			16,8
1	50400267-1200	1000			17,8
1	50400261-2400	160	2400	4+4	15,6
1	50400262-2400	250			17,1
1	50400263-2400	315			18,7
1	50400264-2400	400			27,5
1	50400268-2400	500			30,4
1	50400265-2400	630			33,8
1	50400266-2400	800			35,9
1	50400267-2400	1000			37,9
1	50400261	160	3000	5+5	20,1
1	50400262	250			22,0
1	50400263	315			23,9
1	50400264	400			34,9
1	50400268	500			38,6
1	50400265	630			42,8
1	50400266	800			45,4
1	50400267	1000			47,9
1	50400271-1600	160	1600	2+2	9,3
1	50400272-1600	250			10,4
1	50400273-1600	315			11,4
1	50400274-1600	400			17,2
1	50400278-1600	500			19,2
1	50400275-1600	630			21,4
1	50400276-1600	800			22,8
1	50400277-1600	1000			24,2
1	50400271-2400	160	2400	3+3	15,6
1	50400272-2400	250			17,1
1	50400273-2400	315			18,7
1	50400274-2400	400			27,5
1	50400278-2400	500			30,4
1	50400275-2400	630			33,8
1	50400276-2400	800			35,9
1	50400277-2400	1000			37,9

For the version with copper conductors contact Legrand

The straight elements for data centers are available with IP40 protection, more than enough for the installation environment inside "white rooms".

For the bracket look at dedicated page 68-69.

Pack	Cat.Nos	End cover IP40	
			Weight (kg)
1	50403103	MR end cover IP40 LOW	0,77
1	50403104	MR end cover IP40 HIGH	1,13

LOW profile: from 160A to 315A Al from 250A to 400A Cu HIGH profile: from 400A to 1000A Al from 630A to 1000A Cu

For the FEED UNIT look at dedicated page 58.

		Plastic boxes for MR Data Center (for Low Profile)		
		Range of boxes with reduced hooks.		
		Ratings: 160-250-315 A (Al) 250-315-400 A (Cu)		
		For HIGH Profile is not necessary to use the boxes with reduced hooks		
	In (A)	Description	N° of modules	
1	50414071-B30 2A	Blind, long, empty Box with DIN rail	12	
1	55055086-B30 4D	63 Box with DIN rail	8	
1	55055088-B30 4E		11	
1	55055055-B30 4B	Box empty	-	
1	55055056-B30 4D	125 Box with DIN rail	8	
1	55055066-B30 4C		4	
1	55055068-B30 4E		11	
1	50404024-B30 4C	160 Box with DIN rail	4	

Metal boxes (type 6P) with reduced hooks for Data Center, where the code not change (without extension -B30), is possible to install on Low profile ranges (Al and Cu)

### TYPE OF BOXES (WITHOUT REDUCED HOOKS) USED

Type: 1 - 32A  
2 - 32A  
4 - 63A/160A (B-C-D-E)  
6 - 63A/160A (P)

Is possible use this type of boxes without to guarantee to use all available outlets on straight elements in the same time

In the straight elements the step of single outlets dedicated at racks are 600mm or 800mm which ensures the installation of the boxes on central position in every cabinet contains different "RACKS", allowing, in the case of failure, to identify and intervene rapidly on the no-functioning box. On the next page there is an example of connection between the cabinet containing rack and straight elements.

- 0 - 4 Conductors, galvanized (MR)
- 1 - 5 Conductors, galvanized (MRf)
- 2 - 4 Conductors, painted (MR-P)
- 3 - 5 Conductors, painted (MRf-P)

# MEDIUM RATING (MR) 160 - 1000A

## Data Center straight elements and fire barrier S120

### ■ Dimensions

Elements with windows step 600 (on both sides)  
3 m

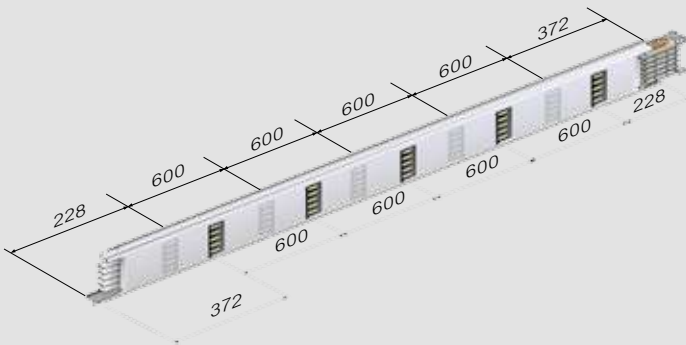

Elements with windows step 800 (on both sides)  
2,4 m

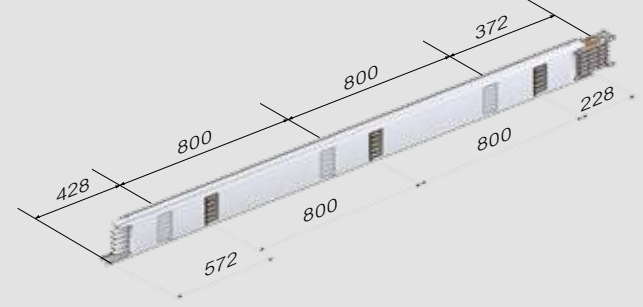

### Example of connection between the cabinet containing 600 mm rack and busbar

Straight element length 3 m with 5 + 5 windows step 600 mm  
Line A: FRONT side is dedicated to supply of power, BACK side for the backup.  
Line B: FRONT and BACK side are dedicated for backup.

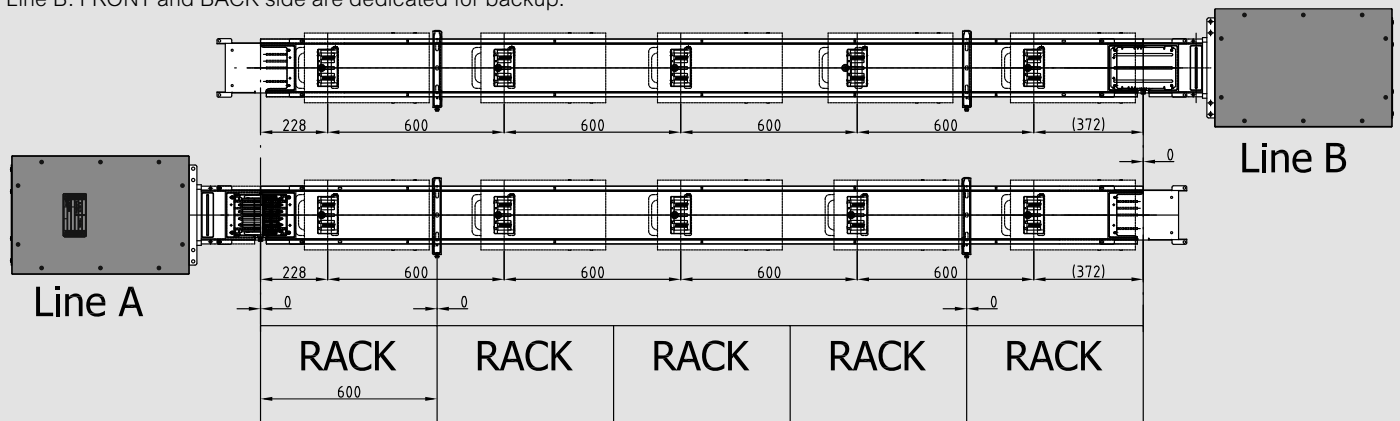

### ■ Fire barrier S120



### ■ Dimensions

#### Fire barrier S120

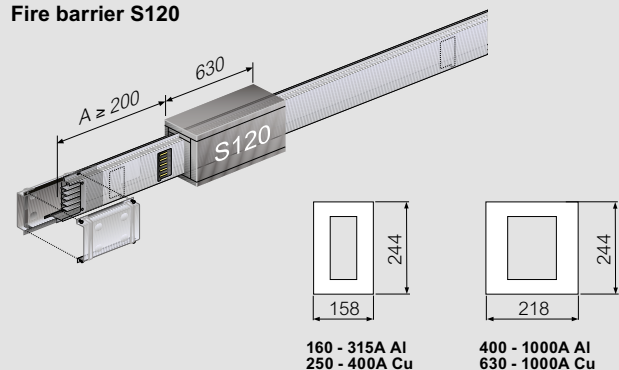

Pack	Item				Fire barrier S120	In (A)
	Al		Cu			
	External	Internal	External	Internal		
1	554EFB01	554IFB01	-	-		160
1	554EFB01	554IFB02	554EFB01	554IFB01		250
1	554EFB01	554IFB03	554EFB01	554IFB02		315
1	554EFB02	554IFB04	554EFB01	554IFB05		400
1	554EFB02	554IFB06	-	-		500
1	554EFB02	554IFB07	554EFB02	554IFB04		630
1	554EFB02	554IFB08	554EFB02	554IFB06		800
1	554EFB02	554IFB09	554EFB02	554IFB07		1000

	Conductors	Code
MR	4	-----0-
MRf	5	-----1-

When ordering, specify the dimension A = ..... mm of the element that will be equipped with the fire barrier

In your Purchase Order please specify the required position of the internal fire barrier. Take the measurement as shown in the Figure. The internal fire barrier is 630 mm long.

# Medium Rating (MR)

elbows



Pack	Cat.Nos				In (A)	Type
	Standard (300+300mm)		At measure * see dimension (mm) MIN & MAX			
	Al	Cu	Al	Cu		
1	50400301	-	50400321	-	160	Horizontal Right
1	50400302	55400302	50400322	55400322	250	
1	50400303	55400303	50400323	55400323	315	
1	50400304	55400304	50400324	55400324	400	
1	50400308	-	50400328	-	500	
1	50400305	55400305	50400325	55400325	630	
1	50400306	55400306	50400326	55400326	800	
1	50400307	55400307	50400327	55400327	1000	
1	50400311	-	50400331	-	160	Horizontal Left
1	50400312	55400312	50400332	55400332	250	
1	50400313	55400313	50400333	55400333	315	
1	50400314	55400314	50400334	55400334	400	
1	50400318	-	50400338	-	500	
1	50400315	55400315	50400335	55400335	630	
1	50400316	55400316	50400336	55400336	800	
1	50400317	55400317	50400337	55400337	1000	
1	50400401	-	50400421	-	160	Vertical Right
1	50400402	55400402	50400422	55400422	250	
1	50400403	55400403	50400423	55400423	315	
1	50400404	55400404	50400424	55400424	400	
1	50400408	-	50400428	-	500	
1	50400405	55400405	50400425	55400425	630	
1	50400406	55400406	50400426	55400426	800	
1	50400407	55400407	50400427	55400427	1000	
1	50400411	-	50400431	-	160	Vertical Left
1	50400412	55400412	50400432	55400432	250	
1	50400413	55400413	50400433	55400433	315	
1	50400414	55400414	50400434	55400434	400	
1	50400418	-	50400438	-	500	
1	50400415	55400415	50400435	55400435	630	
1	50400416	55400416	50400436	55400436	800	
1	50400417	55400417	50400437	55400437	1000	

- 0 - 4 Conductors, galvanized (MR)
- 1 - 5 Conductors, galvanized (MRf)
- 2 - 4 Conductors, painted (MR-P)
- 3 - 5 Conductors, painted (MRf-P)

# Medium Rating (MR)

elbows

## Dimensions

### Horizontal Elbow

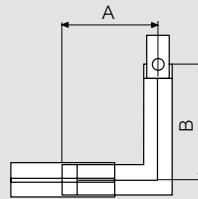

Dimension (mm)	
A	B
MIN 250	MAX 899
MIN 250	MAX 899

### Vertical Elbow

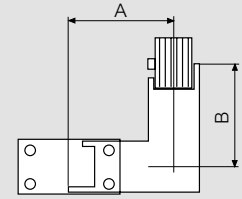

Dimension (mm)	
A	B
MIN 300	MAX 899
MIN 300	MAX 899

Elbows standard:  
A = 300 mm  
B = 300 mm

In (A)	Al Weight (kg)	Cu Weight (kg)
160	8.1	-
250	8.2	9.2
315	8.4	9.6
400	14.5	11.0
500	14.9	-
630	15.4	18.7
800	15.7	21.4
1000	16.0	23.3

## Type of elbows

### Horizontal elbow

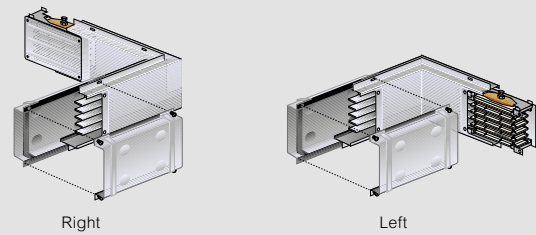

### Vertical elbow

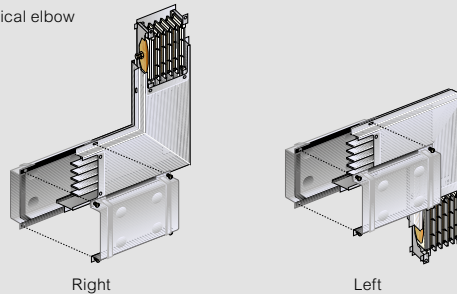

\* For all the non standard angles, it is possible to have only one of the two sides in size exceeding 600 mm. For example, when ordering an horizontal angle with size A=650 mm, the B size will have to be ≤ 600 mm

In your purchase order please specify the required length (see page: How to take measurements).

# Medium Rating (MR)

## elbows (continued)

### Type of double elbows on request

Double horizontal elbow

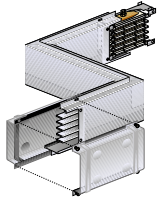

Right + Left



Left + Right

Double vertical elbow

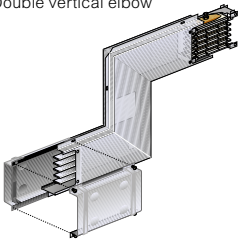

Right + Left

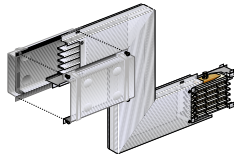

Left + Right

Double horizontal elbow + vertical elbow



Right + Right



Right + Left

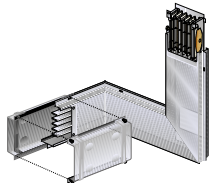

Left + Right

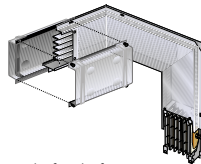

Left + Left

Double vertical elbow + horizontal elbow



Right + Right

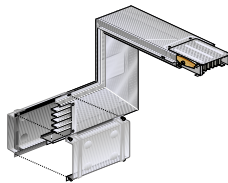

Right + Left



Left + Right

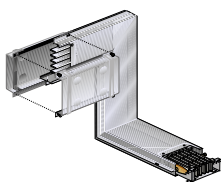

Left + Left

### ■ Dimensions

#### Double Horizontal

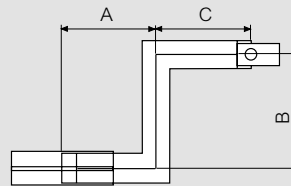

Dimension (mm)

	MIN	MAX
A	250	899
B	100	599
C	250	899

In (A)	Weight (kg) for Double Horizontal Double Vertical	
	Al	Cu
160	10.29	-
250	10.55	12.23
315	11.06	12.97
400	18.37	15.72
500	19.50	-
630	20.55	25.77
800	21.20	30.88
1000	21.80	34.55

#### Double Vertical

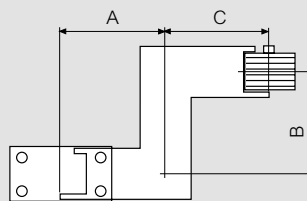

Dimension (mm)

	MIN	MAX
A	300	899
B	100	599
C	300	899

#### Double Horizontal + Vertical

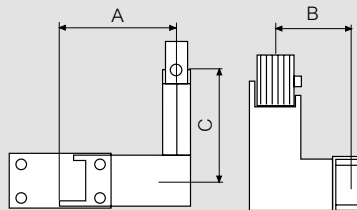

Dimension (mm)

	MIN	MAX
A	250	899
B	200	599
C	300	899

In (A)	Weight (kg) for Double Horizontal+Vertical and Double Vertical+Horizontal	
	Al	Cu
160	10.29	-
250	10.55	12.23
315	11.06	12.97
400	18.37	15.72
500	19.50	-
630	20.55	25.77
800	21.20	30.88
1000	21.80	34.55

#### Double Vertical + Horizontal

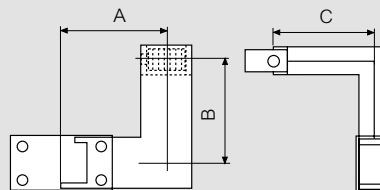

Dimension (mm)

	MIN	MAX
A	300	899
B	200	599
C	250	899

\* For all the non standard elbow, it is possible to have only one of the three sides in size exceeding 600 mm. For example, when ordering a double horizontal angle with size A=650 mm, the B and C size will have to be  $\leq 600$  mm

Special dimensions are available on request, please contact Legrand

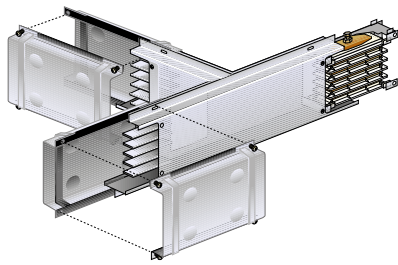

## Medium Rating (MR)

horizontal "T" elements

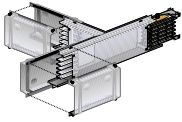

50400704

The various versions allow any type of path and are different from the monoblocs position and branch point  
Special dimensions are available on request

Pack	Cat.Nos		In (A)	Type
	Al	Cu		
	<b>Horizontal standard T elements (300+300+300 mm)</b>			
1	5040 07 01	-	160	 Right 1
1	5040 07 02	5540 07 02	250	
1	5040 07 03	5540 07 03	315	
1	5040 07 04	5540 07 04	400	
1	5040 07 08	-	500	
1	5040 07 05	5540 07 05	630	
1	5040 07 07	5540 07 06	800	
1	5040 07 07	5540 07 07	1000	
1	5040 07 11	-	160	
1	5040 07 12	5540 07 12	250	
1	5040 07 13	5540 07 13	315	
1	5040 07 14	5540 07 14	400	
1	5040 07 18	-	500	
1	5040 07 15	5540 07 15	630	
1	5040 07 17	5540 07 16	800	
1	5040 07 17	5540 07 17	1000	
1	5040 07 21	-	160	 Left 1
1	5040 07 22	5540 07 22	250	
1	5040 07 23	5540 07 23	315	
1	5040 07 24	5540 07 24	400	
1	5040 07 28	-	500	
1	5040 07 25	5540 07 25	630	
1	5040 07 27	5540 07 26	800	
1	5040 07 27	5540 07 27	1000	
1	5040 07 31	-	160	 Left 2
1	5040 07 32	5540 07 32	250	
1	5040 07 33	5540 07 33	315	
1	5040 07 34	5540 07 34	400	
1	5040 07 38	-	500	
1	5040 07 35	5540 07 35	630	
1	5040 07 37	5540 07 36	800	
1	5040 07 37	5540 07 37	1000	

0 - 4 Conductors, galvanized (MR)  
1 - 5 Conductors, galvanized (MRf)  
2 - 4 Conductors, painted (MR-P)  
3 - 5 Conductors, painted (MRf-P)

## Medium Rating (MR)

horizontal "T" elements

### ■ Dimensions

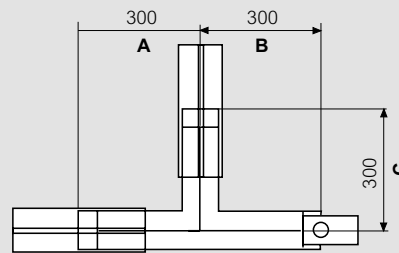

Dimension (mm)	Min.	Max.
	A	300
B	300	899
C	300	899

In (A)	Weight (kg)	
	Al	Cu
160	11.2	-
250	11.4	12.8
315	11.8	13.4
400	18.4	15.7
500	19.5	-
630	20.0	24.4
800	20.5	28.5
1000	20.5	31.3

\* For non standard T elements, it is possible to have only one of the three sides in size exceeding 600 mm. For example, when ordering an horizontal T element with size A=650 mm, B and C sizes will have to be ≤ 600 mm

For horizontal "T" special dimensions (not standard) and vertical "T" elements, please contact Legrand

## Medium Rating (MR)

### cross elements

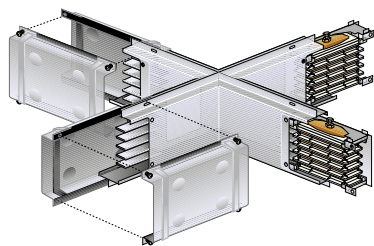

50403008

Pack	Cat.Nos		In (A)
	Al	Cu	
1	5040 30 01	-	160
1	5040 30 02	5540 30 02	250
1	5040 30 03	5540 30 03	315
1	5040 30 04	5540 30 04	400
1	5040 30 08	-	500
1	5040 30 05	5540 30 05	630
1	5040 30 06	5540 30 06	800
1	5040 30 07	5540 30 07	1000

**Cross standard elements  
(300+300+300+300 mm)**

Special dimensions (not standard) are available on request, please contact Legrand

- 0 - 4 Conductors, galvanized (MR)
- 1 - 5 Conductors, galvanized (MRf)
- 2 - 4 Conductors, painted (MR-P)
- 3 - 5 Conductors, painted (MRf-P)

## Medium Rating (MR)

### cross elements

#### Dimensions

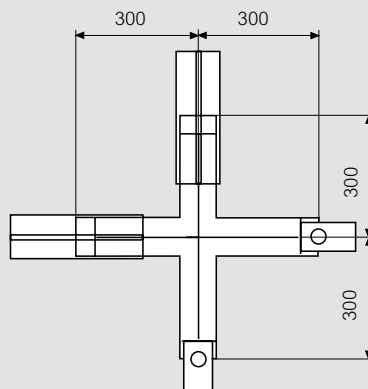

In (A)	Weight (kg)	
	Al	Cu
160	15.5	-
250	15.7	17.6
315	16.1	18.4
400	27.5	21.1
500	29.1	-
630	29.3	35.2
800	29.5	40.2
1000	29.9	43.7

## Medium Rating (MR)

### feed units

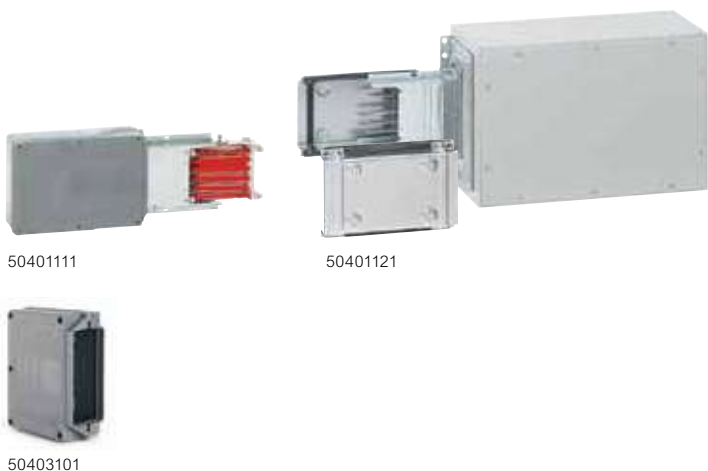

Pack	Cat.Nos		Feed units		
	Al	Cu	In (A)	Description	Type
1	50401101	-	160		Right
1	50401102	55401102	250		
1	50401111	-	160		Left
1	50401112	55401112	250		
1	50401121	-	160		Right
1	50401122	55401122	250		
1	50401123	55401123	315		
1	50401124	55401124	400		
1	50401128	-	500		
1	50401125	55401125	630		
1	50401126	55401126	800		
1	50401127	55401127	1000		Left
1	50401131	-	160		
1	50401132	55401132	250		
1	50401133	55401133	315		
1	50401134	55401134	400		
1	50401138	-	500		
1	50401135	55401135	630		
1	50401136	55401136	800		
1	50401137	55401137	1000		
1	50401201	-	160		
1	50401202	55401202	250		
1	50401203	55401203	315		
1	50401204	55401204	400		
1	50401208	-	500		

The box is shipped with its body part positioned on the inside to reduce its overall dimensions. Take it out and screw it into the position shown here. The dimensions of the bars and holes are described in the corresponding rating of the Board/Transformer on the next page.

End cover IP55*		
1	50403101	For bars in Cu of 250-315-400 A and Al 160-250-315 A
1	50403102	For bars in Cu of 630-800-1000 A and Al 400-500-630-800-1000 A

\*Suitable for all MR versions.

Ensures the closure and the IP55 degree of protection (EN 60529).

## Medium Rating (MR)

### feed units

#### Dimensions

##### Plastic Feed unit

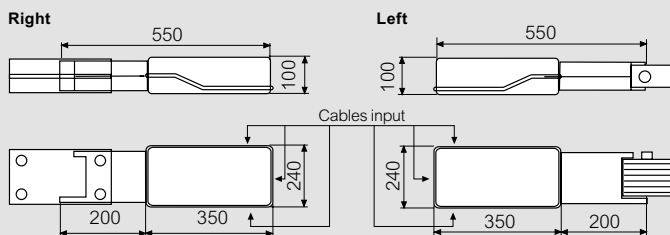

Item code Al	Weight (kg)	In (A)	Item code Cu	Weight (kg)	Cable connection: max. sect. (3x120mm <sup>2</sup> + 1x70mm <sup>2</sup> ) or (3x150mm <sup>2</sup> ) max PG 48
5040 11 01	5.70	160	-	-	
5040 11 02	5.85	250	5540 11 02	6.10	
5040 11 11	6.80	160	-	-	
5040 11 12	6.85	250	5540 11 12	7.20	

##### Metal Feed unit

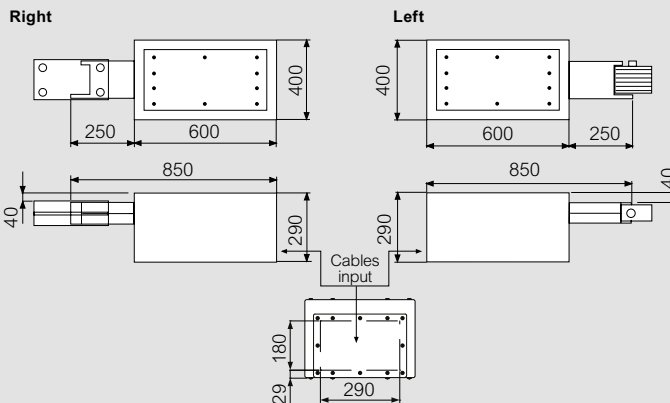

Upon request, the feed units are available with AC23 switch disconnector installed

Item code Al	Weight (kg)	In (A)	Item code Cu	Weight (kg)
5040 11 21	16.64	160	-	-
5040 11 22	16.76	250	5540 11 22	17.37
5040 11 23	17.03	315	5540 11 23	17.70
5040 11 24	18.32	400	5540 11 24	18.88
5040 11 28	20.00	500	-	-
5040 11 25	19.43	630	5540 11 25	21.17
5040 11 26	19.80	800	5540 11 26	23.30
5040 11 27	20.20	1000	5540 11 27	24.83
5040 11 31	17.74	160	-	-
5040 11 32	17.76	250	5540 11 32	18.47
5040 11 33	17.83	315	5540 11 33	18.70
5040 11 34	23.22	400	5540 11 34	19.58
5040 11 38	23.20	500	-	-
5040 11 35	23.63	630	5540 11 35	26.07
5040 11 36	23.70	800	5540 11 36	27.80
5040 11 37	24.00	1000	5540 11 37	29.03

##### Intermediate Metal Feed unit

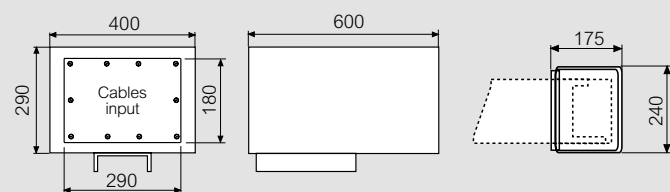

Item code Al	Weight (kg)	Item code Cu
5040 12 01	17.3	-
5040 12 02	18.4	5540 12 02
5040 12 03	17.0	5540 12 03
5040 12 04	22.06	5540 12 04
5040 12 08	22.65	-
5040 12 05	23.24	5540 12 05
5040 12 06	23.02	5540 12 06
5040 12 07	24.70	5540 12 07

Used to power a busbar from any intermediate point on the connection between two elements. The intermediate end feed unit is also used for reducing the voltage drop of the line

## Medium Rating (MR)

feed units for electric board/ transformer



50401001

Feed unit for direct connection of the busbar to an electric board or to the LV terminals of a distribution transformer.

Pack	Cat.Nos		Feed units for electric board/ transformer		
	Al	Cu	In (A)	Description	Type
1	50401001	-	160	 electric board/ transformer	Right
1	50401002	55401002	250		
1	50401003	55401003	315		
1	50401004	55401004	400		
1	50401008	-	500		
1	50401005	55401005	630		
1	50401006	55401006	800		
1	50401007	55401007	1000		
1	50401011	-	160	 	Left
1	50401012	55401012	250		
1	50401013	55401013	315		
1	50401014	55401014	400		
1	50401018	-	500		
1	50401015	55401015	630		
1	50401016	55401016	800		
1	50401017	55401017	1000		

- 0 - 4 Conductors, galvanized (MR)
- 1 - 5 Conductors, galvanized (MRf)
- 2 - 4 Conductors, painted (MR-P)
- 3 - 5 Conductors, painted (MRf-P)

## Medium Rating (MR)

feed units for electric board/ transformer

### Dimensions

#### Feed unit for electric board/ transformer

##### Right

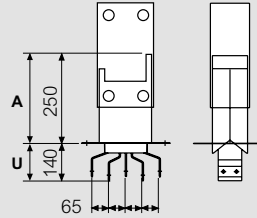

Dimension (mm)	
	Min. Max.
A	250 849
U	140 200

##### Left

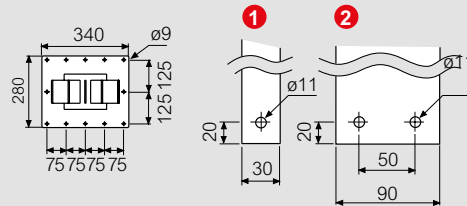
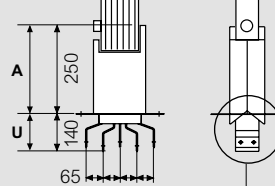

Item code Al	Weight (kg)	In (A)	Item code Cu	Weight (kg)
5040 10 01	4.9	160	-	-
5040 10 02	5.1	250	5540 10 02	5.7
5040 10 03	5.3	315	5540 10 03	6.0
5040 10 04	6.4	400	5540 10 04	9.2
5040 10 08	6.9	500	-	-
5040 10 05	7.5	630	5540 10 05	9.3
5040 10 06	7.9	800	5540 10 06	11.4
5040 10 07	8.3	1000	5540 10 07	12.9
5040 10 11	6.0	160	-	-
5040 10 12	6.1	250	5540 10 12	6.7
5040 10 13	6.2	315	5540 10 13	7.0
5040 10 14	11.3	400	5540 10 14	7.8
5040 10 18	11.4	500	-	-
5040 10 15	11.7	630	5540 10 15	14.2
5040 10 16	11.8	800	5540 10 16	15.9
5040 10 17	12.5	1000	5540 10 17	17.1

	Al	Cu
MR 1	160A	-
	250A	250 A
	315A	315 A
MR 2	400A	400 A
	500A	-
	630A	630 A
	800A	800 A
	1000A	1000 A

## Medium Rating (MR)

### tap-off boxes without disconnecting device



50414061



50414063



50414075

Pack	Cat.Nos	Tap-off boxes standard version	In (A)	N° of mod.
1	50414061	<b>1A</b> DIN rail	32	8
1	50414062	<b>1A</b> With fuse carrier 3xCH10 - 3x10.3x38 mm (fuses not included)		-
1	50414063	<b>1A</b> Transparent door and DIN Rail	16	4
1	50414064	<b>1A</b> Transparent door and DIN Rail		8
1	50414068*	<b>1B</b> With fuse carrier and DIN Rail - 3xD01 (fuses not included)	32	8
1	50414069*	<b>1A</b> With fuse carrier and DIN Rail - 3xD02 (fuses not included)		8
1	50414071	<b>2A</b> DIN rail	32	12
1	50414075	<b>2A</b> Transparent door and DIN Rail		12

\*Cable gland included

Pack	Cat.Nos	Tap-off boxes with internal cabling and transparent door	In (A)
1	50414111*	<b>1C</b> 3xD01 - Fuse carrier, transparent door, 3x16A german standard sockets (Schuko)	16 A
1	50414130	<b>1D</b> 4P 16A MCB curve B, transparent door and DIN Rail (4 modules)	16 A
1	50414128	<b>1D</b> 4P 16A MCB curve C, transparent door and DIN Rail (4 modules)	16 A
1	50414144	<b>1D</b> 4P 32A MCB curve C, transparent door and DIN Rail (4 modules)	32 A
1	50414122	<b>1E</b> 1P 16A MCB curve B, transparent door and DIN Rail (4 modules), 3x16A german standard sockets (Schuko)	16 A
1	50414121	<b>1E</b> 1P+N 16A MCB curve B, transparent door and DIN Rail (4 modules), 3x16A german standard sockets (Schuko)	16 A
1	50414221	<b>1F</b> Transparent door (4 modules), 3x16A german standard sockets (Schuko)	16 A
1	50414251	<b>1G</b> Set up for MCB (8 modules), 3x16A german standard sockets	16 A
1	50414162*	<b>2B</b> 3xD01 - Fuse carrier, transparent door, 1x16A CEE 3P+N+T socket	16 A
1	50414171*	<b>2B</b> 3xD01 - Fuse carrier, transparent door, 1x32A CEE 3P+N+T socket	32 A
1	50414161*	<b>2C</b> 3xD01 - Fuse carrier, transparent door and DIN rail, 2x16A CEE 3P+N+T sockets	16 A
1	50414185*	<b>2D</b> 4P 16A MCB curve C, transparent door and DIN Rail (8 modules), 2x16A CEE 3P+N+T sockets	16 A
1	50414181	<b>2E</b> 3x1P+N 16A MCB curve C, transparent door and DIN Rail (8 modules), 2x16A CEE 2P+T sockets	16 A
1	50414192	<b>2F</b> 4P 32A MCB curve C, transparent door and DIN Rail (8 modules), 1x32A CEE 3P+N+T socket	32 A
1	50414281	<b>2G</b> Set up for MCB (8 modules), 3x16A CEE 2P+T sockets	16 A
1	50414282	<b>2H</b> Set up for MCB (8 modules), 2x16A CEE 3P+N+T sockets	16 A
1	50414291	<b>2H</b> Set up for MCB (8 modules), 2x32A CEE 3P+N+T sockets	32 A

\*Fuses not included

# Medium Rating (MR)

## tap-off boxes without disconnecting device

### Dimensions

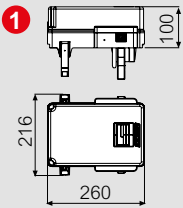

Version		
Item code	Fig.	Weight (kg)
5041 40 61	1A	1.60
5041 40 62	1A	1.75
5041 40 63	1A	1.70
5041 40 64	1A	1.70
5041 40 68	1B	2.07
5041 40 69	1A	2.15
5041 40 71	2A	1.90
5041 40 75	2A	2.05

The fuses are not included in the Tap-off boxes

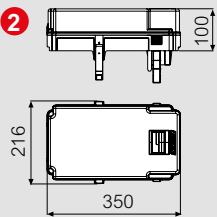

Power loss  
Version **1** 16W  
**2** 20W

MW: modules 17.5 mm

Energy withstand 400 x 10<sup>3</sup> A<sup>2</sup>s

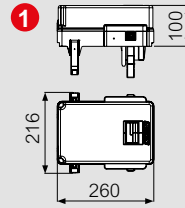

With internal cabling		
Item code	Fig.	Weight (kg)
5041 41 11	<b>1C</b>	2.29
5041 41 30	<b>1D</b>	2.29
5041 41 28	<b>1D</b>	2.29
5041 41 44	<b>1D</b>	2.36
5041 41 22	<b>1E</b>	2.13
5041 41 21	<b>1E</b>	2.10
5041 42 21	<b>1F</b>	1.83
5041 42 51	<b>1G</b>	1.94
5041 41 62	<b>2B</b>	2.60
5041 41 71	<b>2B</b>	2.79
5041 41 61	<b>2C</b>	2.96
5041 41 85	<b>2D</b>	3.23
5041 41 81	<b>2E</b>	3.05
5041 41 92	<b>2F</b>	3.06
5041 42 81	<b>2G</b>	2.55
5041 42 82	<b>2H</b>	2.49
5041 42 91	<b>2H</b>	2.49

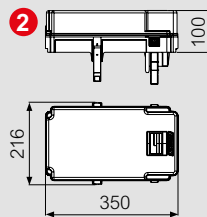

### Type of Tap-off boxes

<b>1A</b>  50414061	<b>1A</b>  50414062
<b>1A</b>  50414063	<b>1A</b>  50414064
<b>1B</b>  50414068*	<b>1A</b>  50414069*
<b>2A</b>  50414071	<b>2A</b>  50414075

### Type of Tap-off boxes

<b>1C</b>  50414111*	<b>1D</b>  50414130 - 50414128 - 50414144
<b>1E</b>  50414122 - 50414121	<b>1F</b>  50414221
<b>1G</b>  50414251	<b>2B</b>  50414162* - 50414171*
<b>2C</b>  50414161*	<b>2D</b>  50414185*
<b>2E</b>  50414181	<b>2F</b>  50414192
<b>2G</b>  50414281	<b>2H</b>  50414282 - 50414291

## Medium Rating (MR)

tap-off boxes with disconnecting device on the cover



55655051



55055086

Pack	Cat.Nos	Tap-off boxes with fuse carriers			
		These tap-off boxes are made from thermoplastic material strengthened with fibreglass (Type 3 and 4). They fit all MR versions and are provided with a set of three fuse carriers			
	<b>MR-MRf</b>	In (A)		Fuse carriers	
1	55655051	<b>3A</b> 32		CH10 (10.3x38)	
1	55055052	<b>4B</b> 63		CH22 (22x58)	
1	55055053	<b>4B</b> 125		NH0	
1	55055057	<b>4B</b> 125		NH00	
1	50404004	<b>4B</b> 160		NH0	
1	55655057	<b>5F</b> 250		NH1	metal
1	55655058*	<b>5F</b> 400		NH2	

Fuses not included

		Tap-off boxes for MCBs			
		All tap-off boxes with a transparent door are equipped with a DIN 50022 rail for modular devices. The transparent door of the box lets you access the equipment without opening the cover, thus isolating the load connected			
	<b>MR-MRf</b>	In (A)		N° of modules	
1	55055086	<b>4D</b> 63		8	
1	55055088	<b>4E</b> 63		11	
1	55055056	<b>4D</b> 125		8	
1	55055068	<b>4E</b> 125		11	
1	55055066	<b>4C</b> 125		4	
1	50404024	<b>4C</b> 160		4	
1	55055070*	<b>5G</b> 400		7	metal
1	55055071*	<b>5H</b> 400		11+11	

		Tap-off boxes empty version for MCBs			
		These boxes can be installed on the tap-off outlets of the MR. They can be plugged in and unplugged from the busbar only when the cover of the box is open i.e. when the tap-off is isolated. Boxes can be installed and disconnected from the energized busbar. The same box can be installed both on Aluminium and Copper conductors			
	<b>MR-MRf</b>				
1	55055055	<b>4B</b>	Empty In= 125A		
1	55655059*	<b>5F</b>	Empty In= 400A		metal

\* Neutral cross section 50%  
MCBs ( Miniature Circuit Breaker )

## Medium Rating (MR)

tap-off boxes with disconnecting device on the cover

### Type of Tap-off boxes

**3A**



55655051

**4B**

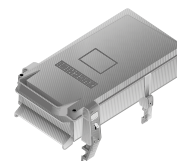

55055052 - 55055053 - 55055057 - 50404004 - 55055055

**4C**

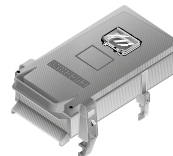

55055066 - 50404024

**4D**



55055056 - 55055086

**4E**



55055068 - 55055088

**5F** Metal box

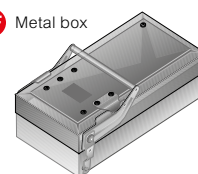

55655057 - 55655058 - 55655059

**5G** Metal box



55055070

**5H** Metal box

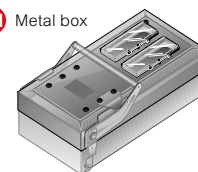

55055071

**NOTE:** All version of Tap-off boxes is possible to install in MR version (4 conductors) & MRf (5 conductors)

55655057, 55655058, 55055070. 55055071, 55655059 not usable on MR/MRf 1000 A AI

# Medium Rating (MR)

tap-off boxes with disconnecting device on the cover

## ■ Dimensions

### 3 32 A

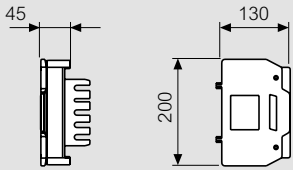

With fuse carriers		
Item code 5 conductors	Fig.	Weight (kg)
<b>MR - MRf</b>		
5565 50 51	3A	0.85
5505 50 52	4B	3.20
5505 50 53	4B	3.35
5505 50 57	4B	3.35
5040 40 04	4B	3.60
5565 50 57	5F	14.90
5565 50 58*	5F	15.80

Neutral cross section 50%

### 4 63- 160 A

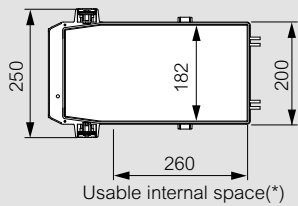
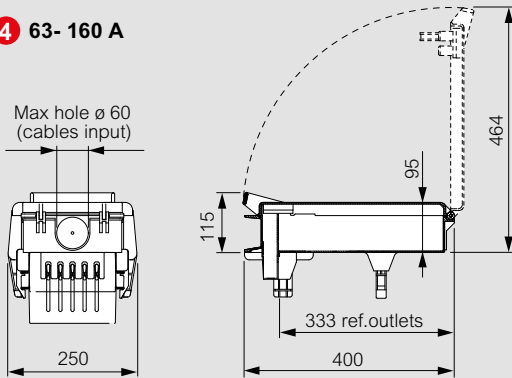

For mcb with transparent cover		
Item code 5 conductors	Fig.	Weight (kg)
<b>MR - MRf</b>		
5505 50 86	4D	3.20
5505 50 88	4E	3.60
5505 50 56	4D	3.20
5505 50 68	4E	3.60
5505 50 66	4C	3.00
5040 40 24	4C	3.60
5505 50 70*	5G	13.40
5505 50 71*	5H	15.30

Neutral cross section 50%

TERMINALS	
Phase / Neutral	Earth
M8	M5

### 5 250-400 A

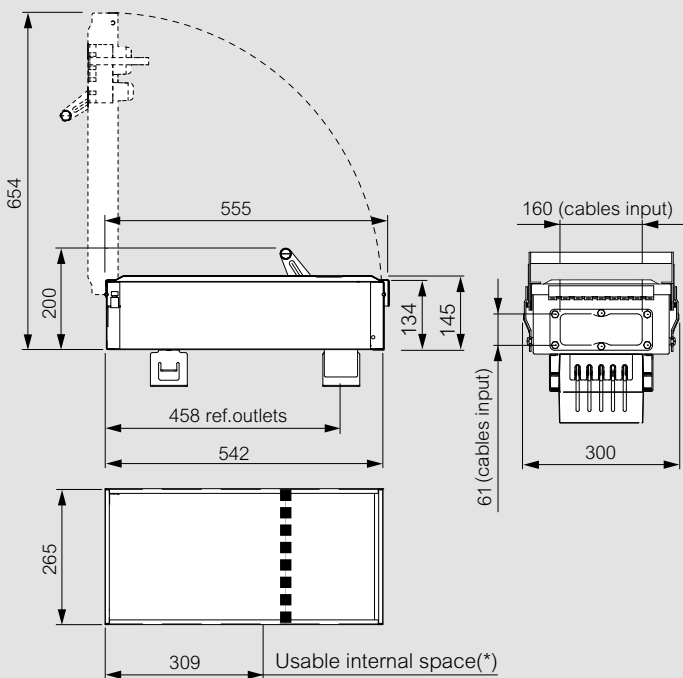

Empty for thermal magnetic CB		
Item code 5 conductors	Fig.	Weight (kg)
<b>MR - MRf</b>		
5505 50 55	4B	2.90
5565 50 59*	5F	14.30

Neutral cross section 50%

TERMINALS		
Phase	Neutral	Earth
M12	M8	M6

(\*) is referred at empty version

## Medium Rating (MR)

tap-off boxes with disconnecting device on the cover

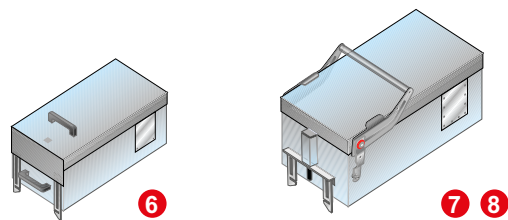

Pack	Cat.Nos	Tap-off boxes with fuse carrier		
		Tap-off box with galvanized and painted steel sheet structure. Metal boxes are suitable for heavy loads and are used to shield electric fields caused by flows of current		
	<b>MR-MRf</b>	<b>PE + FE</b>	In (A)	Fuse carrier
1	50414021	6P	63	CH22 (22x58)
1	50414022	6P	125	NH00
1	50414023	6P	160	NH00
1	50414024	7Q	250	NH2
1	50414026	8R	400	NH2
1	50414025	8R	630	NH3

Pack	Cat.Nos	Tap-off boxes with switch disconnecter (AC23)		
		Tap-off box with galvanized and painted steel sheet structure. Metal boxes are suitable for heavy loads and are used to shield electric fields caused by flows of current. These tap-off boxes are equipped with a switch disconnecter (AC23) and a fuse carrier. The disconnecter switch is operated through a rotary handle on the cover. Note: It is not possible to open, close, install or pull out the tap-off box if the switch is in "ON" position		
	<b>MR-MRf</b>	<b>PE + FE</b>	In (A)	Fuse carrier
1	50411601	6P	63	NH000
1	50411622	6P	125	NH00
1	50411623	6P	160	NH00
1	50411624	7Q	250	NH1
1	50411625	8R	400	NH2
1	50411646	8R	630	NH3

Pack	Cat.Nos	Tap-off boxes empty version		
		These boxes can be installed on the tap-off outlets of the MR. They can be plugged in and unplugged from the busbar only when the cover of the box is open i.e. when the tap-off is isolated. Boxes can be installed and disconnected from the energized busbar. The same box can be installed both on Aluminium and Copper conductors "PE+FE" tap-off boxes have separate terminals for the two earths whereas the "PE" boxes have parallel earths (casing and conductor). They can be customized with MCBs by various manufacturers. Boxes available with factory installed circuit breakers		
	<b>MR-MRf</b>	<b>PE + FE</b>	In (A)	
1	50414001	6P	63	
1	50414002	6P	125	
1	50414003	6P	160	
1	50414004	7Q	250	
1	50414005	8R	630	

Fuses not included  
**PE:** Protective earthing  
**FE:** Functional earthing

## Medium Rating (MR)

tap-off boxes with disconnecting device on the cover

### Type of Tap-off boxes

6P Metal box

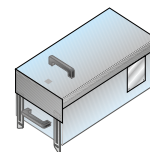

50414021 - 504140212 - 50414023 - 50414001 - 50414002  
 - 50414003 - 50411601 - 50411622 - 50411623

7Q Metal box

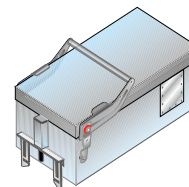

50414021 - 50414004 - 50411624

8R Metal box

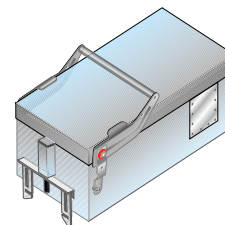

504140216 - 504140215 - 50414005 - 50411625 - 50411646

# Medium Rating (MR)

tap-off boxes with disconnecting device on the cover

## Dimensions

### 6P 63-160 A

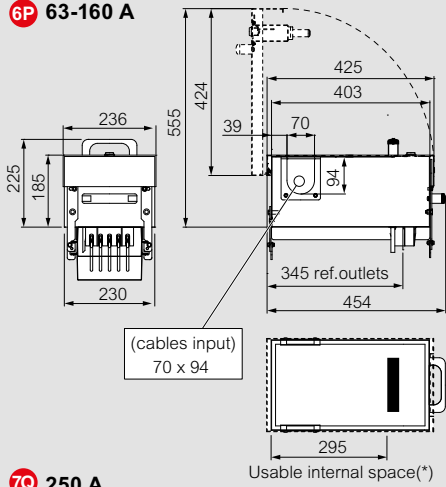

TERMINALS	
Phase/Neutral	Earth
M8	M6

refer to empty version

### 7Q 250 A

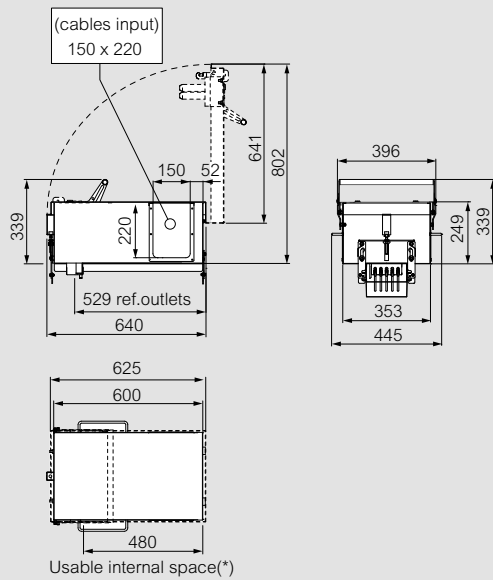

TERMINALS	
Phase/Neutral	Earth
M8	M8

refer to empty version

### 8R 400-630 A

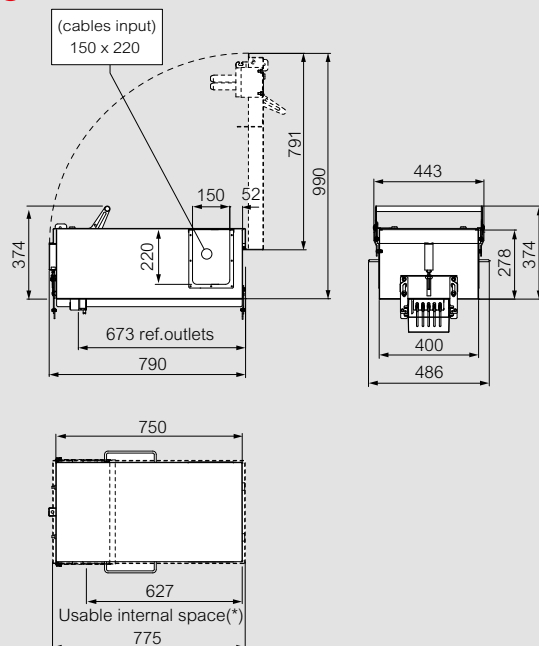

TERMINALS	
Phase/Neutral	Earth
M8	M12

refer to empty version

(\*) is referred at empty version

## Medium Rating (MR)

tap-off boxes bolt-on type

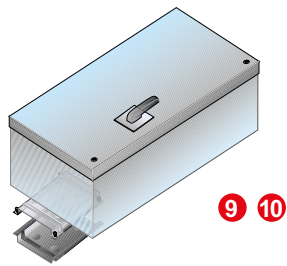

“Bolt-on” tap-off boxes  
They make use of the joint between straight  
elements as a connection for the junction  
As this connection affects live conductors, it can NOT be carried  
out when the line is energized - the line has to be isolated

Pack	Cat.Nos			Tap-off boxes with fuse carrier			
	630	800	1000	Rating (A)	Dimension	Circ. breaker	Fuse
				<b>Aluminium</b>			
1	50401801	50401802	50401803	630	9	AC23	NH3
1	-	50401804	50401805	800	10	AC23	NH4
1	-	-	50401806	1000	10	AC23	NH4
				<b>Copper</b>			
1	55401801	55401802	55401803	630	9	AC23	NH3
1	-	55401804	55401805	800	10	AC23	NH4
1	-	-	55401806	1000	10	AC23	NH4

### Cable entry plate (mm)

Type	9	10
	160 x 270	210 x 380

## Medium Rating (MR)

tap-off boxes bolt-on type

### Dimensions

#### 9 630 A

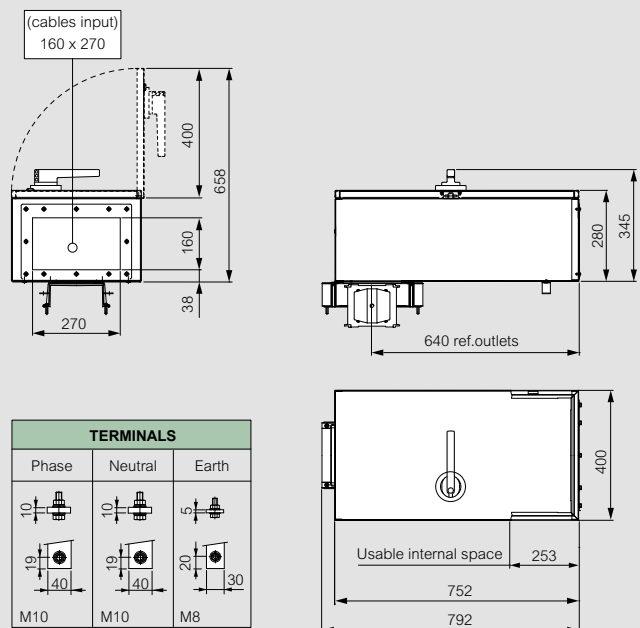

#### 10 800-1000 A

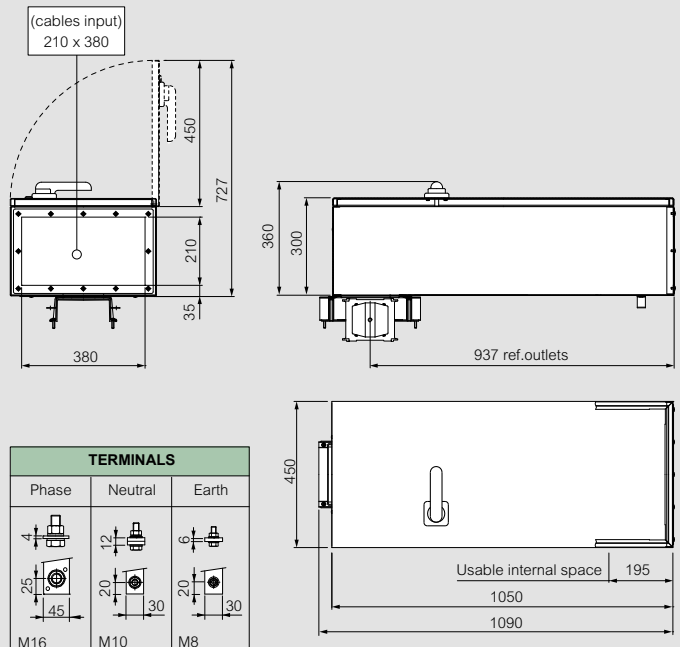

# Medium Rating (MR)

## tap-off boxes mounting

### Straight element with 3+3 windows

#### Edgewise

The numbers in the squares refer to the dimensions of the tap-off boxes. (see previous pages)

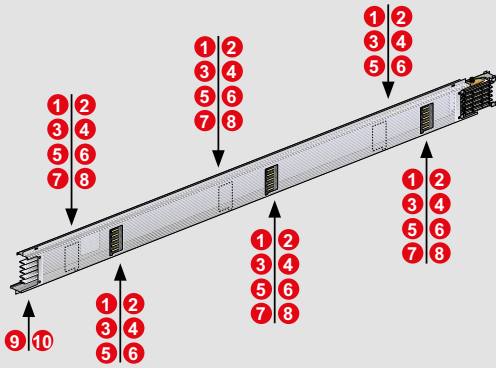

#### Riser mains

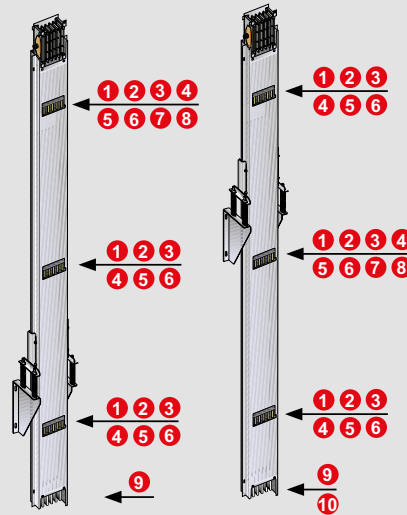

### Straight element with 5 windows

#### Edgewise

The numbers in the squares refer to the dimensions of the tap-off boxes. (see previous pages)

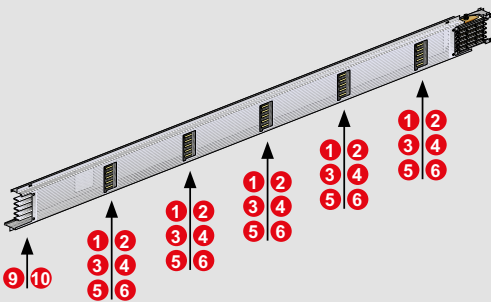

#### Riser mains

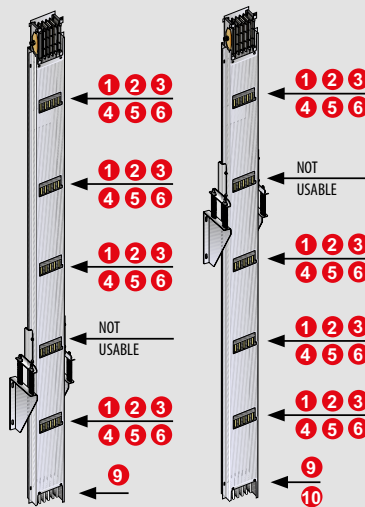

In elements with 5 windows, tap-off boxes with dimension 5 do not allow the possibility of installing other boxes on the next outlet

### Tap-off boxes mounting for Data Center application

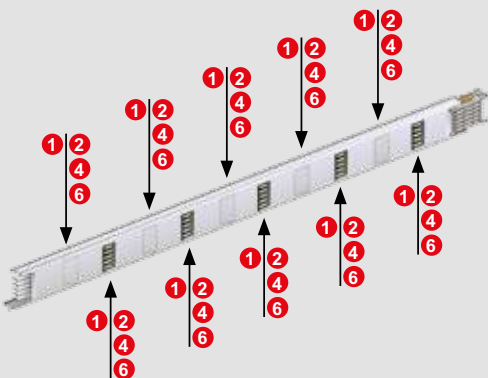

## Medium Rating (MR)

fastening device



Pack	Cat.Nos	Suspension brackets
10	50632001	<b>A</b> Suspension brackets for bars up to 400A Al: 160A-250A-315A Cu: 250A-315A-400A
10	50632003	<b>B</b> Suspension brackets for bars from 400A to 1000A Al: 400A-500A-630A-800A-1000A Cu: 630A-800A-1000A
10	50632205	<b>C</b> Wall spacer, required when the bracket needs to be fixed directly to the wall (40 mm)
2	50403711	<b>D</b> Suspension bracket for vertical elements, suitable <b>for riser mains up to 4 m and for weights up to 300 kg</b> It is to be used together with 50632001/3
2	50403712	<b>E</b> Suspension bracket with tie-rods for riser mains This bracket is used in vertical applications <b>Use one bracket every 300 Kg</b> (see weight busbars table)

Pack	Cat.Nos	Wall bracket holder
4	50632212	Adjustable arm both in height and in depth. The bracket holder can be combined with the MR - MS - TS brackets L= 0.45 m - max weight = 80 kg
4	50632213	Adjustable arm both in height and in depth. The bracket holder can be combined with the MR - MS - TS brackets L= 0.55 m - max weight= 68 kg
2	50632214	Adjustable arm both in height and in depth. The bracket holder can be combined with the MR - MS - TS brackets L= 0.75 m - max weight = 50 kg

## Medium Rating (MR)

fastening device

### Dimensions

#### Brackets

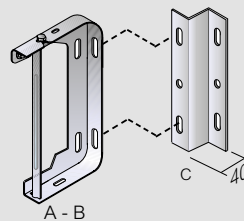

Item code	Fig.	Weight (kg)
5063 20 01	A	0.55
5063 20 03	B	0.60
5063 22 05	C	0.05

1 bracket for every 2 m of line

For more detail see page:  
How to take measurements

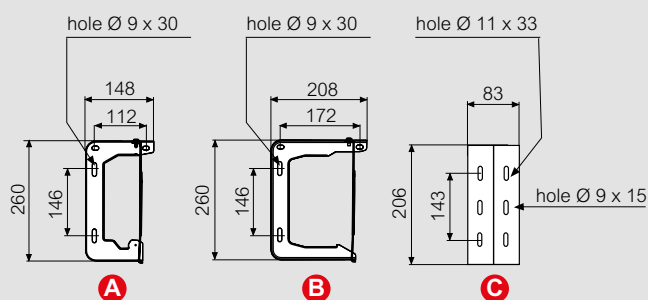

#### Brackets for vertical elements

Item code	Weight (kg)	
5040 37 11 <b>D</b>	1.05	1 bracket at the base of the riser mains max 4 m.
5040 37 12 <b>E</b>	1.20	1 bracket every 300 kg

#### Wall bracket holder

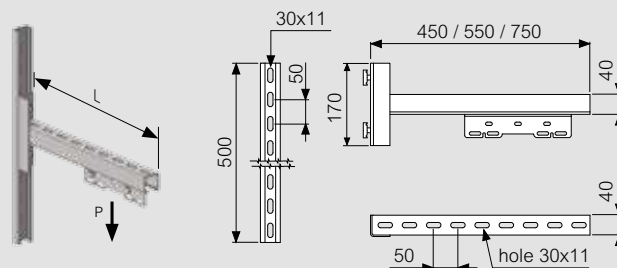

Item code	length	max weight	Weight (kg)
5063 22 12	L= 0.45 m	p max = 80 kg	2.80
5063 22 13	L= 0.55 m	p max = 68 kg	3.00
5063 22 14	L= 0.75 m	p max = 50 kg	3.50

# Medium Rating (MR)

fastening device



50403601

Pack	Cat.Nos	Fixing accessories
		Ceiling bracket holder with a base to be fixed to the ceiling and a drilled u-shaped section bar available in various lengths the section bar holes are suitable for being installed with the mr brackets
10	50632201	Ceiling flange
10	50632202	U-shaped bar L= 0.5 m
5	50632203	U-shaped bar L= 1 m
1	50632204	U-shaped bar L= 2 m
10	50632210	Bracket holder for beam fixing. This bracket holder has a bracket and two clamps that are hooked to the wings of the beam
		<b>Various accessories</b>
12	50403601	Outlet spare part Suitable for all MR versions

# Medium Rating (MR)

fastening device

## Dimensions

### Ceiling bracket holder

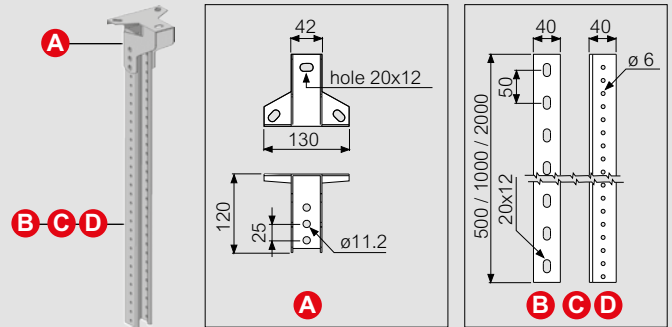

Item code	Description	Fig.	Weight (kg)
50632201	Ceiling flange	A	0.66
50632202	U-shaped bar L=0.5 m	B	1.0
50632203	U-shaped bar L=1 m	C	1.5
50632204	U-shaped bar L=2 m	D	2.0

### Beam bracket holder:

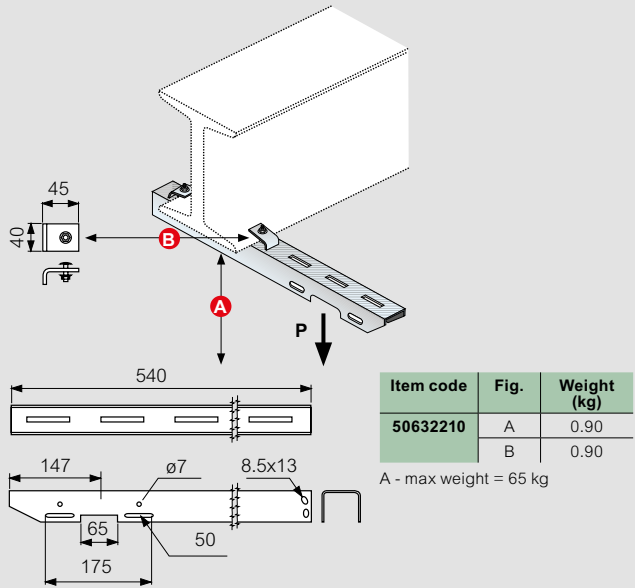

# Medium Rating (MR)

## technical informations

		MR - Al (3P+N+PE)								MR - Cu (3P+N+PE)						
		160	250	315	400	500	630	800	1000	250	315	400	630	800	1000	
Rated current	$I_n$ [A]									690	1000					
Operating voltage	$U_e$ (V)	1000								690	1000					
Insulation voltage	$U_i$ (V)	1000								690	1000					
Rated frequency	$f$ (Hz)	50/60														
Rated short-time current for three-phase fault (1 s)	$I_{cw}$ [kA] <sub>rms</sub>	15*	25*	25*	25	30	36	36	30	25*	25*	30*	36	36	36	
Allowable specific energy for three-phase fault	$I_t^2$ [MA <sup>2</sup> s]	23	63	63	625	900	1296	1296	900	63	63	90	1296	1296	1296	
Allowable peak current for three-phase fault	$I_{pk}$ [kA]	30	53	53	53	63	76	76	63	53	53	63	76	76	76	
Rated short-time current for single-phase fault Ph-N (1 s)	$I_{cw}$ [kA] <sub>rms</sub>	9*	15*	15*	15	18	22	22	18	15*	15*	18*	22	22	22	
Allowable peak current for single-phase fault	$I_{pk}$ [kA]	15	30	30	30	36	45	45	36	30	30	36	45	45	45	
Rated short-time current for single-phase fault Ph-PE (1 s)	$I_{cw}$ [kA] <sub>rms</sub>	9*	15*	15*	15	18	22	22	18	15*	15*	18*	22	22	22	
Rated peak current for single-phase fault Ph-PE	$I_{pk}$ [kA]	15	30	30	30	36	45	45	36	30	30	36	45	45	45	
Phase resistance at 20 °C	$R_{20}$ [mΩ/m]	0.492	0.328	0.197	0.120	0.077	0.060	0.052	0.037	0.237	0.180	0.096	0.061	0.040	0.032	
Phase resistance at thermal conditions ( $I_n$ ; 40°C)	$R_t$ [mΩ/m]	0.665	0.443	0.266	0.163	0.104	0.081	0.070	0.073	0.320	0.243	0.129	0.082	0.053	0.043	
Phase reactance at 50 Hz	$X$ [mΩ/m]	0.260	0.202	0.186	0.130	0.110	0.097	0.096	0.076	0.205	0.188	0.129	0.122	0.122	0.120	
Neutral resistance at 20 °C	$R_{n20}$ [mΩ/m]	0.492	0.328	0.197	0.120	0.077	0.060	0.052	0.037	0.237	0.180	0.096	0.061	0.040	0.032	
Neutral reactance at 50 Hz	$X_n$ [mΩ/m]	0.260	0.202	0.186	0.130	0.110	0.097	0.096	0.076	0.205	0.188	0.129	0.122	0.122	0.120	
Resistance of the protective conductor	$R_{PE}$ [mΩ/m]	0.341	0.341	0.341	0.283	0.283	0.283	0.283	0.283	0.336	0.336	0.336	0.279	0.279	0.279	
Reactance of the protective conductor at 50 Hz	$X_{PE}$ [mΩ/m]	0.220	0.220	0.220	0.180	0.180	0.180	0.180	0.180	0.220	0.220	0.220	0.180	0.180	0.180	
Resistance of the fault loop phase	$R_{Ph-Pe}$ fault loop [mΩ/m]	1.006	0.784	0.607	0.445	0.387	0.364	0.353	0.336	0.657	0.579	0.466	0.361	0.332	0.322	
Reactance of the fault loop phase-PE	$X_{RPh-Pe}$ fault loop [mΩ/m]	0.480	0.414	0.396	0.333	0.333	0.283	0.275	0.273	0.425	0.408	0.349	0.302	0.302	0.300	
Resistance of the fault loop phase-neutral	$R_{Ph-N}$ fault loop [mΩ/m]	1.157	0.771	0.463	0.283	0.181	0.141	0.121	0.093	0.558	0.423	0.225	0.143	0.093	0.074	
Reactance of the fault loop phase-neutral at 50 Hz	$X_{RPh-N}$ fault loop [mΩ/m]	0.480	0.422	0.406	0.310	0.290	0.277	0.276	0.186	0.425	0.408	0.349	0.302	0.302	0.300	
Voltage drop with distributed load referred to $\Delta V_{3f}$ (**)	$\Delta v$ [V/m/A] $10^{-3} \cos\varphi = 0.7$	0.564	0.394	0.276	0.179	0.131	0.109	0.102	0.090	0.321	0.263	0.158	0.125	0.108	0.100	
	$\Delta v$ [V/m/A] $10^{-3} \cos\varphi = 0.75$	0.581	0.404	0.279	0.180	0.130	0.108	0.100	0.088	0.326	0.265	0.158	0.123	0.105	0.096	
	$\Delta v$ [V/m/A] $10^{-3} \cos\varphi = 0.8$	0.596	0.412	0.281	0.180	0.129	0.107	0.098	0.085	0.329	0.266	0.157	0.120	0.100	0.092	
	$\Delta v$ [V/m/A] $10^{-3} \cos\varphi = 0.85$	0.608	0.418	0.281	0.179	0.127	0.104	0.095	0.082	0.329	0.264	0.154	0.116	0.095	0.086	
	$\Delta v$ [V/m/A] $10^{-3} \cos\varphi = 0.9$	0.616	0.422	0.277	0.176	0.122	0.100	0.091	0.077	0.327	0.260	0.149	0.110	0.088	0.079	
	$\Delta v$ [V/m/A] $10^{-3} \cos\varphi = 0.95$	0.617	0.419	0.269	0.169	0.115	0.093	0.083	0.069	0.319	0.251	0.141	0.101	0.077	0.068	
	$\Delta v$ [V/m/A] $10^{-3} \cos\varphi = 1$	0.576	0.384	0.230	0.141	0.090	0.070	0.060	0.046	0.277	0.210	0.112	0.071	0.046	0.037	
Joule effect losses at Rated current	$P$ [W/m]	51	83	79	78	78	97	134	160	60	72	62	98	103	128	
Fire load	[kWh/m]	1.3	1.3	1.3	1.8	1.8	1.8	1.8	1.8	1.3	1.3	1.3	1.8	1.8	1.8	
Weight	[kg/m]	7.4	7.7	8.4	10.7	12.3	13.8	14.7	15.9	9.3	10.2	13.3	18.2	23.9	27.9	
Outside dimensions of the busbar	$L \times H$ [mm]	75x196			135x196					75x196			135x196			
Protection degree	IP	55								55						
Mechanical resistance of the casings	IK	10								10						

(\*\*) **THREE-PHASE:**  $\Delta V_{3f} = \sqrt{3}/2 \times (R_t \cos\varphi + X \sin\varphi)$

$\Delta V_{3f}(I_n) = I \times L \times \Delta V_{3f}$ : (knowing the current and length of the line)

$\Delta V_{3f}(I_n)\% = (\Delta V_{3f}(I_n) / U_e) \times 100$  (%)

To calculate the  $\Delta V_{1f}$  (**SINGLE-PHASE**) on distributed load:

$\Delta V_{1f} = 1/2 \times (2R_t \cos\varphi + 2X \sin\varphi)$

$\Delta V_{1f}(I_n) = I \times L \times \Delta V_{1f}$ : (knowing the current and length of the line)

$\Delta V_{1f}(I_n)\% = (\Delta V_{1f}(I_n) / U_e) \times 100$  (%)

$I$  = operating current (A)

$L$  = length (m)

### Straight elements

The components and the features of the MR straight elements are:

- a casing made of galvanized steel used as protective earth (PE);
- overall busbar dimensions: 75x196 and 135x196;
- painted casing available on request; only MR/MRf 1000A Al is painted with RAL 7035;
- number of conductors: 4 with the same section (3P+N) with PE made from the casing or 5 when using MRfull (3P+N+PE), available in the aluminum or electrolytic copper version with 99.9% purity;
- conductors insulators are made by fiberglass reinforced plastic material, ensuring a V1 self-extinguishing degree (according to UL94), in compliance with the glow-wire test according to IEC 60695-2-10;
- tap-off outlets with a constant centre distance of 1 m on both sides of the busbar (3+3 windows every 3m), set up for being connected to plug-in type tap-off boxes; These outlets open and close automatically when inserting or pulling out a tap-off box;
- "monobloc" electric junction system made with tin plated aluminium for MR/MRf Al and copper for MR/MRf Cu system to connect conductors and PE in a fast and reliable way. The "monobloc" has shear-head bolts with a preset torque setting which ensure good, long-lasting electrical continuity

- all components and accessories of the MR line are IP55
- the whole busbar is fire retardant in compliance with the IEC 60332-3 standard

### Feed units

Allows you to electrically power the MR line through a cable line or directly connected to an electric distribution board. The 160 and 250A feed units have terminals for cables up to 150mm<sup>2</sup>; for higher ratings, the cable connection to the feed unit requires cable lugs to be fastened to the provided spreaders. The MR line can be provided with centre feed units or end feed units with a switch-disconnector which allows you to isolate the whole line for carrying out maintenance operations or layout changes, if required

### End cover

The end cover ensures the IP55 protection degree at the end of the line

### Fixing supports

In order to fix the line to the structure of the building, directly or with wall / ceiling / beam supports, it is necessary to use the bracket supports or vertical suspension supports

\* Values referred to 0.1 s

### ■ Tap-off boxes

Used for energizing three-phase loads from 16A up to 1000A; they can be divided into two big categories:

**1) Plug-in type tap-off boxes (from 16A up to 630A) with the following features:**

- Intervention under load possible up to 32A;
- disconnection device integrated into the cover of the boxes with a rating from 63A to 630A, ensuring automatic absence of electric current when the cover is opened;
- possibility of padlocking box cover in the open/disconnected position so that all maintenance operations of the loads connected to it can be carried out safely;
- the supplied PE contact (protective conductor) is the first to make an electrical connection when inserting the box into the outlet and it is the last to disconnect when pulling it out;
- all insulating plastic components are in compliance with the IEC 60695-2-1 glow-wire test and rated V2 self-extinguishing according to the UL94;
- standard IP55 degree of protection without using additional accessories;
- availability of boxes in the following versions:
  - with a set of three fuse carriers
  - with Lexic MCBs
  - with EEC sockets and Schuko sockets
  - with AC23 switch disconnecter and fuse carrier
  - for MCCBs.

**2) Boxes bolted onto the connection (from 630A to 1000A) which include the following features:**

- very easy, fast and reliable installation;
- high rated current;
- rigid connection to the busbar through the use of a monobloc junction similar to the straight element system;
- possibility of removing the boxes only when the busbar is not energized (isolated busbar);
- availability of boxes in the following versions:
  - AC23 switch disconnecter and fuse carrier
  - with MCCBs

Product fully in compliance with the following Standards: IEC 61439 -6. The busbar trunking systems are FIRE RETARDANT in compliance with IEC 20-22 (IEC 332-3: 1992).

Product suitable for these climates:

- IEC 60068 2-11: Environmental tests Part 2-11: Tests – Test Ka: Salt mist
- IEC 60068 2-30: Environmental tests Part 2-30: Tests – Test Db: Damp heat, cyclic(12 h + 12 h cycle)

### ■ Conversion table

	Conductors	Case	Item code	
MR	4	galvanized	---0---	
MRf	5	galvanized	---1---	
MR-P	4	painted	---2---	
MRf-P	5	painted	---3---	

### ■ Short circuit protection for LEGRAND's product ranges (In≤100A)

Legrand busbar trunking systems with a rated current lower than or equal to 100A are properly protected through an MCB (Modular Circuit Breaker) with a nominal current lower than or equal to that of the busbar. This protection is guaranteed up to the MCB breaking capacity

### ■ Temperature rating schedule according to the room temperature

Ambient temperature (°C)	15	20	25	30	35	40	45	50	55	60
Factor Kt	1.15	1.12	1.08	1.05	1.02	1	0.97	0.95	0.93	0.89

multiplier coefficient of rated current for room temperature values different from 40° C

## Medium Rating (MR)

operating instructions on how to design riser mains

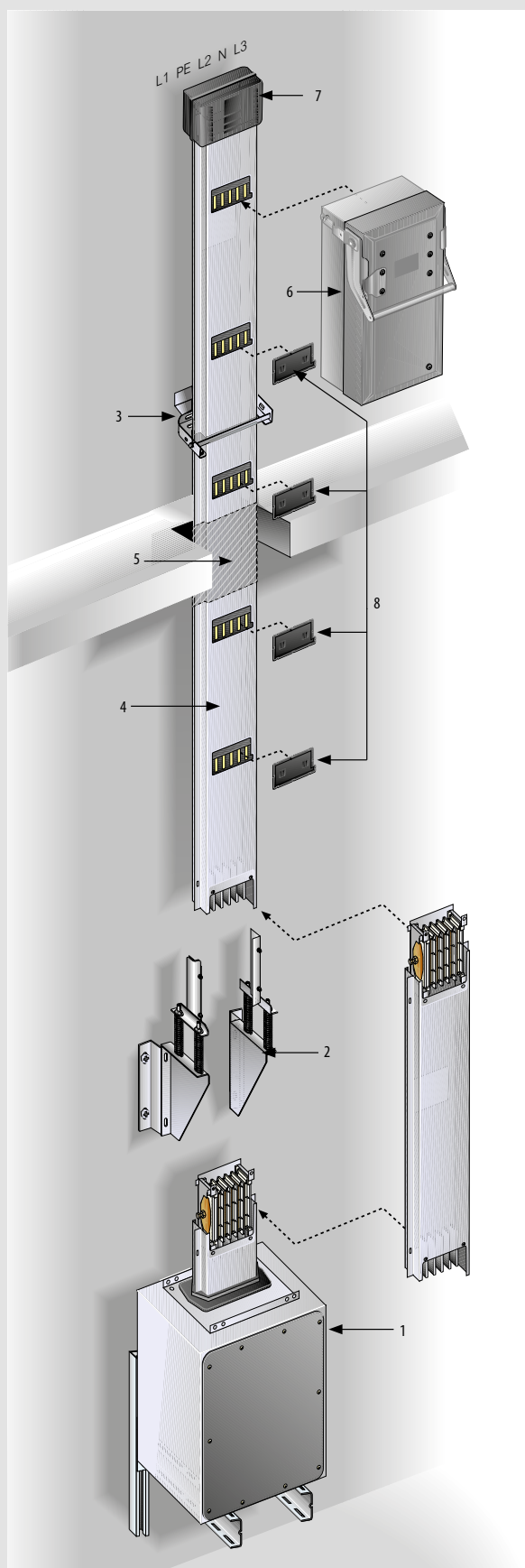

### General rules for design the rising mains

- 1 - Use a LH end feed unit. This allows the neutral bar to be positioned on the right side of the busbar, hence the cable exit of the tap-off boxes is located downwards
- 2 - Use one or more suspension brackets for the vertical elements, according to the weight of the whole rising mains. For risers that are shorter than 4 metres, fix to the base with code 50403711; when longer, use a suspension bracket code 50403712 every 300 kg of rising main
- 3 - Use a standard suspension bracket with a 40mm spacer every 2 metres of rising mains
- 4 - Use straight elements with 5 outlets on one side
- 5 - Use a straight element with fire barrier for each compartment floor. It is necessary to specify the position of the internal fire barrier before placing an order
- 6 - The tap-off boxes can be installed in the tap-off outlets and near the connection between the elements
- 7 - At the end of the riser mains, position the IP55 end cover. Before installing the end cover remove the monobloc located on the last element
- 8 - Put the outlet covers into the tap-off outlets in order to guarantee the IP55 degree of protection

For more installation details, please refer to the installation instructions

# Medium Rating (MR)

## how to take measurements

### ↓ DETERMINATION OF THE MEASUREMENTS FOR SPECIAL ELEMENTS

#### ■ Straight elements

Always take measurements on the long side on the metal casing as shown in the figure. For simplicity's sake, it will be referred to as "long casing"



The length of the straight elements can range from 600 mm to 3000 mm

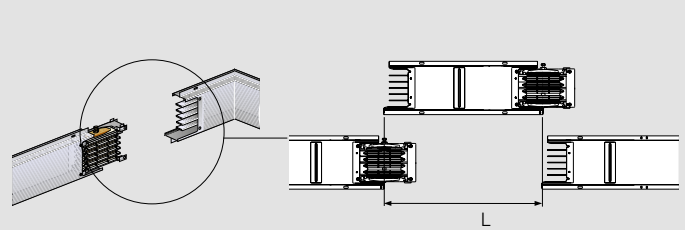

#### ■ Elbows

When using elbows, the dimension should be measured from the long casing to the axis of the element

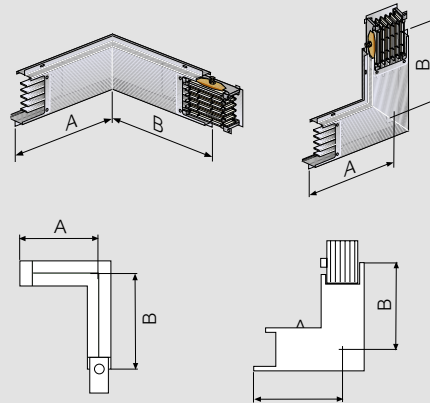

#### ■ Minimum fixing distances

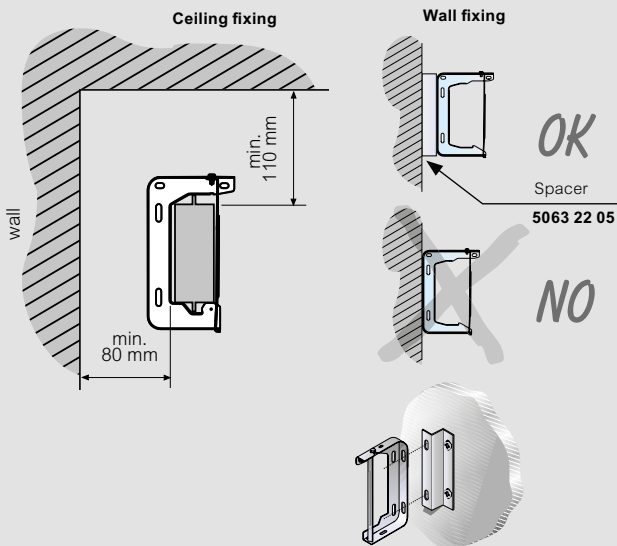

Do not fix the bracket directly on the wall.  
Use the special spacer 5063 22 05



# TROLLEY SYSTEM

Every time when  
the power required  
is on the move

## BUSBAR FROM 63 TO 250 A

**TS/MTS (Trolley System)** is the range of busbars for the power supply to moving users, like: bridge cranes, transfer motors, assembly lines, etc.

### Range

The main features of the **TS/MTS range** are:

- Installation speed, thanks to the electric connection using clamps;
- wide range of bracketing accessories;
- adaptation for the realisation of both straight and curved lines (changes of paths on one plane only);
- compliance with the IEC 61439-6 standard;
- reference room temperature 40 °C.
- availability in the versions (3P+N+PE) (5 Conductors), for loads of 63-70-110-150 A and (3P+PE) (4 Conductors) for 250 A load only, where the connected loads are essentially three-phase motors.

#### QUALITY MATERIAL

All the system components and accessories are designed and made using high quality materials.

#### MAXIMUM VERSATILITY

The TS range can be used in a wide range of solutions, thanks to the availability of curved elements for change of direction, and the many sliding junction elements.

#### MAXIMUM STURDINESS

TS busbars and the many accessories available ensure, once assembled, high electrical and mechanical strength, which means that they can also be used in extremely demanding situations.



AUTOMATED WAREHOUSES

(TS)



CRANES

## Installation accessories



Feed unit



End cover



Electric and mechanic junction



Suspension bracket + junction



Suspension bracket



Trolley 40 A

# TRUNKING COMPONENTS AND ADDITIONAL ELEMENTS

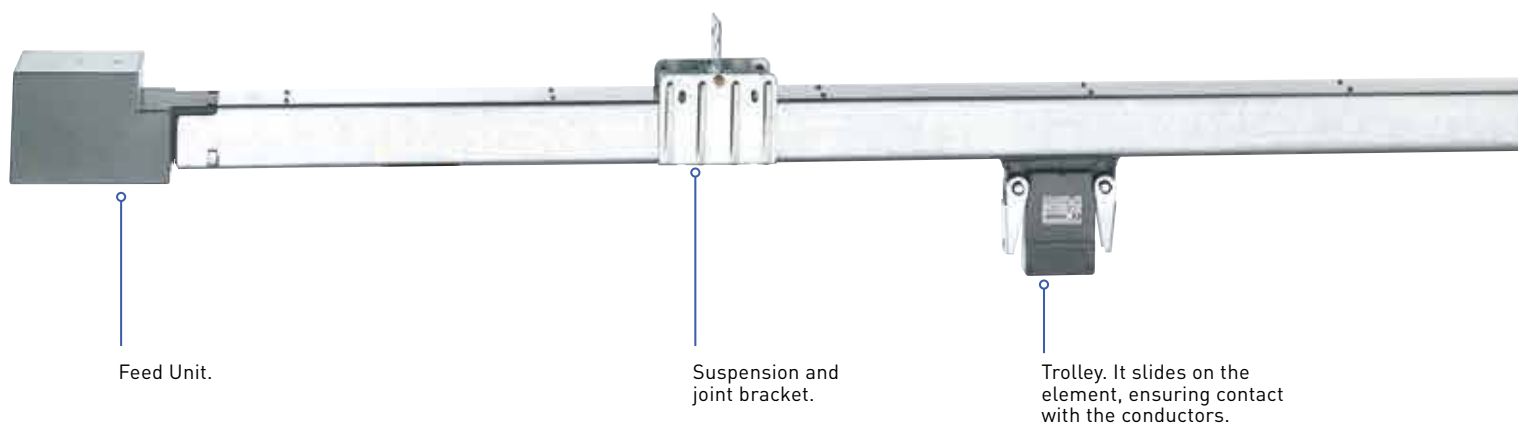

Depending on the different installation requirements Legrand can provide various technical solutions:

- a) curved elements: available for making changes of direction (only horizontally) up to a minimum radius of curvature of 1.5m. There is a quick connection, as with the straight elements. Standard trolleys slide efficiently even within the curved sections of the line. The standard degree of protection is IP20;
- b) straight elements with trolley introduction device: these elements are provided with an access door on the underside. With this door open, it is possible to insert or remove a trolley from the line.

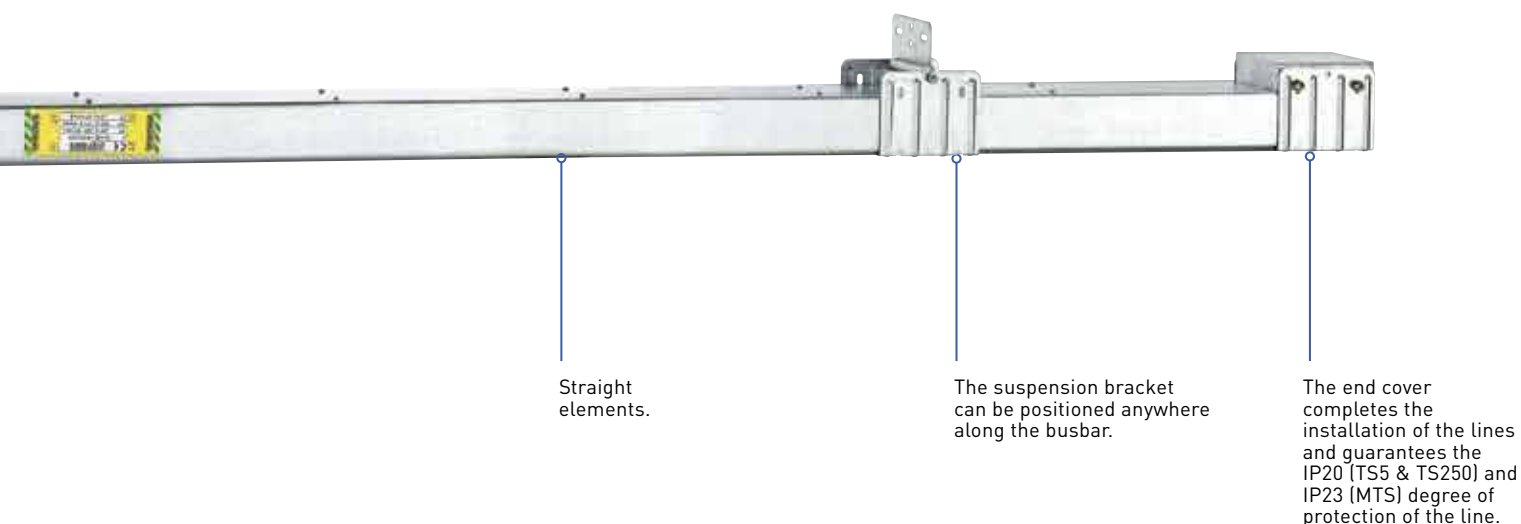

Straight elements.

The suspension bracket can be positioned anywhere along the busbar.

The end cover completes the installation of the lines and guarantees the IP20 (TS5 & TS250) and IP23 (MTS) degree of protection of the line.

Trolleys can generally be put into the line near the end covers. However, when there are lines with several operating trolleys or when using very long lines, it is recommended to use an inserting centre element to make maintenance operations on the trolleys easier. The standard degree of protection is IP20;

c) straight lengths with thermal expansion device. These elements are necessary in lines exceeding 35-40 m in length. Expansion elements absorb and compensate the thermal expansion of the conductors preventing them from losing their linearity, avoiding the reduction of the air insulation distances and obstructing the sliding action of the trolleys.

## Trolley system (TS/MTS) 63 - 250 A

trunking components

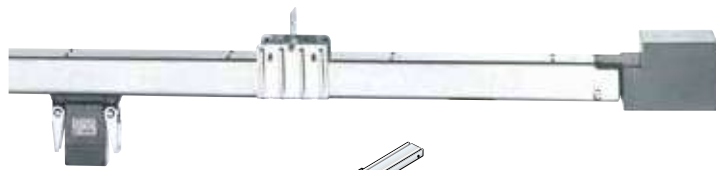

TS

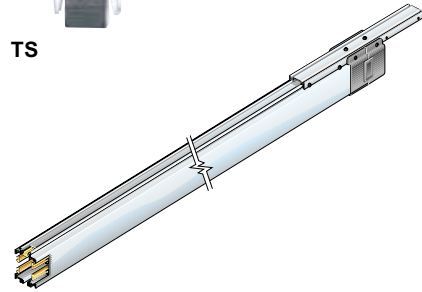

MTS

Reference standard: IEC 61439-6  
 Reference temperature: 40 °C  
 Protection degree: IP20(TS) - IP23(MTS)  
 Thickness: 1.2 mm for TS5 - 1.5 mm for TS250 - 1.4 mm for MTS63;  
 Dimension: TS5 65.5x98 mm; TS250 103x144 mm; 57x44.8 mm;  
 N° of conductors: 5 conductors with same section  
 3P+N+PE (TS5 & MTS63) and 4 for the TS 250 A.  
 The conductors are made of 99.9% pure electrolytic copper

Pack	Cat.Nos		Straight elements	
	L = 3 m	L = 1.5 m	In (A)	Type
1	84500101	84500111	63	MTS63
1	80520101	80530102	70	
1	80530101	80530102	110	TS5
1	80540101	80540102	150	
1	82200101	82200102	250	TS250

Pack	Cat.Nos	Straight elements with trolley introduction device	
		In (A)	Type
1	80530201	70	TS5
1	80530201	110	
1	80540201	150	TS250
5	82200201	250	

## Trolley system (TS/MTS) 63 - 250 A

trunking components

### Dimensions

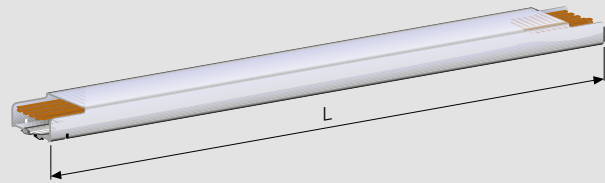

### TS5 - 3P+N+PE - 70-110-150A (IP20)

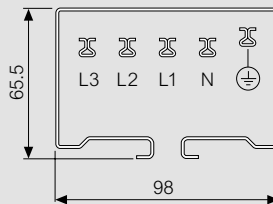

In (A)	Item code	L (mm)	Weight (kg)
70	80520101	3000	12
110	80530101	3000	12.5
150	80540101	3000	13
70	80530102	1500	6
110	80530102	1500	6
150	80540102	1500	6.5

### TS250 - 3P+PE - 250A (IP20)

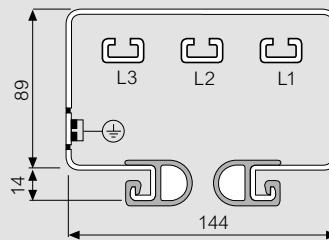

In (A)	Item code	L (mm)	Weight (kg)
250	82200101	3000	29.2
	82200102	1500	15

### MTS63 - 3P+N+PE - 63A (IP23)

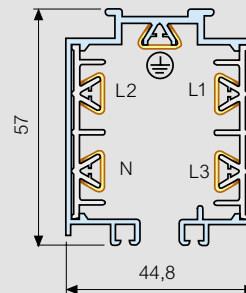

In (A)	Item code	L (mm)	Weight (kg)
63	84500101	3000	5
	84500111	1500	2.5

### Straight elements with trolley introduction device

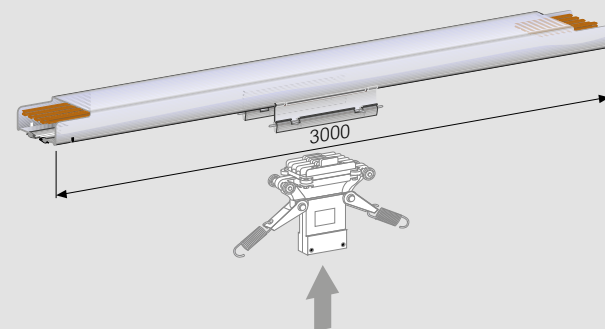

In (A)	Item code	Weight (kg)
70/110	80530201	13
150	80540201	13.5
250	82200201	29.2

## Trolley system (TS/MTS) 63 - 250 A

### trunking components

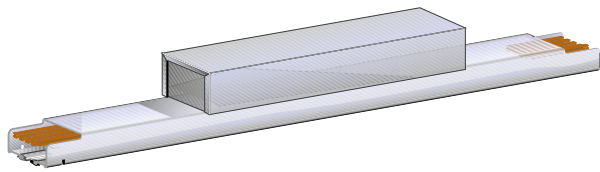

80530301



80530401

Pack	Cat.Nos	Straight element with expansion joint		
	<b>L = 3 m</b>	In (A)	Type	
1	80530301	70	TS5	It compensates the expansion effects of the busbar conductors resulting from the temperature variations of the conductors. It is recommended to use it every 35-40m of line
1	80530301	110		
1	80540301	150		
1	82200301	250	TS250	

Pack	Cat.Nos	Curved elements		
	<b>max L = 2.5 m</b>	In (A)	Type	
1	80530401	70	TS5	
1	80530401	110		
1	80540401	150		

Pack	Cat.Nos	In (A)	Type
1	80045504	max 160	TS5 (Set of three NH 00 fuse carriers)
1	84505004	max 25	MTS63 (Used for local protection) fuses (10.3 x 38)

Fuses not included

## Trolley system (TS/MTS) 63 - 250 A

### trunking components

#### Dimensions

##### Straight element with expansion joint

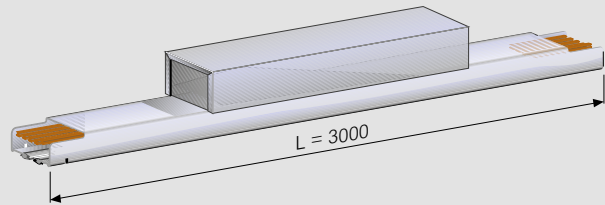

In (A)	Item code	Weight (kg)
70	80530301	14
110	80530301	14
150	80540301	14.5
250	82200301	32

##### Curved element

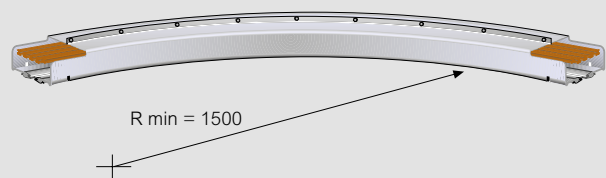

In (A)	max L = 2.5 m
70	80530401
110	80530401
150	80540401

##### Fuse carrier box for lines ranging (from 70 A to 250 A)

Cat.No 80045504

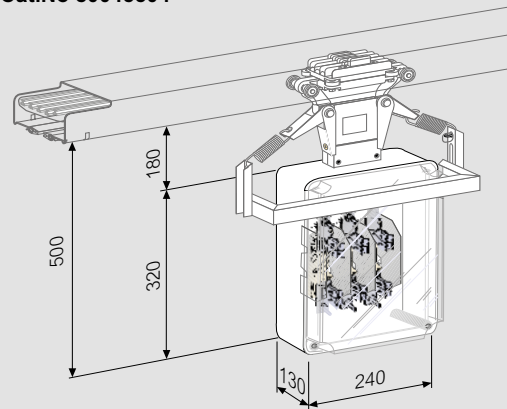

In max 160 A  
Set of three NH 00 fuse carriers  
Fuses not included

##### Fuse carrier box (MTS) - Cat.No 84505004

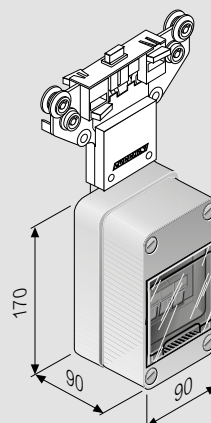

Weight = 0.71 kg

## Trolley system (TS) 70 - 250 A

feed unit and fixing accessories



80541001



80531301



80042101

Pack	Cat.Nos			Feed unit
	TS5 (70-110 A)	TS5 (150 A)	T250 (250 A)	
1	80541001	80541001	82001001	Head
1	80541101	80541101	82001101	Intermediate
1	80531301	80541301	82001301	End cover

Pack	Cat.Nos			Installation accessories
	TS5 (70-110-150 A)	TS5 (150 A)	T250 (250 A)	
5	80542001			Coupling clamp
5	80542002			Suspension coupling clamp
5	80042101			Intermediate suspension bracket
1	82002001			Coupling clamp
1	82002002			Suspension coupling clamp
5	82002101			Intermediate suspension bracket

## Trolley system (TS) 70 - 250 A

feed unit and fixing accessories

### ■ Dimensions

#### Feed unit

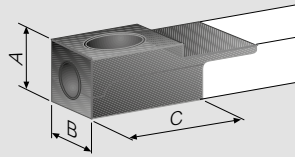

Type	Item code	A (mm)	B (mm)	C (mm)
TS5	80541001	115	150	115
TS250	82001001	125	140	330

#### Intermediate feed unit

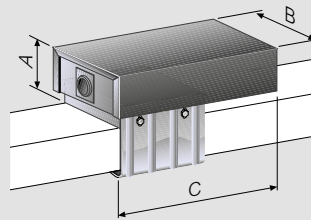

Type	Item code	A (mm)	B (mm)	C (mm)
TS5	80541101	110	130	240
TS250	82001101	140	225	350

Used to power a busbar from any intermediate point. The intermediate feed unit is also used for reducing the voltage drop of the line.

#### End cover

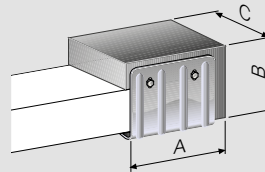

Type	Item code	A (mm)	B (mm)	C (mm)
TS5	80531301	120	92	98
	80541301	120	92	98
TS250	82001301	200	137	143

The end cover can be installed at either end of the busbar.

#### Coupling clamp

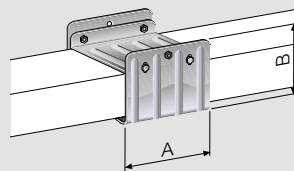

Type	Item code	A (mm)	B (mm)
TS5	80542001	120	95
TS250	82002001	200	137

Use one piece for each element. Provides the mechanical and electrical connection between two elements.

#### Suspension coupling clamp

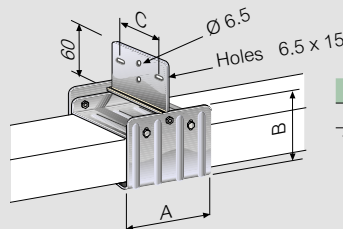

Type	Item code	A (mm)	B (mm)	C (mm)
TS5	80542002	120	95	62
TS250	82002002	200	137	108

Provides the mechanical and electrical connection between two elements as well as a suspension point.

#### Intermediate suspension bracket

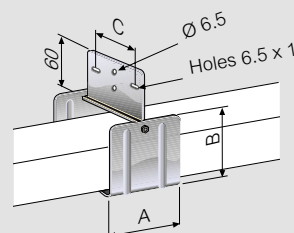

Type	Item code	A (mm)	B (mm)	C (mm)
TS5	80042101	50	95	62
TS250	82002101	70	120	108

It allows the possibility to hang the busbar anywhere along the line. Use one every 2 metres

Note: All drawings are refer at TS5

# Trolley system (MTS) 63 A

## feed unit and fixing accessories

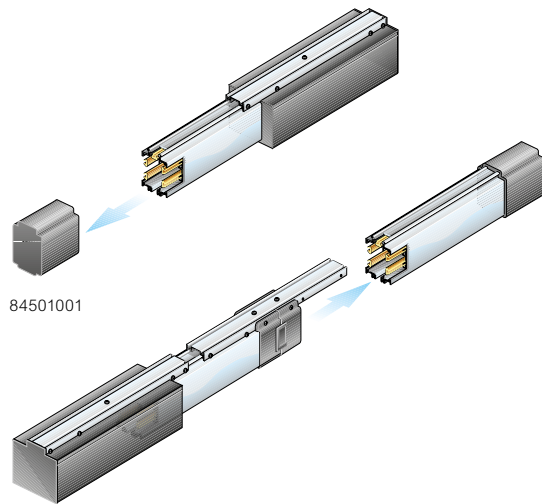

84501001

84501002

Pack	Cat.Nos	Feed unit
	<b>MTS63 (63 A)</b>	
1	84501001	Feed Unit RH + end cover RH
1	84501002	Feed Unit LH + end cover LH
	<b>MTS63 (63 A)</b>	<b>Installation accessories</b>
1	71003001	Standard suspension bracket (Type A)
5	84502101	Ceiling suspension bracket (Type B)

**Note:** RH= right LH= left

# Trolley system (MTS) 63 A

## feed unit and fixing accessories

### ■ Dimensions

#### Feed Unit RH

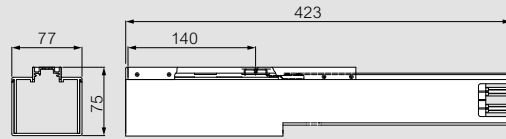

#### End cover RH

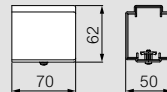

Feed Unit RH + end cover RH	
Item code	Weight (kg)
84501001	1

#### Feed Unit LH

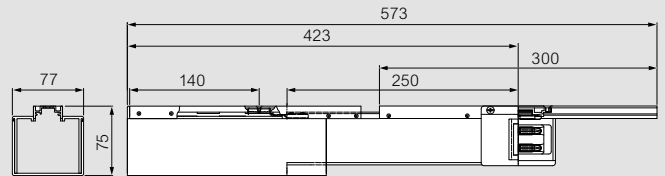

#### End cover LH

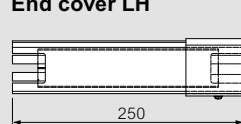

Feed Unit LH + end cover LH	
Item code	Weight (kg)
84501002	1.5

#### Suspension bracket

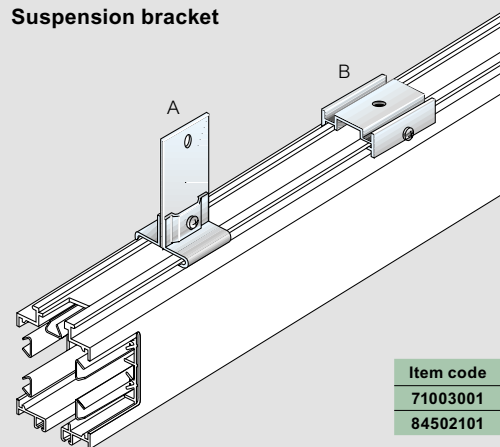

Item code	Type	
71003001	A	Standard
84502101	B	Ceiling

## Trolley system (TS/MTS) 63 - 250 A

fixing accessories

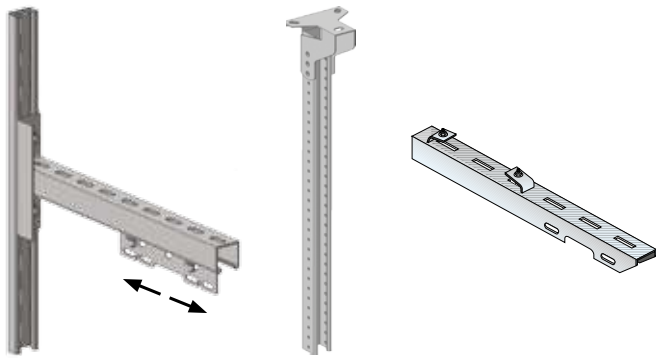

Pack	Cat.Nos	Brackets holders
4	50632212	Wall fixing brackets L= 0.45 m - load max = 80 kg
4	50632213	Wall fixing brackets L= 0.55 m - load max = 68 kg
2	50632214	Wall fixing brackets L= 0.75 m - load max = 50 kg
10	50632201	Ceiling flange
10	50632202	U-shaped bar L = 500 mm
5	50632203	U-shaped bar L = 1 m
1	50632204	U-shaped bar L = 2 m
10	50632210	Bracket holder for beam fixing. This bracket holder has a bracket and two clamps that are hooked to the wings of the beam.

## Trolley system (TS/MTS) 63 - 250 A

fixing accessories

### Dimensions

#### Brackets holders

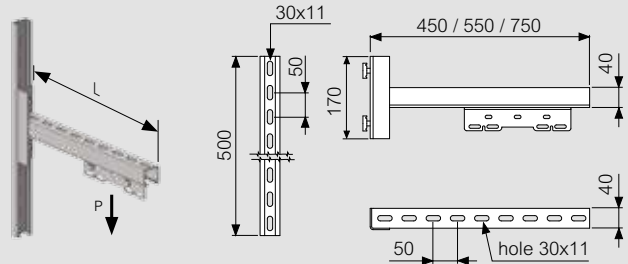

Item code	Lenght	Point of load	Weight (kg)
5063 22 12	L= 0.45 m	p max = 80 kg	2.80
5063 22 13	L= 0.55 m	p max = 68 kg	3.00
5063 22 14	L= 0.75 m	p max = 50 kg	3.50

Shelf continuously adjustable in both height and depth.  
The bracket holder is usable with the busbars MR - MS - TS.

#### Ceiling brackets

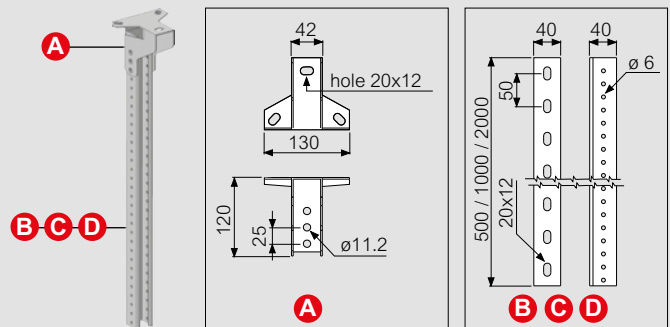

Item code	Description	Fig.	Weight (kg)
50632201	Ceiling flange	A	0.66
50632202	U-shaped bar L = 500 mm	B	1.0
50632203	U-shaped bar L = 1000 mm	C	1.5
50632204	U-shaped bar L = 2000 mm	D	2.0

#### Beam bracket

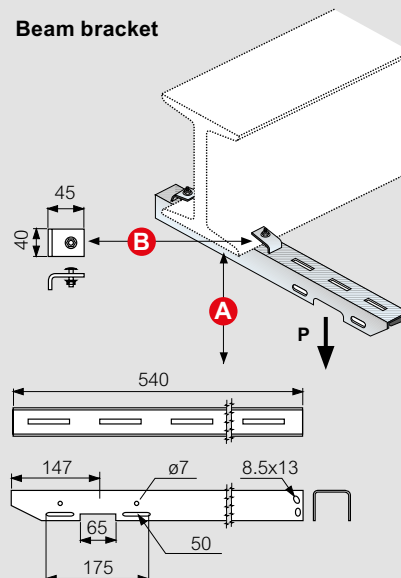

Item code	Fig.	Weight (kg)
50632210	A	0.90
	B	0.90

A - max weight = 65 kg

# Trolley system (TS/MTS) 63 - 250 A

## installation accessories



80545002

Pack	Cat.Nos			Installation accessories
	TS5 (70-110-150 A)	TS250 (250 A)	MTS63 (63 A)	
1	80545002	82205001	84505001	Trolley
1	80045201	80045201	-	Drive arms (standard)
1	80045202	80045202	-	Drive arms (double)
1	80045203	80045203	-	Bracket for coupling trolley

# Trolley system (TS/MTS) 63 - 250 A

## installation accessories

### ■ Dimensions

#### Power socket carrier

**TS5 - 80545002**  
40 A (3P + N + T)

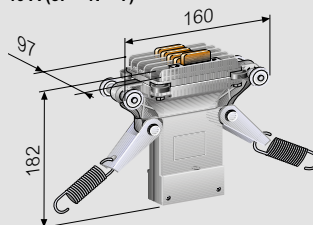

The 40A trolley has graphite contacts which ensure electrical continuity. An 80A rating can be achieved by connecting two trolleys in parallel using the coupling bracket (code 80045203). It works properly up to a sliding speed of 90m/min and withstands weights up to 30 kg

Always pull the trolley by means of its springs

**TS250 - 82205001**  
80 A (3P + T)

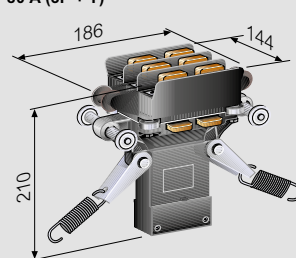

The driving action of the trolleys shall always be carried out with its springs. The trolley used for the 250A (3P+T) Trolley line is available for an 80A rating. The contacts are of the sliding type, two for each phase. The earth contacts are located beside the trolley and ensure a constant and efficient contact. It works properly up to a sliding speed of 90 m/min and withstands weights up to 30 kg

**MTS63 - 84505001**  
25 A (3P+N+T)

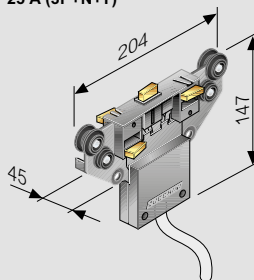

The 25A trolley has graphite contacts which ensure electrical continuity. It works properly up to a sliding speed of 150 m/min and withstands weights up to 30 kg

Type	Item code	Weight (kg)
MTS 63	<b>84505001</b>	0.32
TS5	<b>80545002</b>	1.1
TS250	<b>82205001</b>	1.97

#### Drive arms TS5 - TS250 (art.80045201 and 80045202)

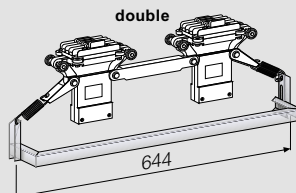
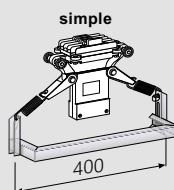

In order to have a perfect alignment and an excellent sliding action, a driving arm is essential. It adjusts the trolley both horizontally and vertically

#### Bracket for coupling trolleys TS5 - TS250 (art.80045203)

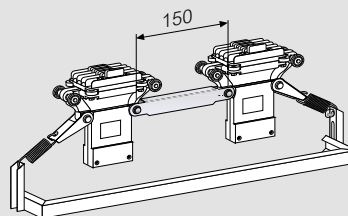

The coupling bracket can connect two trolleys together, thus allowing you to obtain for:

- TS5 = 80A
- TS250 = 160A

# Trolley system (TS/MTS)

## technical data

TROLLEY SYSTEM (TS)						
		MTS63	TS5			TS250
		3P+N+T	3P+N+T			3P+T
Number of live conductors						
Casing overall dimensions	[mm]	44.8x57	98x65.5			144x89
Rated current	$I_n$ [A]	63	70	110	150	250
Operating voltage	$U_e$ [V]	400	600			600
Insulation voltage	$U_i$ [V]	750				
Rated frequency	$f$ [Hz]	50/60				
Rated short-time current (0.1 s)	$I_{cw}$ [kA] <sub>rms</sub>	5	9			11
Allowable peak current	$I_{pk}$ [kA]	7.5	15.3			18.7
Thermal limit	$I^2t$ [M A <sup>2</sup> s]	25	81			121
Phase resistance	[mΩ/m]	1.500	0.947	0.785	0.515	0.255
Phase reactance at 50Hz	$X$ [mΩ/m]	1.400	0.059	0.063	0.092	0.161
Phase impedance	$Z$ [mΩ/m]	2.052	0.949	0.788	0.523	0.302
Resistance of the protective conductor	[mΩ/m]	1.500	0.947	0.785	0.515	0.150
Reactance of the protective conductor at 50Hz	[mΩ/m]	0.080	0.100	0.100	0.100	0.120
Resistance of the fault loop	[mΩ/m]	3.000	1.895	1.570	1.030	0.405
Reactance of the fault loop at 50Hz	[mΩ/m]	1.480	0.159	0.163	0.192	0.281
Impedance of the fault loop	[mΩ/m]	3.345	1.901	1.578	1.048	0.493
Voltage drop with distributed load referred to $\Delta V_{3f}$ (*)	$\Delta V$ [V/m/A] $10^{-3} \cos\varphi = 0.7$	1.775	0.611	0.515	0.369	0.254
	$\Delta V$ [V/m/A] $10^{-3} \cos\varphi = 0.75$	1.776	0.649	0.546	0.387	0.258
	$\Delta V$ [V/m/A] $10^{-3} \cos\varphi = 0.80$	1.767	0.687	0.577	0.405	0.260
	$\Delta V$ [V/m/A] $10^{-3} \cos\varphi = 0.85$	1.743	0.724	0.607	0.421	0.261
	$\Delta V$ [V/m/A] $10^{-3} \cos\varphi = 0.90$	1.698	0.761	0.636	0.436	0.260
	$\Delta V$ [V/m/A] $10^{-3} \cos\varphi = 0.95$	1.613	0.795	0.663	0.449	0.253
	$\Delta V$ [V/m/A] $10^{-3} \cos\varphi = 1$	1.299	0.820	0.680	0.446	0.221
Straight element weight	$P$ [kg/m]	1.0	4.0	4.1	4.2	9.8
Maximum Speed of Trolley	[m/min]	150	90			90
Protection degree	IP	23	20			20
Joule effect losses at $I_n$	$P$ [W/m]	17.9	13.9	28.5	34.8	47.8
Ambient temperature	$t$ [°C]	-5/+50				

(\*) **THREE-PHASE:**  $\Delta V_{3f} = \sqrt{3}/2 \times (R_t \cos\varphi + X \sin\varphi)$   
 $\Delta V_{3f}(I_n) = I \times L \times \Delta V_{3f}$ : (knowing the current and length of the line)  
 $\Delta V_{3f}(I_n)\% = (\Delta V_{3f}(I_n) / U_e) \times 100$  (%)

To calculate the  **$\Delta V_{1f}$  (SINGLE-PHASE) on distributed load:**

$\Delta V_{1f} = 1/2 \times (2R_t \cos\varphi + 2X \sin\varphi)$   
 $\Delta V_{1f}(I_n) = I \times L \times \Delta V_{1f}$ : (knowing the current and length of the line)  
 $\Delta V_{1f}(I_n)\% = (\Delta V_{1f}(I_n) / U_e) \times 100$  (%)

$I$  = operating current (A)

$L$  = length (m)

# Trolley system (TS/MTS)

## technical informations

### ■ Straight elements

The components and the features of the TS straight elements are:

- casing made with a hot galvanized steel for TS5 and TS250;
- sheet metal thickness: 1.2 mm for TS5 and 1.5 mm for TS250;
- As for the 63A (MTS63) rating, the casing is made of extruded aluminium with a minimum thickness of 1.4 mm; it has good mechanical rigidity and preserves its linearity over time.
- number of conductors: 5 conductors with same section 3P+N+PE (TS5 and MTS63) and 4 conductors 3P+PE (TS 250A), shaped to guarantee excellent mechanical strength. The conductors are made of 99.9% pure electrolytic copper;
- separation between the conductors using fibreglass reinforced plastic material ensuring a V1 selfextinguishing degree (according to UL94) and in compliance with the glow-wire test according to IEC 60695-2-10;
- the slot along the underside of the busbar allows a current trolley to slide in it. The size of the slot ensures an IP20 degree of protection for TS5 and TS250. and IP23 degree protection for MTS63;
- an independent electrical junction terminal system (made of bronze plates) for fast and reliable connection of the live conductors and the PE. The terminals make an electric connection between the conductors, with a smooth flat lower part in order to make the trolleys slide more easily. The whole busbar is "fire retardant" in compliance with the standard IEC 60332-3

### ■ Feed units

Allows you to electrically power the TS busbar through a cable line; the installation is carried out with a quick terminal connection as with the straight elements. The entrance point of the cables is generally positioned on the back side of the feed unit. The TS range has centre feed units which can be installed wherever there is a junction between the straight elements

### ■ End cover

The end cover ensures the IP20 (TS5 and TS250) and IP23 (MTS63) protection degree at the end of the line

### ■ Fixing supports

In order to fix the line to the structure of the building, directly or with wall / ceiling / beam supports, it is necessary to use a bracket which serves as a collar around the busbar. An electrical junction, which can also serve for suspending the busbar, is available on the TS line. The bracket has holes so it can be easily paired with the supports available in the catalogue

### ■ Trolleys

These are used for connecting and supplying power for 25A – 40 A – 80 A or 160 A three-phase loads (in the coupled version); their features include:

- The trolleys are equipped with 5 graphite brushes (3P+N+PE) which, due to the spring action, keep the correct pressure on the conductors enabling them to pick up current from the line while the trolley is moving (travelling) inside the TS busbar
- The trolleys can be coupled with a mechanical joint so as to pickup twice the rated current of a single trolley
- The trolley is coupled to the motor with a "drive arm" which receives the movement from the same electric motor supplying power to it
- The drive arms are connected to the trolleys with special springs which reduce the acceleration (so-called "sudden pulls") when starting up and when braking;
- Maximum travelling speed of the trolleys is 90 m/min (150 m/min for the MTS 63A)
- Availability, on request, of a box with a set of three fuse carriers, used as an accessory, to protect the cable from overcurrents
- compliance with all insulating plastic components according to the glow-wire test (IEC 60695-2-10) with V1 self-extinguishing degree (UL94)
- Standard IP20 degree of protection without using additional accessories



# SUPER COMPACT

The power solutions for industrial and service sector applications

## BUSBAR FROM 630 TO 6300 A

SCP (**SuperCompact Painted**) is the range used for transport and distribution of High Power, and is also highly valued in rising mains. The applications include all industrial, commercial and service sector buildings (factories, banks, trade and business centres, hospitals, data center, etc.)

## Range

The main features of the **SCP range** are:

- availability in the standard range: **from 630 A to 5000 A\*** with **aluminum alloy conductors** and **from 800 A to 6300 A\*** with **copper** conductors.
- low impedance of the circuit;
- availability with **a wide selection of tap-off boxes that range from 63 A up to 1250 A**, thus allowing you to locally protect and feed different types of loads by housing protective devices such as fuses, MCCBs and motorised switches.

- compliance with the IEC 61439-6 standard;

- **referred to the average ambient temperature of 40 °C** against the 35 °C required by the Standard.

### ULTRA-COMPACT SIZES

The super-compact dimensions enhance **its resistance to short circuit stresses**; in addition, they can reduce the impedance of the circuit by controlling the voltage drops and allow for the installation of high power electrical systems, even in extremely confined spaces.

### EXCELLENT PERFORMANCES

The installation and design of the paths is quick, easy, and flexible, and the sizes are ultra-compact.

\*5000A(Al) and 6300A(Cu) only for transport of energy

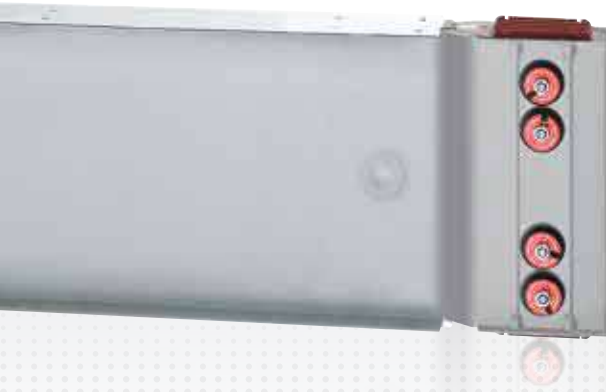

(SCP)



AIRPORT



BIG INDUSTRY

## Installation accessories



Horizontal elbow



Vertical elbow



Connection interface



Junction

# MAIN FEATURES OF THE SCP LINE

## Straight elements:

Supplied with its pre-installed monobloc.

## Feeder elements:

- standard length: 3 m
- special length: from 0.7 m to 3 m

## Distribution elements with tap-off outlets:

- standard length: 3 m
- standard tap-off sockets:  
spaced at 850 mm intervals on both sides

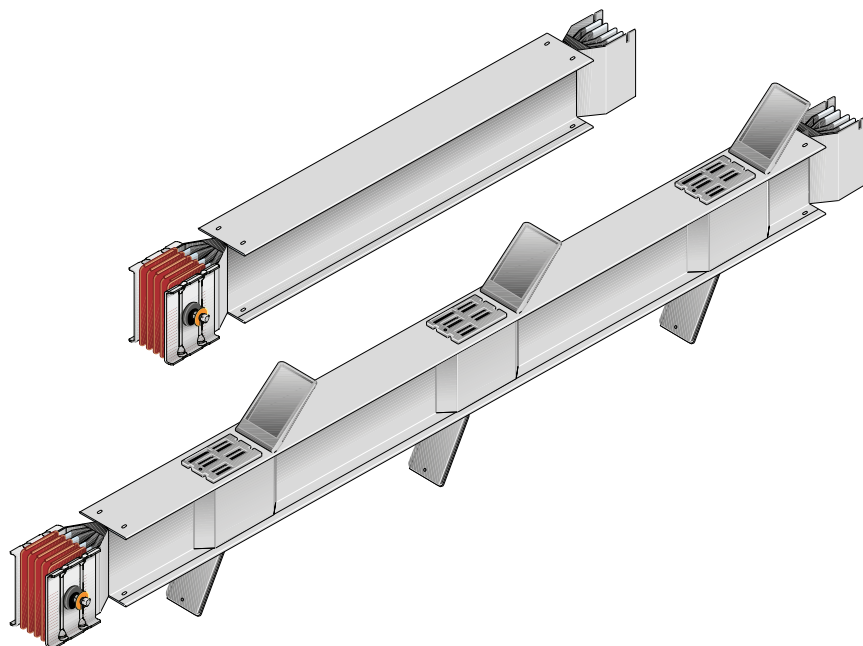

## Additional elements:

Supplied with its pre-installed monobloc.  
Elements able to meet any installation requirement.

**Elements with S120 fire barrier**

**Elements with phase balancing**

**Elements with thermal expansion device**

**Elements with phase inversion**

**Elements with neutral rotation**

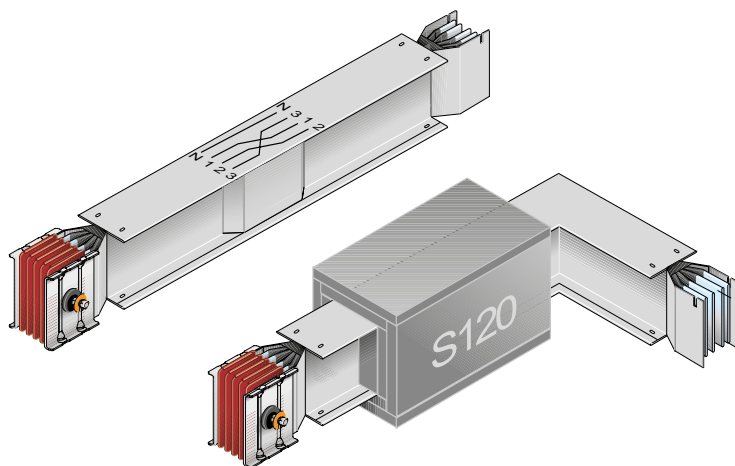

## Angle components:

Supplied with its pre-installed monobloc.  
Elements able to meet any change of direction  
with standard or special solutions.

**Elbows**

**Double elbows**

**Special T, X elements**

**Elbows with special degree (not 90°)  
please contact directly Legrand**

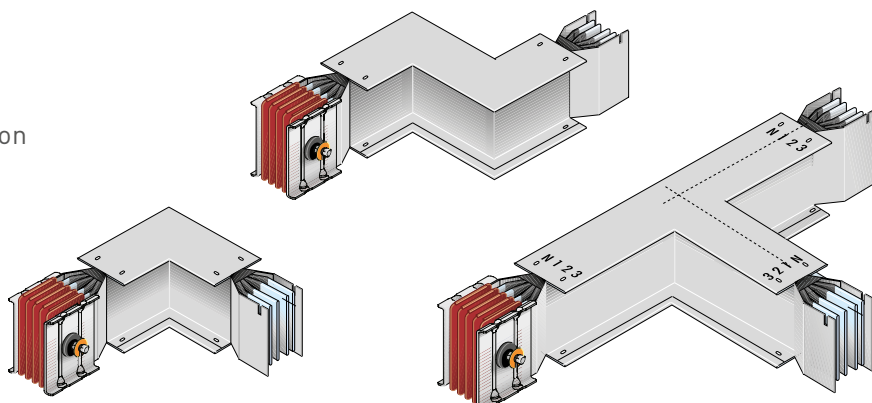

## Tap-off boxes:

Elements used for connecting and energizing electric loads.

### Plug-in tap-off boxes from 63 A up to 630 A: (can be installed with busbar energized)

- with 3P fuse holders
- with switch disconnecter and fuse holder
- for DPX circuit breakers

### Bolted tap-off boxes from 125 A to 1250 A:

- with switch disconnecter and fuse holder
- for DPX circuit breakers

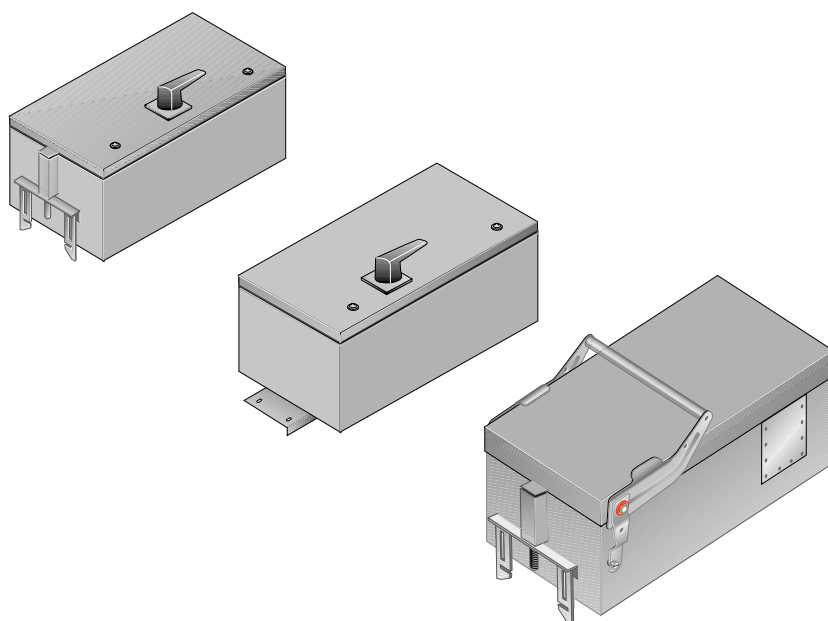

## Connection interfaces:

Elements used for connecting the busbar to the electric board or transformer.

### Solutions for Legrand XL<sup>3</sup> cabinets and Legrand cast resin transformers

#### Universal solutions

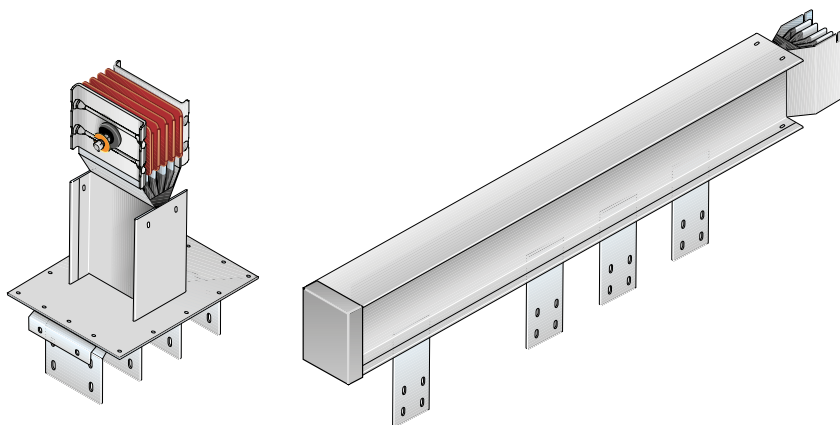

## Fixing supports:

Elements used for fixing the busbar to the structure of the building.

### Options for horizontal installations

### Options for vertical installations

### Options for special applications

(seismic areas, naval environment)

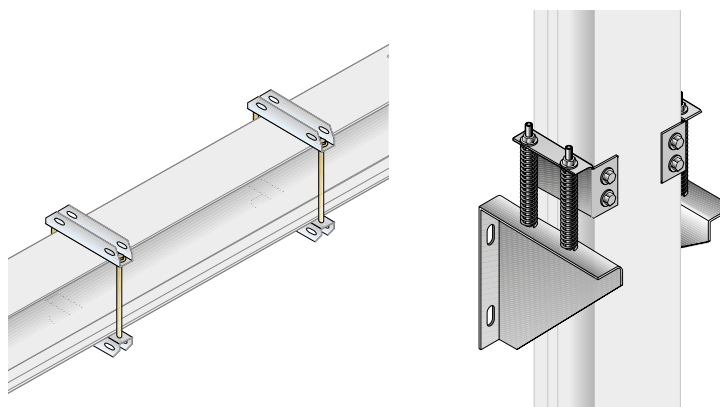

## Super compact (SCP)

### straight elements

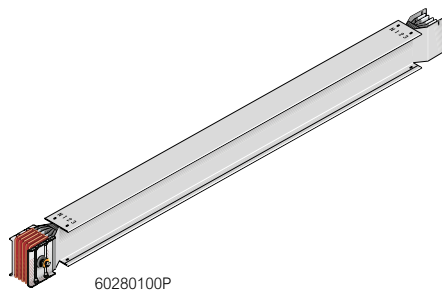

60280100P

#### SCP Line:

Reference standard: IEC 61439-6. Reference temperature: 40 °C  
 Protection degree: IP55. Thickness: 1.5 mm  
 N° of conductors: 3, 4 or 5. Painted: RAL 7035 . Halogen Free  
 The insulation between bars is ensured by a double sheath made with polyester film class B(130°C), class F (155°C) thermal resistance available on request  
 All plastic components have a V1 self-extinguishing degree (as per UL94); they are fire retardant and comply with the glow-wire test according to standards

Pack	Cat.Nos		ln (A)	L (mm)
	Al	Cu		
1	60280100P	-	630	3000
1	60280101P	65280100P	800	
1	60280102P	65280101P	1000	
1	60280104P	65280103P	1250	
1	60280106P	65280105P	1600	
1	60280107P	65280106P	2000	
1	60390104P	65280108P	2500	
1	60390106P	65390105P	3200	
1	60390107P	65390106P	4000	
1	-	65390108P	5000	
1	60280170P	-	630	1000-1500
1	60280171P	65280170P	800	
1	60280172P	65280171P	1000	
1	60280174P	65280173P	1250	
1	60280176P	65280175P	1600	
1	60280177P	65280176P	2000	
1	60390174P	65280178P	2500	
1	60390176P	65390175P	3200	
1	60390177P	65390176P	4000	
1	-	65390178P	5000	
1	60280120P	-	630	1501-2000
1	60280121P	65280120P	800	
1	60280122P	65280121P	1000	
1	60280124P	65280123P	1250	
1	60280126P	65280125P	1600	
1	60280127P	65280126P	2000	
1	60390124P	65280128P	2500	
1	60390126P	65390125P	3200	
1	60390127P	65390126P	4000	
1	-	65390128P	5000	
1	60280180P	-	630	2001-2500
1	60280181P	65280180P	800	
1	60280182P	65280181P	1000	
1	60280184P	65280183P	1250	
1	60280186P	65280185P	1600	
1	60280187P	65280186P	2000	
1	60390184P	65280188P	2500	
1	60390186P	65390185P	3200	
1	60390187P	65390186P	4000	
1	-	65390188P	5000	
1	60280150P	-	630	2501-2999
1	60280151P	65280150P	800	
1	60280152P	65280151P	1000	
1	60280154P	65280153P	1250	
1	60280156P	65280155P	1600	
1	60280157P	65280156P	2000	
1	60390154P	65280158P	2500	
1	60390156P	65390155P	3200	
1	60390157P	65390156P	4000	
1	-	65390158P	5000	

## Super compact (SCP)

### straight elements

#### Dimensions

#### Straight elements

Standard 3000 mm

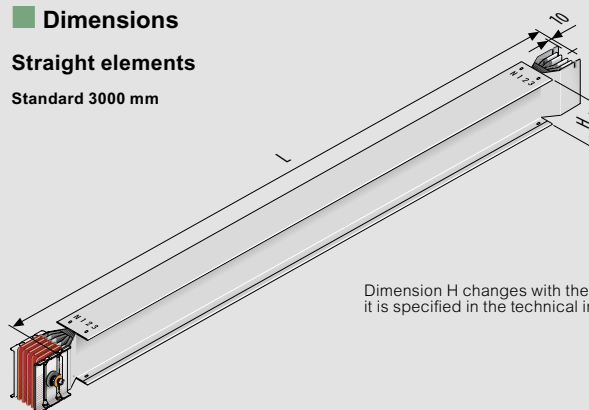

Dimension H changes with the rating; it is specified in the technical informations

#### MIN AND MAX DIMENSIONS OF SINGLE AND DOUBLE BAR

Aluminium (Al)	630A – 5000A
Copper (Cu)	800A – 6300A
(L) min/MAX [mm]	700/3000

Straight elements are available on request only for transport of energy:  
 Al : 5000A  
 Cu : 6300A

#### NOTES

The product versions in the whole catalogue will be simplified as shown opposite, highlighting the part with the monobloc installed in red and the neutral side in blue. In the whole catalogue, the measurements shown refer to the element centre distance

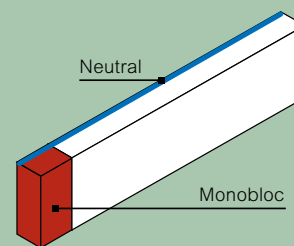

The range is also available on request in different versions: (5 Conductors with dedicated PE conductor, double neutral and more others...)



**Single bar:**  
 630A-2000A (Al)  
 800A-2500A (Cu)

**Double bar:**  
 2500A-4000A (Al)  
 3200A-5000A (Cu)

## Super compact (SCP)

### straight elements (continued)

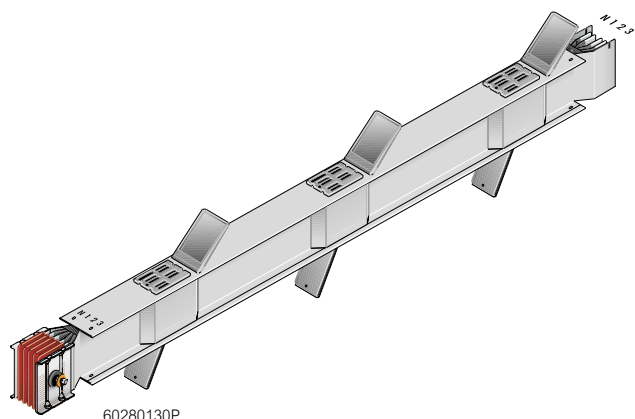

Pack	Cat.Nos		Straight elements for distribution		
	Al	Cu	In (A)	N° outlets	L (mm)
1	*60280130P	-	630	3+3 **	3000
1	60280131P	*65280130P	800		
1	60280132P	65280131P	1000		
1	60280134P	65280133P	1250		
1	60280136P	65280135P	1600		
1	60280137P	65280136P	2000		
1	60390134P	65280138P	2500		
1	60390136P	65390135P	3200		
1	60390137P	65390136P	4000		
1	-	65390138P	5000		
1	*60280970P	-	630	1+1	1000-1500
1	60280971P	*65280970P	800		
1	60280972P	65280971P	1000		
1	60280974P	65280973P	1250		
1	60280976P	65280975P	1600		
1	60280977P	65280976P	2000		
1	60390974P	65280978P	2500		
1	60390976P	65390975P	3200		
1	60390977P	65390976P	4000		
1	-	65390978P	5000		
1	*60280920P	-	630	2+2 **	1501-2000
1	60280921P	*65280920P	800		
1	60280922P	65280921P	1000		
1	60280924P	65280923P	1250		
1	60280926P	65280925P	1600		
1	60280927P	65280926P	2000		
1	60390924P	65280928P	2500		
1	60390926P	65390925P	3200		
1	60390927P	65390926P	4000		
1	-	65390928P	5000		
1	*60280980P	-	630	2+2 **	2001-2500
1	60280981P	*65280980P	800		
1	60280982P	65280981P	1000		
1	60280984P	65280983P	1250		
1	60280986P	65280985P	1600		
1	60280987P	65280986P	2000		
1	60390984P	65280988P	2500		
1	60390986P	65390985P	3200		
1	60390987P	65390986P	4000		
1	-	65390988P	5000		
1	*60280950P	-	630	3+3 **	2501-2999
1	60280951P	*65280950P	800		
1	60280952P	65280951P	1000		
1	60280954P	65280953P	1250		
1	60280956P	65280955P	1600		
1	60280957P	65280956P	2000		
1	60390954P	65280958P	2500		
1	60390956P	65390955P	3200		
1	60390957P	65390956P	4000		
1	-	65390958P	5000		

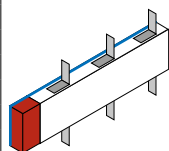

## Super compact (SCP)

### straight elements (continued)

#### Dimensions

##### Straight elements for distribution

- Straight elements for plug-in type tap-off boxes on appropriate outlets
- Standard 3000 mm
- Tap-off outlets on both sides

Straight elements enable the application of plug-in boxes on appropriate outlets

Available in lengths from 1 to 3 meters, these elements have respectively 1, 2 and 3 outlets at preset distances with centre distances of 850 mm on both side

(\*) The exception to these are 630 A elements with Aluminium conductors (Al) and 800 A elements with Copper conductors (Cu), where distributions are only available on the top side (in standard execution) for example "3+0"

On request, the length of the elements and the number and position of distribution outlets may be different from the standards

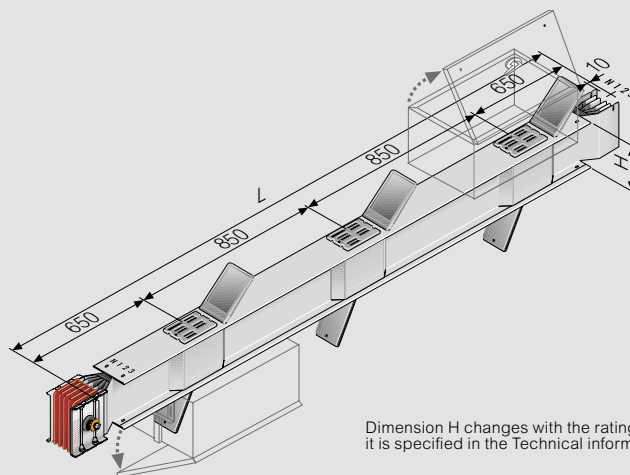

Dimension H changes with the ratings and it is specified in the Technical informations

#### MIN AND MAX DIMENSIONS OF SINGLE AND DOUBLE BAR

<b>Aluminium (Al)</b>	630A – 4000A
<b>Copper (Cu)</b>	800A – 5000A
<b>(L) min/MAX [mm]</b>	1250 ***/3000

(\*\*\*) For the length from 1000 mm to 1250 mm is possible to install only plug-in boxes Type 1 and 3  
From 1250 mm to 3000 mm is possible to install all types of plug-in boxes  
Compatible boxes are listed in dedicated chapter

(\*\*) at request is possible to have others combinations of outlets:  
length: 1501÷2000 - outlets: (1+1)  
length: 2001÷2500 - outlets: (1+1)  
length: 2501÷2999 - outlets: (1+1) and (2+2)  
length: 3000 - outlets: (1+1) and (2+2)  
Possibility to have outlets in special position

# Super compact (SCP)

straight elements

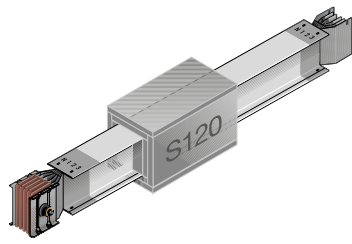

653IFB01

Pack	Cat.Nos		In (A)	Type
	Al	Cu		
	<b>Fire barrier elements S120 (EN 1366-3, DIN 4102-09)</b>			
	When the busbar trunking system crosses fire resistant walls or ceilings, it must be fitted with appropriate fire barriers. The fire barrier is 630 mm (Al) and 1000 mm (Cu) long and must always be positioned in the middle of the fire resistant wall or ceiling crossed by the busbar. After crossing fire resistant walls or ceilings, any cavity must be sealed with material meeting current regulations for the required building fire resistance class.			
1	653IFB01	-	630	internal
1	-	653IFB01	800	
	-	-	1000-2000	
1	653IFB01	-	2500	
1	653IFB01	653IFB01	3200-4000	
1	-	653IFB01	5000	
1	652EFB01	-	630	external
1	652EFB01	652EFB51	800-1250	
1	652EFB02	652EFB52	1600	
1	652EFB04	652EFB52	2000	
1	653EFB02	652EFB54	2500	
1	653EFB03	653EFB52	3200	
1	653EFB04	653EFB53	4000	
1	-	653EFB54	5000	

**Single bar:**  
630A-2000A (Al)  
800A-2500A (Cu)

**Double bar:**  
2500A-4000A (Al)  
3200A-5000A (Cu)

# Super compact (SCP)

straight elements

## Dimensions

### Fire barrier elements S120 (EN 1366-3, DIN 4102-09)

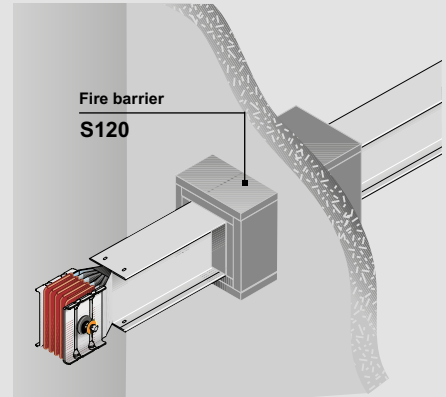
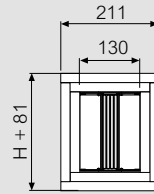

**Fire barrier sizes**  
Dimension H changes with the rating; it is specified in the technical informations

In order to ensure the maximum resistance class, for some ratings it is also necessary to fit at the factory an internal fire barrier following the indications on the table. It is therefore necessary to indicate at the order stage what elements will cross fire resistant walls or ceilings.

Figure 1

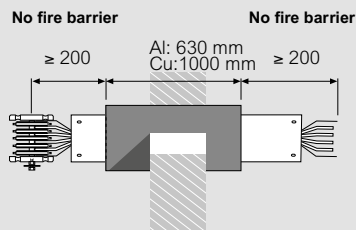
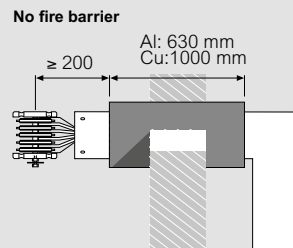

Figure 2



USE OF INTERNAL OR EXTERNAL BARRIER					
In (A)	Al		Cu		
	Internal	External	In (A)	Internal	External
630	✓	✓	800	✓	✓
800-2000	-	✓	1000-2500	-	✓
2500-4000	✓	✓	3200-5000	✓	✓

The external fire barrier can be used on any trunking component in compliance with the operating instructions specified in figures 1 and 2.

# Super compact (SCP)

## straight elements (continued)

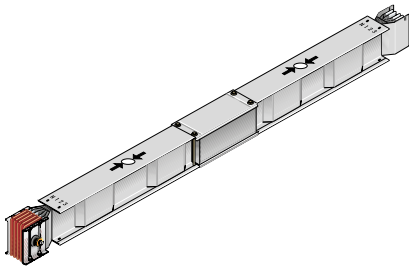

60280290P

Pack	Cat.Nos		Expansion element	
	Al	Cu	In (A)	Type
1	60280290P	-	630	L = 3 m Ideal for horizontal installations
1	60280291P	65280290P	800	
1	60280292P	65280291P	1000	
1	60280294P	65280293P	1250	
1	60280296P	65280295P	1600	
1	60280297P	65280296P	2000	
1	60390294P	65280298P	2500	
1	60390296P	65390295P	3200	
1	60390297P	65390296P	4000	
1	-	65390298P	5000	
1	60280200P	-	630	L = 1.5 m Ideal for rising mains installation
1	60280201P	65280200P	800	
1	60280202P	65280201P	1000	
1	60280204P	65280203P	1250	
1	60280206P	65280205P	1600	
1	60280207P	65280206P	2000	
1	60390204P	65280208P	2500	
1	60390206P	65390205P	3200	
1	60390207P	65390206P	4000	
1	-	65390208P	5000	

**Expansion element**

Due to being subjected to temperature changes, both the busbar and the building suffer thermal expansions. The expansion element can absorb expansion and contraction of both the busbar trunking system section and the building, up to the maximum permitted length (50 mm approx.). The expansion element must be fitted near the expansion joints of the building and in straight sections of the line (horizontal and/or vertical) longer than 40 m. For straight line sections longer than 40 m, expansion elements must be fitted in a way that splits the path into equal sections not longer than 40 m. SCP busbar trunking system elements are designed to compensate for thermal expansion if the straight sections of the installation are less than 40 m; in this case no expansion element is necessary.

# Super compact (SCP)

## straight elements (continued)

### Dimensions

#### Expansion element

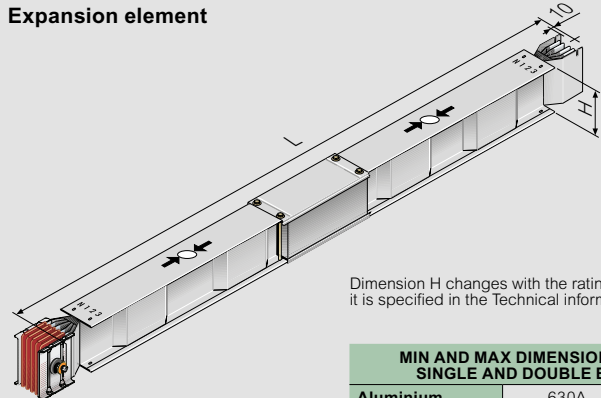

Dimension H changes with the ratings and it is specified in the Technical informations

MIN AND MAX DIMENSIONS OF SINGLE AND DOUBLE BAR	
Aluminium	630A – 4000A
Copper	800A – 5000A
(L) min/MAX [mm]	1500 and 3000

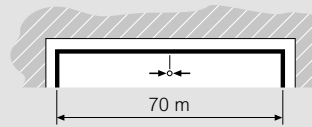

#### Example:

Straight section length 70 m = n°1 expansion element in the center of the line

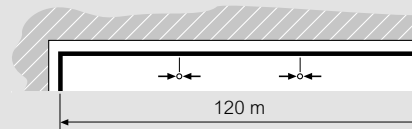

#### Example:

Straight section length 120 m = n°2 expansion elements, one every 40 m

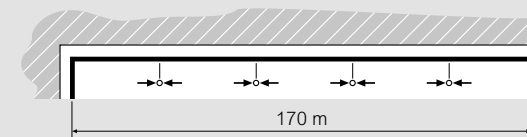

#### Example:

Straight section length 170 m = no. 4 expansion elements, one every 34 m

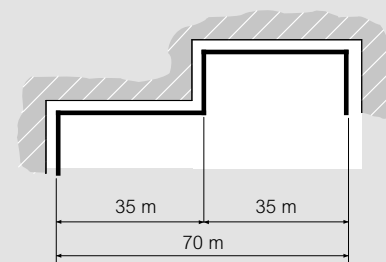

#### Example:

Section length 70 m. When the section is not straight, no expansion element is necessary

## Super compact (SCP)

### straight elements (continued)

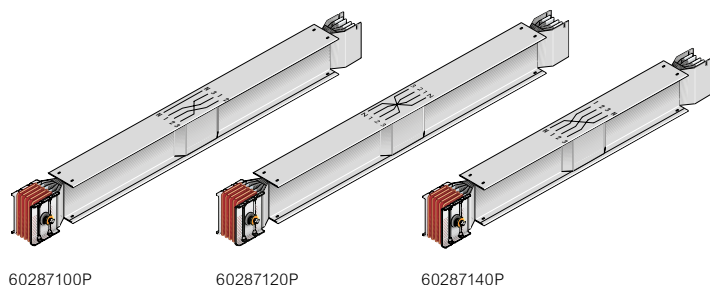

#### Phase balancing

Pack	Cat.Nos		In (A)	Phase balancing
	Al	Cu		
1	60287100P	-	630	Straight elements with phase balancing are used to reduce and balance mutual phase reactance and impedance in case of long lines. In particularly long sections (> 100 metres) it is recommended that two transposition elements are fitted (one at one third and one at two thirds of the path), to balance the system electric impedance: In this way, it will be possible to have along the installation path all the possible combination, of reciprocal positions among phases, minimising load losses
1	60287101P	65287100P	800	
1	60287102P	65287101P	1000	
1	60287104P	65287103P	1250	
1	60287106P	65287105P	1600	
1	60287107P	65287106P	2000	
1	60397104P	65287108P	2500	
1	60397106P	65397105P	3200	
1	60397107P	65397106P	4000	
1	-	65397108P	5000	

#### Phase inversion

Pack	Al	Cu	In (A)	Phase inversion
1	60287120P	-	630	The function of this element is to completely reversed the positions of the phases and the neutral. It is normally used in connections between transformer and electric board, or in the connections between electric boards, when the starting sequence is different from the arrival sequence
1	60287121P	65287120P	800	
1	60287122P	65287121P	1000	
1	60287124P	65287123P	1250	
1	60287126P	65287125P	1600	
1	60287127P	65287126P	2000	
1	60397124P	65287128P	2500	
1	60397126P	65397125P	3200	
1	60397127P	65397126P	4000	
1	-	65397128P	5000	

#### Element with Neutral rotation

Pack	Al	Cu	In (A)	Element with Neutral rotation
1	60287140P	-	630	The straight element with Neutral rotation is used to adapt the sequence of the busbar phases to the sequence of the connections required at the ends of the connections, should these be different. In the connection between electric boards, the neutral jump is normally used, as only the neutral position is normally identified
1	60287141P	65287140P	800	
1	60287142P	65287141P	1000	
1	60287144P	65287143P	1250	
1	60287146P	65287145P	1600	
1	60287147P	65287146P	2000	
1	60397144P	65287148P	2500	
1	60397146P	65397145P	3200	
1	60397147P	65397146P	4000	
1	-	65397148P	5000	

**Single bar:**  
630A-2000A (Al)  
800A-2500A (Cu)

**Double bar:**  
2500A-4000A (Al)  
3200A-5000A (Cu)

## Super compact (SCP)

### straight elements (continued)

#### Dimensions

##### Phase balancing 1200 mm

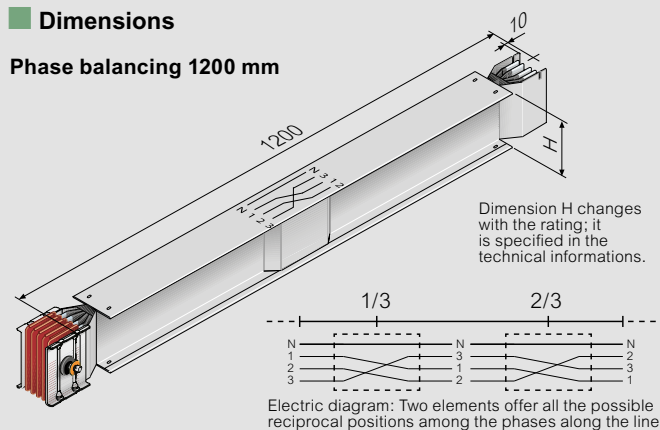

In particularly long carrying sections (> 100 metres) it is recommended to insert 2 elements always by 2: (one placed at 1/3 and one placed at 2/3 of the trunking path) to balance the electric impedance of the system

For example, in a line exceeding 300 m it is recommended that one phase transposition is fitted at 100 m, and another one at 200 m

##### Phase Inversion 1200 mm

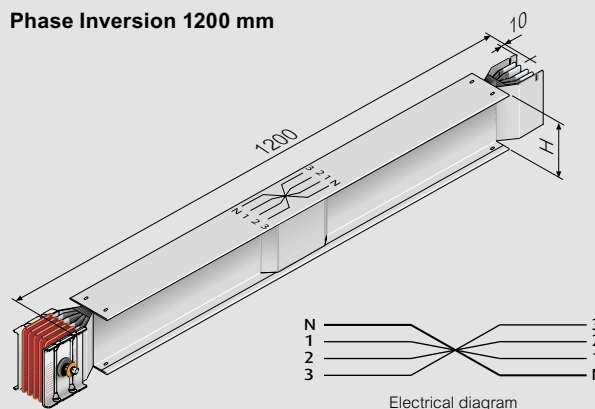

**Warning:** Use ONLY these elements for transport, and not for derivations (not use it when the line includes straight elements with derivations, or when they are provided for tap-off boxes even if bolted on the junction) The position of all the conductors, including the neutral, changes, and may cause serious problems on a connected load, if one is not fully aware that the phase sequence and the position of the neutral DO NOT comply with those indicated in the pre-printed labels

##### Element with neutral rotation 1000 mm

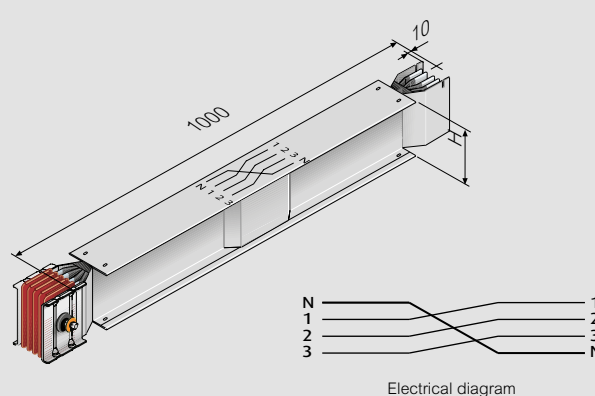

When the sequence of the distribution board phases is different from that of the transformer, it is possible to use an element that allows a neutral rotation

## Super compact (SCP)

### feed unit

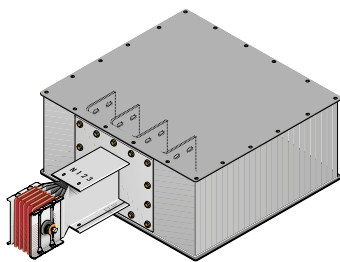

60281106P

The feed units are used at the end of the lines, when the busbar must be powered using cables. They are available in the right (without Monobloc) and left (with Monobloc fitted) version. On request they are available with non-standard execution. End feed units for single bar busbars are supplied with an aluminium blind back closing plate.

For double bar busbar trunking systems the plates are 2. Both versions are fitted with 2 extra side steel flanges and 2 inspection steel flanges (dark grey colour).

The cable is connected directly to the busbars using bolts. For more information on board/busbar connection see the tables below (Dimensions For The Box).

To feed the power supply cable through the back power supply flanges it will be necessary to drill a hole in case of single bar and two holes in case of double bar. The size of the holes is 170 x 410 mm.

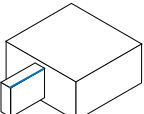
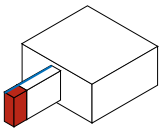
Pack	Cat.Nos		In (A)	Type
	Al	Cu		
1	60281100P	-	630	Right type 2 
1	60281101P	65281100P	800	
1	60281102P	65281101P	1000	
1	60281104P	65281103P	1250	
1	60281106P	65281105P	1600	
1	60281107P	65281106P	2000	
1	60391104P	65281108P	2500	
1	60391106P	65391105P	3200	
1	60391107P	65391106P	4000	
1	-	65391108P	5000	
1	60281110P	-	630	Left type 1 
1	60281111P	65281110P	800	
1	60281112P	65281111P	1000	
1	60281114P	65281113P	1250	
1	60281116P	65281115P	1600	
1	60281117P	65281116P	2000	
1	60391114P	65281118P	2500	
1	60391116P	65391115P	3200	
1	60391117P	65391116P	4000	
1	-	65391118P	5000	

## Super compact (SCP)

### feed unit

#### Dimensions

##### Feed unit

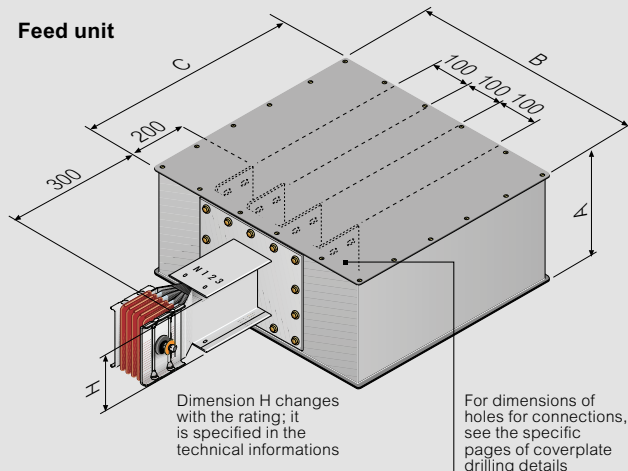

#### Rear cable input

Aluminium gland plate(s) for cable entry 170 x 410 mm

Single bar: 1 plate

Double bar: 2 plates

#### Dimensions FOR THE BOX

	630A÷1250A	1600÷2000A	2500A÷4000A
<b>Al</b>	630A÷1250A	1600A÷2500A	3200÷5000A
<b>Cu</b>	800A÷1250A	1600A÷2500A	3200÷5000A
(A) [mm]	320	320	600
(B) [mm]	600	600	600
(C) [mm]	610	810	810

Special dimensions (not standard) are available on request, please contact Legrand.

#### Type 2 (without monobloc)

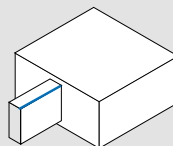

#### Type 1 (with monobloc)

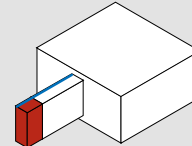

#### CONNECTIONS

Load (A)	The Copper (Cu) phase section is rounded up (mm <sup>2</sup> )	No. of connection holes for each busbar conductor	No. of one-pole cables that can be connected to each phase	
630	600	4	4x150	2x300
800				
1000				
1250	700	4	4x240	3x300
1600	850	8	4x240	3x300
2000	1100	8	5x240	4x300
2500	1400	8	6x240	5x300
3200	1700	16	8x240	6x300
4000	2100	16	9x240	7x300
5000	3000	16	14x240	10x300

# Super compact (SCP)

elbows

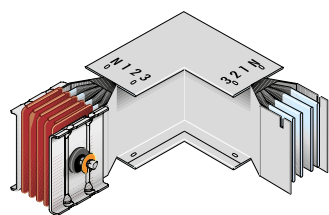

60280306P

Pack	Cat.Nos		Horizontal elbow		
	Al	Cu	In (A)	Type	Type
1	60280300P	-	630	Standard	
1	60280301P	65280300P	800		
1	60280302P	65280301P	1000		
1	60280304P	65280303P	1250		
1	60280306P	65280305P	1600		
1	60280307P	65280306P	2000		
1	60390304P	65280308P	2500		
1	60390306P	65390305P	3200		
1	60390307P	65390306P	4000		
1	-	65390308P	5000		
1	60280320P	-	630	Special	
1	60280321P	65280320P	800		
1	60280322P	65280321P	1000		
1	60280324P	65280323P	1250		
1	60280326P	65280325P	1600		
1	60280327P	65280326P	2000		
1	60390324P	65280328P	2500		
1	60390326P	65390325P	3200		
1	60390327P	65390326P	4000		
1	-	65390328P	5000		
1	60280310P	-	630	Standard	
1	60280311P	65280310P	800		
1	60280312P	65280311P	1000		
1	60280314P	65280313P	1250		
1	60280316P	65280315P	1600		
1	60280317P	65280316P	2000		
1	60390314P	65280318P	2500		
1	60390316P	65390315P	3200		
1	60390317P	65390316P	4000		
1	-	65390318P	5000		
1	60280330P	-	630	Special	
1	60280331P	65280330P	800		
1	60280332P	65280331P	1000		
1	60280334P	65280333P	1250		
1	60280336P	65280335P	1600		
1	60280337P	65280336P	2000		
1	60390334P	65280338P	2500		
1	60390336P	65390335P	3200		
1	60390337P	65390336P	4000		
1	-	65390338P	5000		

# Super compact (SCP)

elbows

## Dimensions

### Horizontal elbow

In order to define the type of horizontal elbow required, consider to place the element "edgewise" (conductors perpendicular to the ground). In this configuration "horizontal" elbows enable a path variation parallel to the ground. When the neutral busbar conductor faces the outside of the elbow, there will be a Right horizontal elbow (type 1). Contrariwise, with the neutral busbar conductor facing the inside of the elbow there will be a Left horizontal elbow (type 2).

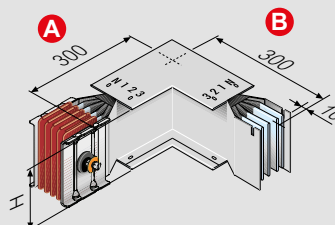
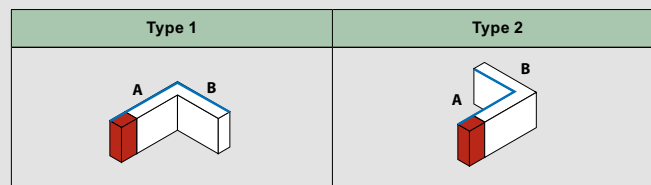

### MIN AND MAX DIMENSIONS OF SINGLE AND DOUBLE BAR

#### Single bar min/MAX

A	250/1299*
B	250/1299*

#### Double bar min/MAX

A	250/1299*
B	250/1299*

The dimensions are referred to the standard elements. Single/double bar (A+B): 300+300 mm

Dimension H changes with the rating; it is specified in the technical informations

No standard elements "Special" (with measurements that are different from those show in the figure) are referred to the Min and Max dimensions specified in the table

\* For all the non standard horizontal elbows (special), it is possible to have only one of the two sides in size exceeding 600 mm. For example, when ordering an horizontal elbow with size A=650 mm, the B size will have to be ≤ 600 mm

## Super compact (SCP)

### elbows (continued)

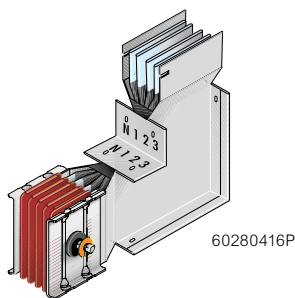

Pack	Cat.Nos		Vertical elbow		
	Al	Cu	In (A)	Type	Type
1	60280400P	-	630		Standard
1	60280401P	65280400P	800		
1	60280402P	65280401P	1000		
1	60280404P	65280403P	1250		
1	60280406P	65280405P	1600		
1	60280407P	65280406P	2000		
1	60390404P	65280408P	2500		
1	60390406P	65390405P	3200		
1	60390407P	65390406P	4000		
1	-	65390408P	5000		
1	60280420P	-	630	Right Type 2	Special
1	60280421P	65280420P	800		
1	60280422P	65280421P	1000		
1	60280424P	65280423P	1250		
1	60280426P	65280425P	1600		
1	60280427P	65280426P	2000		
1	60390424P	65280428P	2500		
1	60390426P	65390425P	3200		
1	60390427P	65390426P	4000		
1	-	65390428P	5000		
1	60280410P	-	630		Standard
1	60280411P	65280410P	800		
1	60280412P	65280411P	1000		
1	60280414P	65280413P	1250		
1	60280416P	65280415P	1600		
1	60280417P	65280416P	2000		
1	60390414P	65280418P	2500		
1	60390416P	65390415P	3200		
1	60390417P	65390416P	4000		
1	-	65390418P	5000		
1	60280430P	-	630	Left Type 1	Special
1	60280431P	65280430P	800		
1	60280432P	65280431P	1000		
1	60280434P	65280433P	1250		
1	60280436P	65280435P	1600		
1	60280437P	65280436P	2000		
1	60390434P	65280438P	2500		
1	60390436P	65390435P	3200		
1	60390437P	65390436P	4000		
1	-	65390438P	5000		

## Super compact (SCP)

### elbows (continued)

#### ■ Dimensions

##### Vertical elbow

In order to define the type of vertical elbow, it is necessary to still place the element "edgewise" (conductors perpendicular to the ground), with the section with Monobloc facing the observer and the section without facing up. In this configuration, vertical "elbows" enable an up or down facing variation. If the neutral is on the left side, there will be a left vertical elbow (Type 1). If, on the other side, it is on the right side, there will be a right vertical elbow (Type 2)

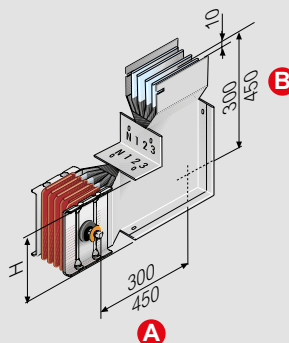
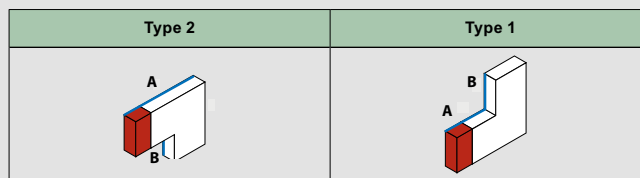

#### MIN AND MAX DIMENSIONS OF SINGLE AND DOUBLE BAR

##### Single bar min/MAX

A	300/1299*
B	300/1299*

##### Double bar min/MAX

A	430/1449*
B	430/1449*

Dimension H changes with the rating; it is specified in the technical informations

The dimensions are referred to the standard elements  
 single bar (A+B) : 300+300 mm  
 double bar (A+B) : 450+450 mm

No standard elements "Special" (with measurements that are different from those show in the figure) are referred to the Min and Max dimensions specified in the table

\* For all the non standard vertical elbows (special), it is possible to have only one of the two sides in size exceeding 600 mm. For example, when ordering a vertical elbow with size A=650 mm, the B size will have to be ≤ 600 mm

## Super compact (SCP)

elbows (continued)

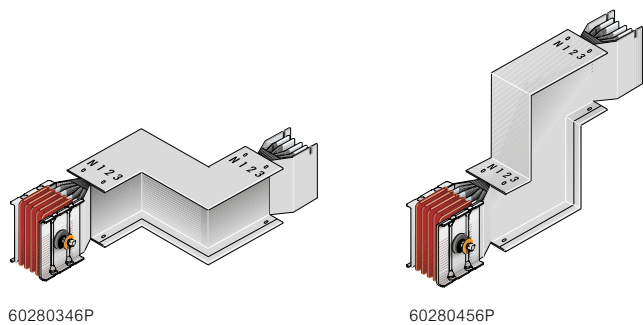

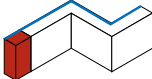
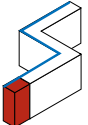
Pack	Cat.Nos		In (A)	Type
	Al	Cu		
1	60280340P	-	630	 Right Type 1
1	60280341P	65280340P	800	
1	60280342P	65280341P	1000	
1	60280344P	65280343P	1250	
1	60280346P	65280345P	1600	
1	60280347P	65280346P	2000	
1	60390344P	65280348P	2500	
1	60390346P	65390345P	3200	
1	60390347P	65390346P	4000	
1	-	65390348P	5000	
1	60280350P	-	630	 Left Type 2
1	60280351P	65280350P	800	
1	60280352P	65280351P	1000	
1	60280354P	65280353P	1250	
1	60280356P	65280355P	1600	
1	60280357P	65280356P	2000	
1	60390354P	65280358P	2500	
1	60390356P	65390355P	3200	
1	60390357P	65390356P	4000	
1	-	65390458P	5000	

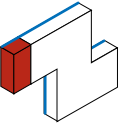
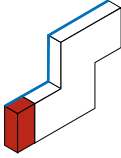
	Cat.Nos		In (A)	Type
	Al	Cu		
1	60280440P	-	630	 Right Type 2
1	60280441P	65280440P	800	
1	60280442P	65280441P	1000	
1	60280444P	65280443P	1250	
1	60280446P	65280445P	1600	
1	60280447P	65280446P	2000	
1	60390444P	65280448P	2500	
1	60390446P	65390445P	3200	
1	60390447P	65390446P	4000	
1	-	65390448P	5000	
1	60280450P	-	630	 Left Type 1
1	60280451P	65280450P	800	
1	60280452P	65280451P	1000	
1	60280454P	65280453P	1250	
1	60280456P	65280455P	1600	
1	60280457P	65280456P	2000	
1	60390454P	65280458P	2500	
1	60390456P	65390455P	3200	
1	60390457P	65390456P	4000	
1	-	65390458P	5000	

 **Single bar:**  
630A-2000A (Al)  
800A-2500A (Cu)

**Double bar:**  
2500A-4000A (Al)  
3200A-5000A (Cu)

## Super compact (SCP)

elbows (continued)

### ■ Dimensions

#### Double horizontal elbow

Double horizontal elbows are the union of two horizontal elbows; in order to define the type, it is enough to observe them starting from the Monobloc; if the first elbow met is left, we will have a double horizontal elbow left + right (Type 2). Contrariwise, if the first elbow met is right, we will have a double horizontal elbow right + left (Type 1)

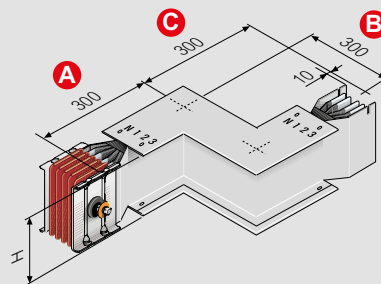

#### MIN AND MAX DIMENSIONS OF SINGLE AND DOUBLE BAR

Single bar min/MAX	
A	250/1299*
B	50/599*
C	250/1299*
Double bar min/MAX	
A	250/1299*
B	50/599*
C	250/1299*

The dimensions are referred to the standard elements.  
Single/double bar (A+B+C):  
300+300+300 mm

Dimension H changes with the rating; it is specified in the technical informations

Type 1	Type 2

#### Double vertical elbow

Double vertical elbows are the union of two vertical elbows; in order to define the type, it is enough to observe them starting from the Monobloc; if the first elbow met is left, we will have a double vertical elbow left + right (Type 1). Contrariwise, if the first elbow met is right, we will have a double vertical elbow right + left (Type 2)

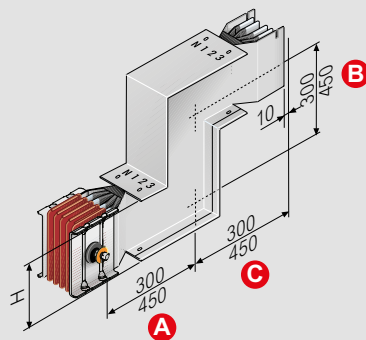

#### MIN AND MAX DIMENSIONS OF SINGLE AND DOUBLE BAR

Single bar min/MAX	
A	300/1299*
B	50/599*
C	300/1299*
Double bar min/MAX	
A	430/1449*
B	50/899*
C	430/1449*

The dimensions are referred to the standard elements.  
Single bar (A+B+C): 300+300+300 mm  
Double bar (A+B+C): 450+450+450 mm

Dimension H changes with the rating; it is specified in the technical informations

Type 2	Type 1

No standard elements "Special" (with measurements that are different from those show in the figure) are referred to the Min and Max dimensions specified in the table

\* For all the non standard double Horizontal or double Vertical elbows (special), it is possible to have only one of the three sides in size exceeding 600 mm

For example, when ordering a double horizontal or double vertical elbow with size A=650 mm, the B and C size will have to be ≤ 600 mm

## Super compact (SCP)

elbows (continued)

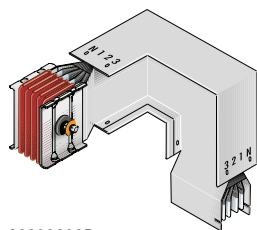

60280606P

Pack	Cat.Nos		In (A)	Type
	Al	Cu		
1	60280600P	-	630	<p>Type 1</p>
1	60280601P	65280600P	800	
1	60280602P	65280601P	1000	
1	60280604P	65280603P	1250	
1	60280606P	65280605P	1600	
1	60280607P	65280606P	2000	
1	60390604P	65280608P	2500	
1	60390606P	65390605P	3200	
1	60390607P	65390606P	4000	
1	-	65390608P	5000	
1	60280610P	-	630	<p>Type 2</p>
1	60280611P	65280610P	800	
1	60280612P	65280611P	1000	
1	60280614P	65280613P	1250	
1	60280616P	65280615P	1600	
1	60280617P	65280616P	2000	
1	60390614P	65280618P	2500	
1	60390616P	65390615P	3200	
1	60390617P	65390616P	4000	
1	-	65390618P	5000	
1	60280620P	-	630	<p>Type 3</p>
1	60280621P	65280620P	800	
1	60280622P	65280621P	1000	
1	60280624P	65280623P	1250	
1	60280626P	65280625P	1600	
1	60280627P	65280626P	2000	
1	60390624P	65280628P	2500	
1	60390626P	65390625P	3200	
1	60390627P	65390626P	4000	
1	-	65390628P	5000	
1	60280630P	-	630	<p>Type 4</p>
1	60280631P	65280630P	800	
1	60280632P	65280631P	1000	
1	60280634P	65280633P	1250	
1	60280636P	65280635P	1600	
1	60280637P	65280636P	2000	
1	60390634P	65280638P	2500	
1	60390636P	65390635P	3200	
1	60390637P	65390636P	4000	
1	-	65390638P	5000	

## Super compact (SCP)

elbows (continued)

### ■ Dimensions

#### Double elbow horizontal + vertical

Double elbows horizontal + vertical are the union of a horizontal and a vertical elbow, placed in succession starting from the side with Monobloc

Depending on the type of elbows, the double horizontal + vertical elbow may be of four different types:

- Double elbow Horizontal RH + Vertical RH (Type 1)
- Double elbow Horizontal RH + Vertical LH (Type 2)
- Double elbow Horizontal LH + Vertical RH (Type 3)
- Double elbow Horizontal LH + Vertical LH (Type 4)

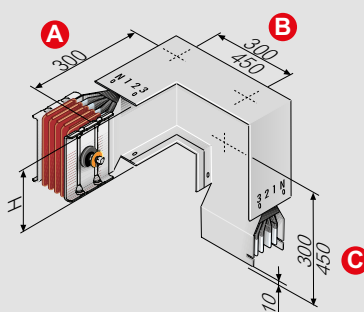
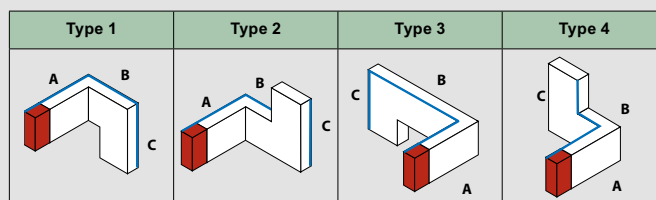

#### MIN AND MAX DIMENSIONS OF SINGLE AND DOUBLE BAR

Single bar min/MAX	
A	250/1299*
B	195/599*
C	300/1299*
Double bar min/MAX	
A	250/1499*
B	325/899*
C	430/1449*

The dimensions are referred to the standard elements  
 Single bar (A+B+C): 300+300+300 mm  
 double bar (A+B+C): 300+450+450 mm

Dimension H changes with the rating; it is specified in the technical informations

No standard elements "Special" (with measurements that are different from those show in the figure) are referred to the Min and Max dimensions specified in the table

\* For all the non standard double H+V elbow (special), it is possible to have only one of the three sides in size exceeding 600 mm. For example, when ordering a horizontal + vertical elbow with size A=650 mm, the B and C size will have to be ≤ 600 mm

**Note:**  
 RH - Right  
 LH - Left

## Super compact (SCP)

elbows (continued)

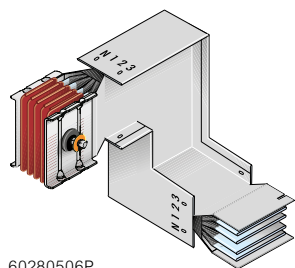

60280506P

Pack	Cat.Nos		In (A)	Type
	Al	Cu		
1	60280500P	-	630	<p>Type 1</p>
1	60280501P	65280500P	800	
1	60280502P	65280501P	1000	
1	60280504P	65280503P	1250	
1	60280506P	65280505P	1600	
1	60280507P	65280506P	2000	
1	60390504P	65280508P	2500	
1	60390506P	65390505P	3200	
1	60390507P	65390506P	4000	
1	-	65390508P	5000	
1	60280510P	-	630	<p>Type 2</p>
1	60280511P	65280510P	800	
1	60280512P	65280511P	1000	
1	60280514P	65280513P	1250	
1	60280516P	65280515P	1600	
1	60280517P	65280516P	2000	
1	60390514P	65280518P	2500	
1	60390516P	65390515P	3200	
1	60390517P	65390516P	4000	
1	-	65390518P	5000	
1	60280520P	-	630	<p>Type 3</p>
1	60280521P	65280520P	800	
1	60280522P	65280521P	1000	
1	60280524P	65280523P	1250	
1	60280526P	65280525P	1600	
1	60280527P	65280526P	2000	
1	60390524P	65280528P	2500	
1	60390526P	65390525P	3200	
1	60390527P	65390526P	4000	
1	-	65390528P	5000	
1	60280530P	-	630	<p>Type 4</p>
1	60280531P	65280530P	800	
1	60280532P	65280531P	1000	
1	60280534P	65280533P	1250	
1	60280536P	65280535P	1600	
1	60280537P	65280536P	2000	
1	60390534P	65280538P	2500	
1	60390536P	65390535P	3200	
1	60390537P	65390536P	4000	
1	-	65390538P	5000	

**Single bar:**  
630A-2000A (Al)  
800A-2500A (Cu)

**Double bar:**  
2500A-4000A (Al)  
3200A-5000A (Cu)

## Super compact (SCP)

elbows (continued)

### ■ Dimensions

#### Double elbow vertical + horizontal

Double elbows vertical + horizontal are the union of a vertical and a horizontal elbow, placed in succession starting from the side with Monobloc

Depending on the type of elbows, the double vertical + horizontal elbow may be of four different types:

- Double elbow vertical RH + horizontal RH (Type 1)
- Double elbow vertical RH + horizontal LH (Type 2)
- Double elbow vertical LH + horizontal RH (Type 3)
- Double elbow vertical LH + horizontal LH (Type 4)

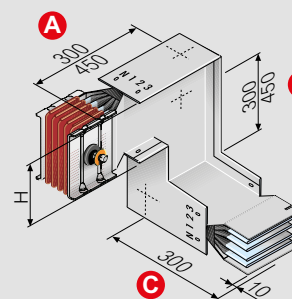
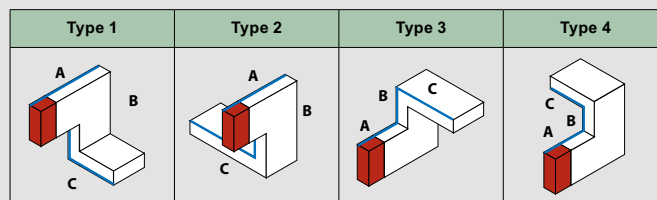

#### MIN AND MAX DIMENSIONS OF SINGLE AND DOUBLE BAR

Single bar min/MAX	
A	300/1299*
B	195/599*
C	250/1299*
Double bar min/MAX	
A	430/1449*
B	325/899*
C	250/1449*

Dimension H changes with the rating; it is specified in the technical informations

The dimensions are referred to the standard elements.

Single bar (A+B+C): 300+300+300 mm  
Double bar (A+B+C): 450+450+300 mm

No standard elements "Special" (with measurements that are different from those shown in the figure) are referred to the Min and Max dimensions specified in the table

\* For all the non standard double V+H elbows (special), it is possible to have only one of the three sides in size exceeding 600 mm. For example, when ordering a double vertical + horizontal elbow with size A=650 mm, the B and C size will have to be ≤ 600 mm

**Note:**  
RH - Right  
LH - Left

# Super compact (SCP)

## T elements

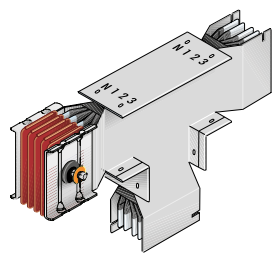

60280806P

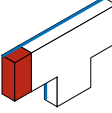
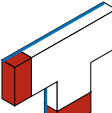
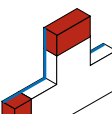
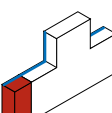
Pack	Cat.Nos		In (A)	Type
	Al	Cu		
1	60280800P	-	630	 Type 1
1	60280801P	65280800P	800	
1	60280802P	65280801P	1000	
1	60280804P	65280803P	1250	
1	60280806P	65280805P	1600	
1	60280807P	65280806P	2000	
1	60390804P	65280808P	2500	
1	60390806P	65390805P	3200	
1	60390807P	65390806P	4000	
1	-	65390808P	5000	
1	60280810P	-	630	 Type 2
1	60280811P	65280810P	800	
1	60280812P	65280811P	1000	
1	60280814P	65280813P	1250	
1	60280816P	65280815P	1600	
1	60280817P	65280816P	2000	
1	60390814P	65280818P	2500	
1	60390816P	65390815P	3200	
1	60390817P	65390816P	4000	
1	-	65390818P	5000	
1	60280820P	-	630	 Type 3
1	60280821P	65280820P	800	
1	60280822P	65280821P	1000	
1	60280824P	65280823P	1250	
1	60280826P	65280825P	1600	
1	60280827P	65280826P	2000	
1	60390824P	65280828P	2500	
1	60390826P	65390825P	3200	
1	60390827P	65390826P	4000	
1	-	65390828P	5000	
1	60280830P	-	630	 Type 4
1	60280831P	65280830P	800	
1	60280832P	65280831P	1000	
1	60280834P	65280833P	1250	
1	60280836P	65280835P	1600	
1	60280837P	65280836P	2000	
1	60390834P	65280838P	2500	
1	60390836P	65390835P	3200	
1	60390837P	65390836P	4000	
1	-	65390838P	5000	

# Super compact (SCP)

## T elements

### ■ Dimensions

#### Vertical T element

T-elements can be used to split the line in two branches, adding together the effect of two diverging elbows. There are four types of verticals "T" elements, as shown below

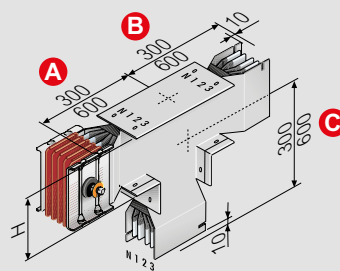
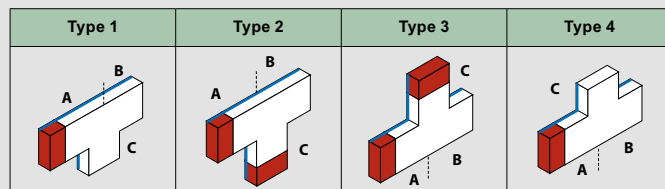

#### MIN AND MAX DIMENSIONS OF SINGLE AND DOUBLE BAR

##### Single bar min/MAX

A	300/1299*
B	300/1299*
C	300/1299*

##### Double bar min/MAX

A	450/1449*
B	450/1449*
C	450/1449*

Dimension H changes with the rating; it is specified in the technical informations

The dimensions are referred to the standard elements

Single bar (A+B+C): 300+300+300 mm  
 Double bar (A+B+C): 600+600+600 mm

No standard elements "Special" (with measurements that are different from those show in the figure) are referred to the Min and Max dimensions specified in the table

\* For all the non standard Vertical T elements (special), it is possible to have only one of the three sides in size exceeding 600 mm. For example, when ordering a T vertical element with size A=650 mm, the B and C size will have to be ≤600 mm

## Super compact (SCP)

### T elements (continued)

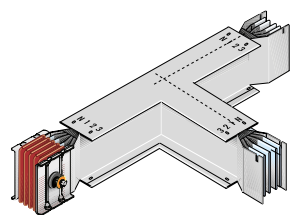

60280706P

Pack	Cat.Nos		In (A)	Type
	Al	Cu		
1	60280700P	-	630	 Type 1
1	60280701P	65280700P	800	
1	60280702P	65280701P	1000	
1	60280704P	65280703P	1250	
1	60280706P	65280705P	1600	
1	60280707P	65280706P	2000	
1	60390704P	65280708P	2500	
1	60390706P	65390705P	3200	
1	60390707P	65390706P	4000	
1	-	65390708P	5000	
1	60280710P	-	630	 Type 2
1	60280711P	65280710P	800	
1	60280712P	65280711P	1000	
1	60280714P	65280713P	1250	
1	60280716P	65280715P	1600	
1	60280717P	65280716P	2000	
1	60390714P	65280718P	2500	
1	60390716P	65390715P	3200	
1	60390717P	65390716P	4000	
1	-	65390718P	5000	
1	60280720P	-	630	 Type 3
1	60280721P	65280720P	800	
1	60280722P	65280721P	1000	
1	60280724P	65280723P	1250	
1	60280726P	65280725P	1600	
1	60280727P	65280726P	2000	
1	60390724P	65280728P	2500	
1	60390726P	65390725P	3200	
1	60390727P	65390726P	4000	
1	-	65390728P	5000	
1	60280730P	-	630	 Type 4
1	60280731P	65280730P	800	
1	60280732P	65280731P	1000	
1	60280734P	65280733P	1250	
1	60280736P	65280735P	1600	
1	60280737P	65280736P	2000	
1	60390734P	65280738P	2500	
1	60390736P	65390735P	3200	
1	60390737P	65390736P	4000	
1	-	65390738P	5000	

## Super compact (SCP)

### T elements (continued)

#### ■ Dimensions

#### Horizontal T element

T-elements can be used to split the line in two branches, adding together the effect of two diverging elbows. There are four types of horizontal "T" elements, as shown below

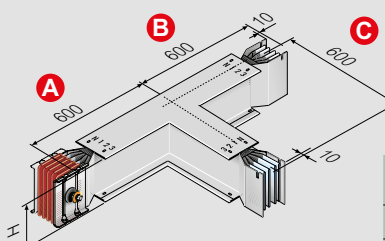
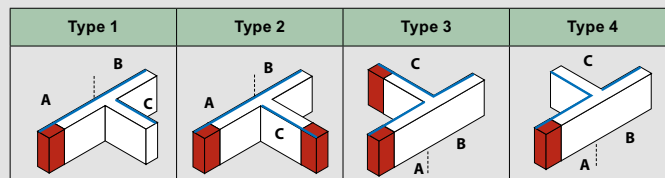

#### MIN AND MAX DIMENSIONS OF SINGLE AND DOUBLE BAR

##### Single bar min/MAX

Dimension	Value
A	600/1449*
B	600/1449*
C	600/1449*

##### Double bar min/MAX

Dimension	Value
A	600/1449*
B	600/1449*
C	600/1449*

Dimension H changes with the rating; it is specified in the technical informations

The dimensions are referred to the standard elements. Single/double bar (A+B+C): 600+600+600 mm

No standard elements "Special" (with measurements that are different from those shown in the figure) are referred to the Min and Max dimensions specified in the table

\* For all the non standard Horizontal T elements (special), it is possible to have only one of the three sides in size exceeding 600 mm. For example, when ordering a T horizontal element with size A=650 mm, the B and C size will have to be ≤ 600 mm

#### Note:

Only in special cases, where it is not possible to use the standard element, it is possible to have only one of three arms with minimum dimension of 300mm.

For more informations please contact Legrand

# Super compact (SCP)

connection interfaces with exit bars

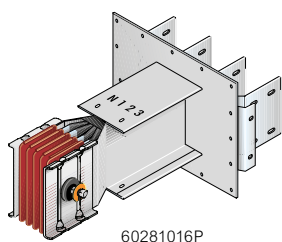

60281016P

Pack	Cat.Nos		Connection interfaces with exit bars		
	Al	Cu	In (A)	Type	Type
1	60281000P	-	630	Standard	Standard
1	60281001P	65281000P	800		
1	60281002P	65281001P	1000		
1	60281004P	65281003P	1250		
1	60281006P	65281005P	1600		
1	60281007P	65281006P	2000		
1	60391004P	65281008P	2500		
1	60391006P	65391005P	3200		
1	60391007P	65391006P	4000		
1	-	65391008P	5000		
1	60281020P	-	630	Special	Right Type 2
1	60281021P	65281020P	800		
1	60281022P	65281021P	1000		
1	60281024P	65281023P	1250		
1	60281026P	65281025P	1600		
1	60281027P	65281026P	2000		
1	60391024P	65281028P	2500		
1	60391026P	65391025P	3200		
1	60391027P	65391026P	4000		
1	-	65391028P	5000		
1	60281010P	-	630	Standard	Standard
1	60281011P	65281010P	800		
1	60281012P	65281011P	1000		
1	60281014P	65281013P	1250		
1	60281016P	65281015P	1600		
1	60281017P	65281016P	2000		
1	60391014P	65281018P	2500		
1	60391016P	65391015P	3200		
1	60391017P	65391016P	4000		
1	-	65391018P	5000		
1	60281030P	-	630	Special	Left Type 1
1	60281031P	65281030P	800		
1	60281032P	65281031P	1000		
1	60281034P	65281033P	1250		
1	60281036P	65281035P	1600		
1	60281037P	65281036P	2000		
1	60391034P	65281038P	2500		
1	60391036P	65391035P	3200		
1	60391037P	65391036P	4000		
1	-	65391038P	5000		

# Super compact (SCP)

connection interfaces with exit bars

## Dimensions

### Connection interfaces with exit bars

Standard connection interfaces are used at the end of the lines to connect the busbar to boards or transformers. They are available in the right (without Monobloc) and left (with Monobloc fitted) version. The drawings below refer to the standard versions. Different executions are available on request (e.g.: length, centre distance between bar conductors, drilling, etc.)

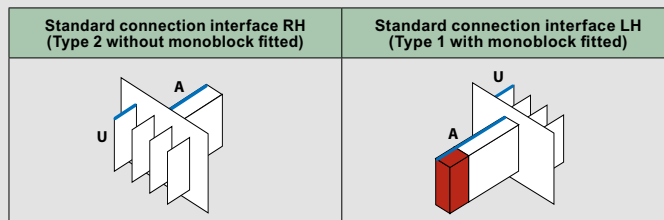

**Note:**  
RH - Right  
LH - Left

### Standard connection interface

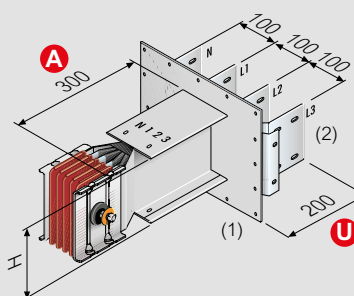

See on page 104 the drawings with all drilling details for dimensions of coverplate (1) and bars (2)

#### MIN AND MAX DIMENSIONS OF SINGLE AND DOUBLE BAR

Single bar min/MAX	
U	150/400
A	200/1299
Double bar min/MAX	
U	150/400
A	200/1299

Dimension H changes with the rating; it is specified in the technical informations

The dimensions are referred to the standard elements.  
Single/double bar (U+A):  
200+300 mm

No standard elements "Special" (with measurements that are different from those show in the figure) are referred to the Min and Max dimensions specified in the table

On request is available the busbar connection interface with exit bars for range:

**Al:** 5000A  
**Cu:** 6300A

### Special connection interface with interaxes not standard

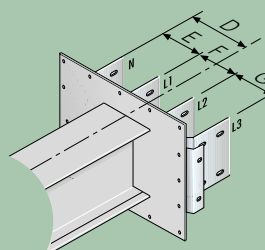

Dimensioning indications to be provided when using a non-standard centre distance

# Super compact (SCP)

## dimensions

### Coverplate drilling details (1)

**Al** 630A÷2000A  
**Cu** 800A÷2500A

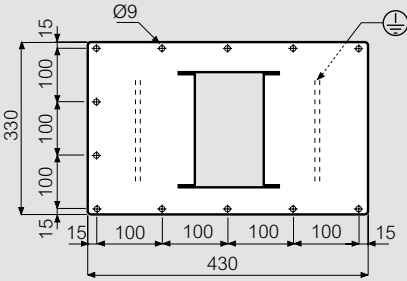

**Al** 2500A÷3200A  
**Cu** 3200A÷4000A

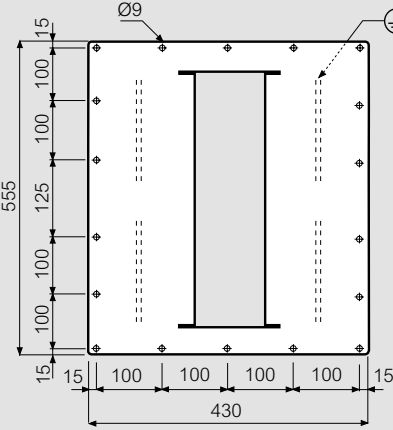

**Al** 4000A  
**Cu** 5000A

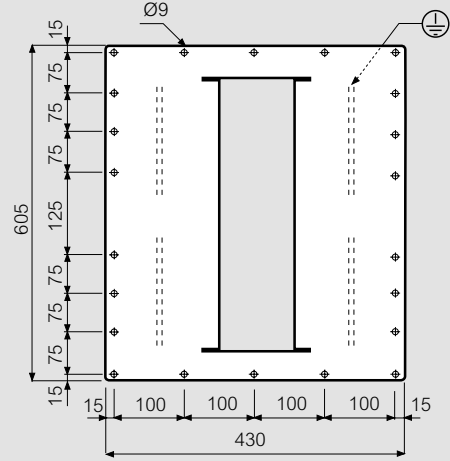

### Bar drilling details (2)

**Al** 630A  
**Cu** 800A

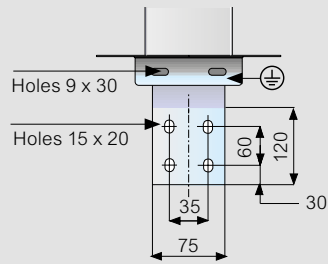

**Al** 800A-1000A  
**Cu** 1000A-1250A

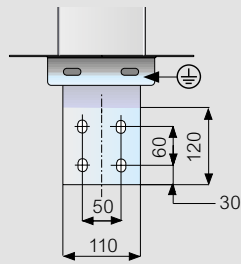

**Al** 1250A

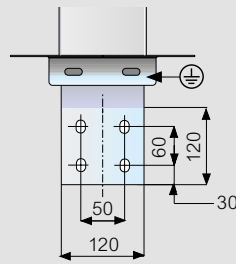

**Al** 1600A

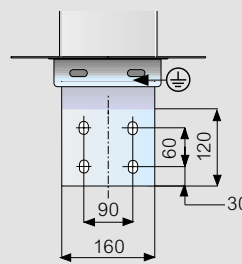

**Cu** 1600A

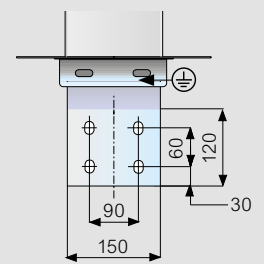

**Al** 2000A

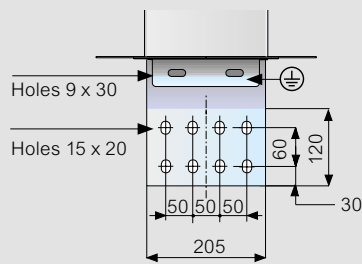

**Cu** 2000A

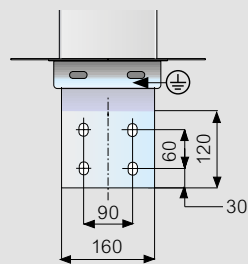

**Cu** 2500A

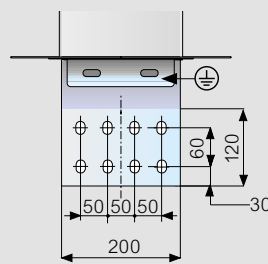

**Al** 2500A  
**Cu** 3200A

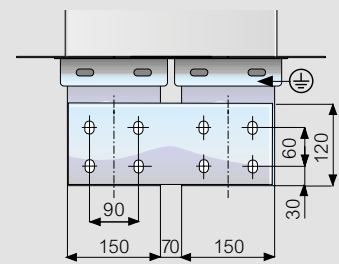

**Al** 3200A  
**Cu** 4000A

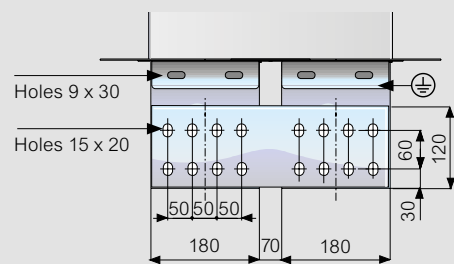

**Al** 4000A

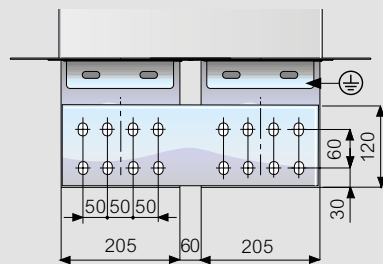

**Cu** 5000A

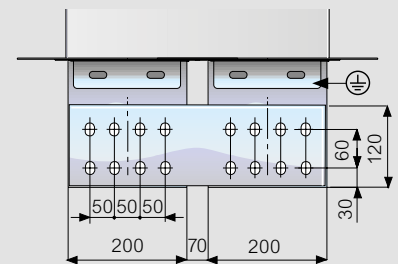

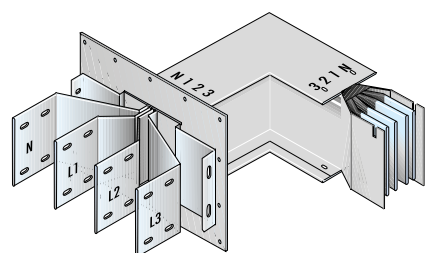

## Super compact (SCP)

connection interfaces with exit bars + horizontal elbow

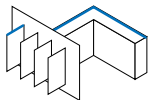
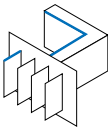
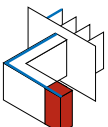

60281306P

Pack	Cat.Nos		In (A)	Type
	Al	Cu		
1	60281300P	-	630	 Type 1
1	60281301P	65281300P	800	
1	60281302P	65281301P	1000	
1	60281304P	65281303P	1250	
1	60281306P	65281305P	1600	
1	60281307P	65281306P	2000	
1	60391304P	65281308P	2500	
1	60391306P	65391305P	3200	
1	60391307P	65391306P	4000	
1	-	65391308P	5000	
1	60281310P	-	630	 Type 2
1	60281311P	65281310P	800	
1	60281312P	65281311P	1000	
1	60281314P	65281313P	1250	
1	60281316P	65281315P	1600	
1	60281317P	65281316P	2000	
1	60391314P	65281318P	2500	
1	60391316P	65391315P	3200	
1	60391317P	65391316P	4000	
1	-	65391318P	5000	
1	60281320P	-	630	 Type 3
1	60281321P	65281320P	800	
1	60281322P	65281321P	1000	
1	60281324P	65281323P	1250	
1	60281326P	65281325P	1600	
1	60281327P	65281326P	2000	
1	60391324P	65281328P	2500	
1	60391326P	65391325P	3200	
1	60391327P	65391326P	4000	
1	-	65391328P	5000	
1	60281330P	-	630	 Type 4
1	60281331P	65281330P	800	
1	60281332P	65281331P	1000	
1	60281334P	65281333P	1250	
1	60281336P	65281335P	1600	
1	60281337P	65281336P	2000	
1	60391334P	65281338P	2500	
1	60391336P	65391335P	3200	
1	60391337P	65391336P	4000	
1	-	65391338P	5000	

 **Single bar:**  
630A-2000A (Al)  
800A-2500A (Cu)

**Double bar:**  
2500A-4000A (Al)  
3200A-5000A (Cu)

## Super compact (SCP)

connection interfaces with exit bars + horizontal elbow

### Dimensions

#### Connection interfaces with exit bars + horizontal elbow

This element is the union of a connection interface with exit bars and a horizontal elbow

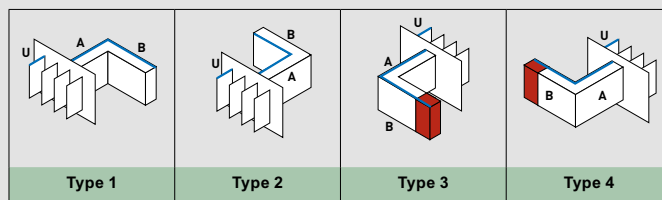

The dimensions are referred to the standard elements

Single/double bar (U+A+B): 200+300+300 mm

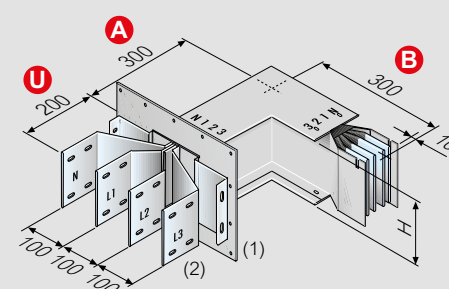

#### MIN AND MAX DIMENSIONS OF SINGLE AND DOUBLE BAR

Single bar min/MAX	
U	150/400
A	115/1299*
B	250/1299*
Double bar min/MAX	
U	150/400
A	115/1299*
B	250/1299*

See on page 104 the drawings with all drilling details for dimensions of coverplate (1) and bars (2)

Dimension H changes with the rating; it is specified in the technical informations

No standard elements "Special" (with measurements that are different from those show in the figure) are referred to the Min and Max dimensions specified in the table

\* For all the non standard connection interface with exit bars + horizontal elbows (special), it is possible to have only one of the two sides in size exceeding 600 mm

For example, when ordering an interface with exit bars + horizontal elbow with size A=650 mm, the B size will have to be ≤ 600 mm

## Super compact (SCP) - connection interfaces

with exit bars + vertical elbow

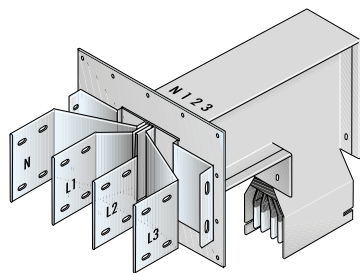

60281406P

Pack	Cat.Nos		In (A)	Type
	Al	Cu		
1	60281400P	-	630	<p>Type 1</p>
1	60281401P	65281400P	800	
1	60281402P	65281401P	1000	
1	60281404P	65281403P	1250	
1	60281406P	65281405P	1600	
1	60281407P	65281406P	2000	
1	60391404P	65281408P	2500	
1	60391406P	65391405P	3200	
1	60391407P	65391406P	4000	
1	-	65391408P	5000	
1	60281410P	-	630	<p>Type 2</p>
1	60281411P	65281410P	800	
1	60281412P	65281411P	1000	
1	60281414P	65281413P	1250	
1	60281416P	65281415P	1600	
1	60281417P	65281416P	2000	
1	60391414P	65281418P	2500	
1	60391416P	65391415P	3200	
1	60391417P	65391416P	4000	
1	-	65391418P	5000	
1	60281420P	-	630	<p>Type 3</p>
1	60281421P	65281420P	800	
1	60281422P	65281421P	1000	
1	60281424P	65281423P	1250	
1	60281426P	65281425P	1600	
1	60281427P	65281426P	2000	
1	60391424P	65281428P	2500	
1	60391426P	65391425P	3200	
1	60391427P	65391426P	4000	
1	-	65391428P	5000	
1	60281430P	-	630	<p>Type 4</p>
1	60281431P	65281430P	800	
1	60281432P	65281431P	1000	
1	60281434P	65281433P	1250	
1	60281436P	65281435P	1600	
1	60281437P	65281436P	2000	
1	60391434P	65281438P	2500	
1	60391436P	65391435P	3200	
1	60391437P	65391436P	4000	
1	-	65391438P	5000	

**Single bar:**  
630A-2000A (Al)  
800A-2500A (Cu)

**Double bar:**  
2500A-4000A (Al)  
3200A-5000A (Cu)

## Super compact (SCP) - connection interfaces

with exit bars + vertical elbow

### Dimensions

#### Connection interfaces with exit bars + vertical elbow

This element is the union of a connection interface with exit bars and a vertical elbow

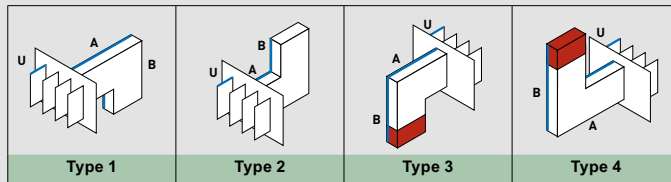

The dimensions are referred to the standard elements

Single bar (U+A+B): 200+300+300 mm  
Double bar (U+A+B): 200+450+450 mm

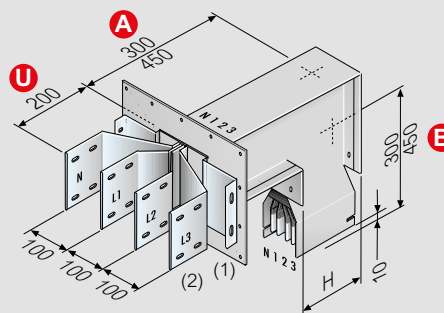

#### MIN AND MAX DIMENSIONS OF SINGLE AND DOUBLE BAR

Single bar min/MAX	
U	150/400
A	160/1299*
B	300/1299*
Double bar min/MAX	
U	150/400
A	290/1449*
B	430/1449*

See on page 104 the drawings with all drilling details for dimensions of coverplate (1) and bars (2)

Dimension H changes with the rating; it is specified in the technical informations

No standard elements "Special" (with measurements that are different from those show in the figure) are referred to the Min and Max dimensions specified in the table



\* For all the non standard connection interface with exit bars + vertical elbows (special), it is possible to have only one of the two sides in size exceeding 600 mm  
For example, when ordering an interface with exit bars + vertical elbow with size A=650 mm, the B size will have to be ≤ 600 mm

## Super compact (SCP)

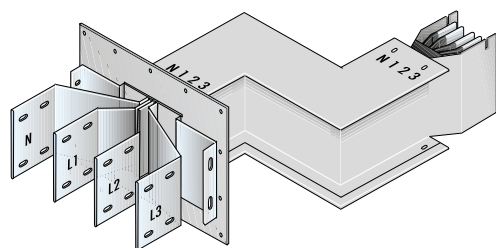
connection interfaces with exit bars + double horizontal elbow

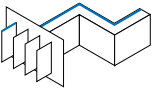
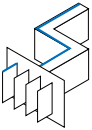

60281346P

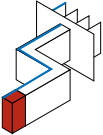
Pack	Cat.Nos		In (A)	Type
	Al	Cu		
1	60281340P	-	630	 Type 1
1	60281341P	65281340P	800	
1	60281342P	65281341P	1000	
1	60281344P	65281343P	1250	
1	60281346P	65281345P	1600	
1	60281347P	65281346P	2000	
1	60391344P	65281348P	2500	
1	60391346P	65391345P	3200	
1	60391347P	65391346P	4000	
1	-	65391348P	5000	
1	60281350P	-	630	 Type 2
1	60281351P	65281350P	800	
1	60281352P	65281351P	1000	
1	60281354P	65281353P	1250	
1	60281356P	65281355P	1600	
1	60281357P	65281356P	2000	
1	60391354P	65281358P	2500	
1	60391356P	65391355P	3200	
1	60391357P	65391356P	4000	
1	-	65391358P	5000	
1	60281360P	-	630	 Type 3
1	60281361P	65281360P	800	
1	60281362P	65281361P	1000	
1	60281364P	65281363P	1250	
1	60281366P	65281365P	1600	
1	60281367P	65281366P	2000	
1	60391364P	65281368P	2500	
1	60391366P	65391365P	3200	
1	60391367P	65391366P	4000	
1	-	65391368P	5000	
1	60281370P	-	630	 Type 4
1	60281371P	65281370P	800	
1	60281372P	65281371P	1000	
1	60281374P	65281373P	1250	
1	60281376P	65281375P	1600	
1	60281377P	65281376P	2000	
1	60391374P	65281378P	2500	
1	60391376P	65391375P	3200	
1	60391377P	65391376P	4000	
1	-	65391378P	5000	

## Super compact (SCP)

connection interfaces with exit bars + double horizontal elbow

### ■ Dimensions

#### Connection interfaces with exit bars + double horizontal elbow

This element is the union of a connection interface with exit bars and a two horizontal elbows

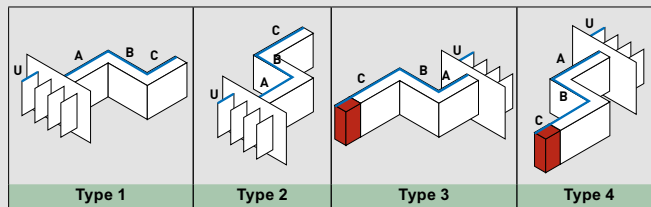

The dimensions are referred to the standard elements

Single bar (U+A+B+C): 200+300+300+300 mm  
 Double bar (U+A+B+C): 200+450+300+450 mm

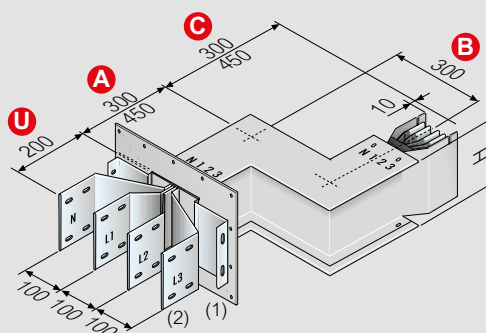

#### MIN AND MAX DIMENSIONS OF SINGLE AND DOUBLE BAR

Single bar min/MAX	
U	150/400
A	115/599
B	50/599
C	250/1299
Double bar min/MAX	
U	150/400
A	115/599
B	50/599
C	250/1299

See on page 104 the drawings with all drilling details for dimensions of coverplate (1) and bars (2)

Dimension H changes with the rating; it is specified in the technical informations

No standard elements "Special" (with measurements that are different from those show in the figure) are referred to the Min and Max dimensions specified in the table

## Super compact (SCP)

connection interfaces with exit bars + double vertical elbow

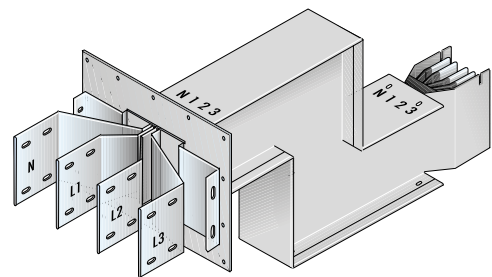

60281446P

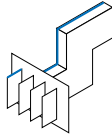
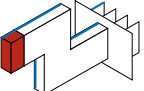
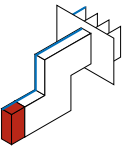
Pack	Cat.Nos		In (A)	Type
	Al	Cu		
1	60281440P	-	630	 Type 1
1	60281441P	65281440P	800	
1	60281442P	65281441P	1000	
1	60281444P	65281443P	1250	
1	60281446P	65281445P	1600	
1	60281447P	65281446P	2000	
1	60391444P	65281448P	2500	
1	60391446P	65391445P	3200	
1	60391447P	65391446P	4000	
1	-	65391448P	5000	
1	60281450P	-	630	 Type 2
1	60281451P	65281450P	800	
1	60281452P	65281451P	1000	
1	60281454P	65281453P	1250	
1	60281456P	65281455P	1600	
1	60281457P	65281456P	2000	
1	60391454P	65281458P	2500	
1	60391456P	65391455P	3200	
1	60391457P	65391456P	4000	
1	-	65391458P	5000	
1	60281460P	-	630	 Type 3
1	60281461P	65281460P	800	
1	60281462P	65281461P	1000	
1	60281464P	65281463P	1250	
1	60281466P	65281465P	1600	
1	60281467P	65281466P	2000	
1	60391464P	65281468P	2500	
1	60391466P	65391465P	3200	
1	60391467P	65391466P	4000	
1	-	65391468P	5000	
1	60281470P	-	630	 Type 4
1	60281471P	65281470P	800	
1	60281472P	65281471P	1000	
1	60281474P	65281473P	1250	
1	60281476P	65281475P	1600	
1	60281477P	65281476P	2000	
1	60391474P	65281478P	2500	
1	60391476P	65391475P	3200	
1	60391477P	65391476P	4000	
1	-	65391478P	5000	

 **Single bar:**  
630A-2000A (Al)  
800A-2500A (Cu)

**Double bar:**  
2500A-4000A (Al)  
3200A-5000A (Cu)

## Super compact (SCP)

connection interfaces with exit bars + double vertical elbow

### ■ Dimensions

#### Connection interfaces with exit bars + double vertical elbow

This element is the union of a connection interface with exit bars and a two vertical elbows

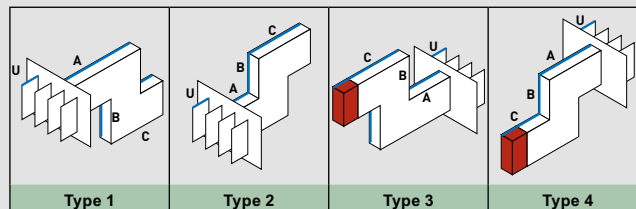

The dimensions are referred to the standard elements

Single bar (U+A+B+C): 200+300+300+300 mm  
Double bar (U+A+B+C): 200+450+450+450 mm

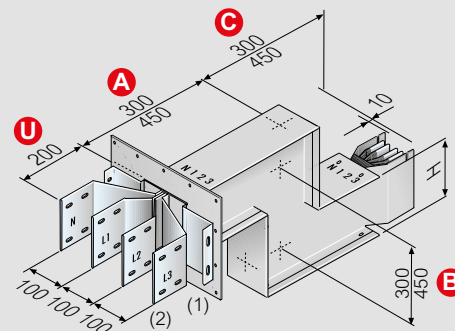

#### MIN AND MAX DIMENSIONS OF SINGLE AND DOUBLE BAR

Single bar min/MAX	
U	150/400
A	160/599
B	50/599
C	300/1299
Double bar min/MAX	
U	150/400
A	290/599*
B	50/899*
C	430/1449*

See on page 104 the drawings with all drilling details for dimensions of coverplate (1) and bars (2)

Dimension H changes with the rating; it is specified in the technical informations

No standard elements "Special" (with measurements that are different from those show in the figure) are referred to the Min and Max dimensions specified in the table

\* For all the non standard connection interface with exit bars + double vertical elbows (special), it is possible to have only one of the three sides in size exceeding 600 mm  
For example, when ordering a connection interface with exit bars + double vertical elbow with size C=650 mm, the A and B size will have to be ≤600 mm

# Super compact (SCP)

connection interfaces with exit bars + vertical elbow + horizontal elbow

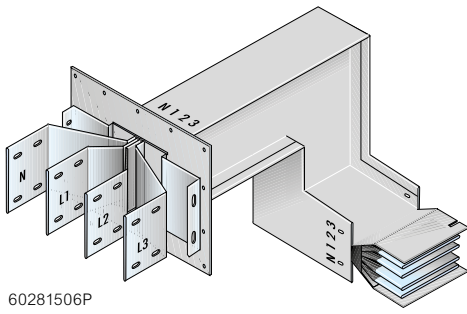

60281506P

Pack	Cat.Nos		In (A)	Type
	Al	Cu		
1	60281500P	-	630	<p>Type 1</p>
1	60281501P	65281500P	800	
1	60281502P	65281501P	1000	
1	60281504P	65281503P	1250	
1	60281506P	65281505P	1600	
1	60281507P	65281506P	2000	
1	60391504P	65281508P	2500	
1	60391506P	65391505P	3200	
1	60391507P	65391506P	4000	
1	-	65391508P	5000	
1	60281510P	-	630	
1	60281511P	65281510P	800	
1	60281512P	65281511P	1000	
1	60281514P	65281513P	1250	
1	60281516P	65281515P	1600	
1	60281517P	65281516P	2000	
1	60391514P	65281518P	2500	
1	60391516P	65391515P	3200	
1	60391517P	65391516P	4000	
1	-	65391518P	5000	
1	60281520P	-	630	<p>Type 3</p>
1	60281521P	65281520P	800	
1	60281522P	65281521P	1000	
1	60281524P	65281523P	1250	
1	60281526P	65281525P	1600	
1	60281527P	65281526P	2000	
1	60391524P	65281528P	2500	
1	60391526P	65391525P	3200	
1	60391527P	65391526P	4000	
1	-	65391528P	5000	
1	60281530P	-	630	
1	60281531P	65281530P	800	
1	60281532P	65281531P	1000	
1	60281534P	65281533P	1250	
1	60281536P	65281535P	1600	
1	60281537P	65281536P	2000	
1	60391534P	65281538P	2500	
1	60391536P	65391535P	3200	
1	60391537P	65391536P	4000	
1	-	65391538P	5000	
1	60281540P	-	630	<p>Type 5</p>
1	60281541P	65281540P	800	
1	60281542P	65281541P	1000	
1	60281544P	65281543P	1250	
1	60281546P	65281545P	1600	
1	60281547P	65281546P	2000	
1	60391544P	65281548P	2500	
1	60391546P	65391545P	3200	
1	60391547P	65391546P	4000	
1	-	65391548P	5000	

Pack	Cat.Nos		In (A)	Type
	Al	Cu		
1	60281550P	-	630	<p>Type 6</p>
1	60281551P	65281550P	800	
1	60281552P	65281551P	1000	
1	60281554P	65281553P	1250	
1	60281556P	65281555P	1600	
1	60281557P	65281556P	2000	
1	60391554P	65281558P	2500	
1	60391556P	65391555P	3200	
1	60391557P	65391556P	4000	
1	-	65391558P	5000	
1	60281560P	-	630	
1	60281561P	65281560P	800	
1	60281562P	65281561P	1000	
1	60281564P	65281563P	1250	
1	60281566P	65281565P	1600	
1	60281567P	65281566P	2000	
1	60391564P	65281568P	2500	
1	60391566P	65391565P	3200	
1	60391567P	65391566P	4000	
1	-	65391568P	5000	
1	60281570P	-	630	<p>Type 8</p>
1	60281571P	65281570P	800	
1	60281572P	65281571P	1000	
1	60281574P	65281573P	1250	
1	60281576P	65281575P	1600	
1	60281577P	65281576P	2000	
1	60391574P	65281578P	2500	
1	60391576P	65391575P	3200	
1	60391577P	65391576P	4000	
1	-	65391578P	5000	

# Super compact (SCP)

connection interfaces with exit bars + horizontal elbow + vertical elbow

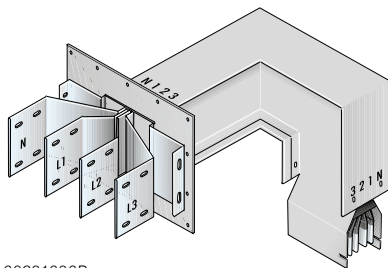

60281606P

Pack	Cat.Nos		In (A)	Type	Pack	Cat.Nos		In (A)	Type
	Al	Cu				Al	Cu		
1	60281600P	-	630	 Type 1	1	60281650P	-	630	 Type 6
1	60281601P	65281600P	800		1	60281651P	65281650P	800	
1	60281602P	65281601P	1000		1	60281652P	65281651P	1000	
1	60281604P	65281603P	1250		1	60281654P	65281653P	1250	
1	60281606P	65281605P	1600		1	60281656P	65281655P	1600	
1	60281607P	65281606P	2000		1	60281657P	65281656P	2000	
1	60391604P	65281608P	2500		1	60391654P	65281658P	2500	
1	60391606P	65391605P	3200		1	60391656P	65391655P	3200	
1	60391607P	65391606P	4000		1	60391657P	65391656P	4000	
1	-	65391608P	5000		1	-	65391658P	5000	
1	60281610P	-	630	 Type 2	1	60281660P	-	630	 Type 7
1	60281611P	65281610P	800		1	60281661P	65281660P	800	
1	60281612P	65281611P	1000		1	60281662P	65281661P	1000	
1	60281614P	65281613P	1250		1	60281664P	65281663P	1250	
1	60281616P	65281615P	1600		1	60281666P	65281665P	1600	
1	60281617P	65281616P	2000		1	60281667P	65281666P	2000	
1	60391614P	65281618P	2500		1	60391664P	65281668P	2500	
1	60391616P	65391615P	3200		1	60391666P	65391665P	3200	
1	60391617P	65391616P	4000		1	60391667P	65391666P	4000	
1	-	65391518P	5000		1	-	65391668P	5000	
1	60281620P	-	630	 Type 3	1	60281670P	-	630	 Type 8
1	60281621P	65281620P	800		1	60281671P	65281670P	800	
1	60281622P	65281621P	1000		1	60281672P	65281671P	1000	
1	60281624P	65281623P	1250		1	60281674P	65281673P	1250	
1	60281626P	65281625P	1600		1	60281676P	65281675P	1600	
1	60281627P	65281626P	2000		1	60281677P	65281676P	2000	
1	60391624P	65281628P	2500		1	60391674P	65281678P	2500	
1	60391626P	65391625P	3200		1	60391676P	65391675P	3200	
1	60391627P	65391626P	4000		1	60391677P	65391676P	4000	
1	-	65391628P	5000		1	-	65391678P	5000	
1	60281630P	-	630	 Type 4	1	60281640P	-	630	 Type 5
1	60281631P	65281630P	800		1	60281641P	65281640P	800	
1	60281632P	65281631P	1000		1	60281642P	65281641P	1000	
1	60281634P	65281633P	1250		1	60281644P	65281643P	1250	
1	60281636P	65281635P	1600		1	60281646P	65281645P	1600	
1	60281637P	65281636P	2000		1	60281647P	65281646P	2000	
1	60391634P	65281638P	2500		1	60391644P	65281648P	2500	
1	60391636P	65391635P	3200		1	60391646P	65391645P	3200	
1	60391637P	65391636P	4000		1	60391647P	65391646P	4000	
1	-	65391638P	5000		1	-	65391648P	5000	



**Single bar:**  
630A-2000A (Al)  
800A-2500A (Cu)

**Double bar:**  
2500A-4000A (Al)  
3200A-5000A (Cu)

## Super compact (SCP) - connection interfaces with exit bars + vertical elbow + horizontal elbow

## Super compact (SCP) - connection interfaces with exit bars + horizontal elbow + vertical elbow

### ■ Dimensions

#### Connection interfaces with exit bars + vertical elbow + horizontal elbow

This element is the union of a connection interface with exit bars and a vertical and horizontal elbow

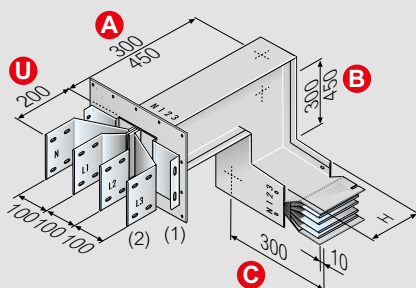

The dimensions are referred to the standard elements.  
 Single bar (U+A+B+C):  
 200+300+300+300 mm  
 Double bar (U+A+B+C):  
 200+450+450+300 mm

No standard elements "Special" (with measurements that are different from those show in the figure) are referred to the Min and Max dimensions specified in the table

\* For all the non standard connection interface with exit bars + vertical elbows + horizontal elbow (special), it is possible to have only one of the three sides in size exceeding 600 mm. For example, when ordering a connection interface with exit bars + vertical elbow + horizontal elbow with size C=650 mm, the A and B size will have to be ≤ 600 mm

MIN AND MAX DIMENSIONS OF SINGLE AND DOUBLE BAR	
Single bar min/MAX	
U	150/400
A	160/599
B	195/599
C	250/1299
Double bar min/MAX	
U	150/400
A	290/749*
B	325/749*
C	250/1449*

See on page 104 the drawings with all drilling details for dimensions of coverplate (1) and bars (2)

Dimension H changes with the rating; it is specified in the technical informations

### ■ Dimensions

#### Connection interfaces with exit bars + horizontal elbow + vertical elbow

This element is the union of a connection interface with exit bars and a horizontal and vertical elbow

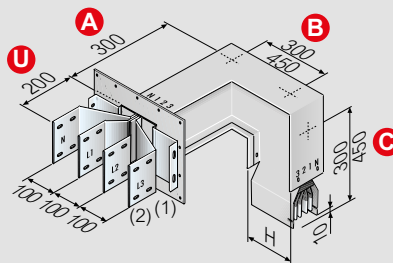

The dimensions are referred to the standard elements.  
 Single bar (U+A+B+C):  
 200+300+300+300 mm  
 Double bar (U+A+B+C):  
 200+300+450+450 mm

No standard elements "Special" (with measurements that are different from those show in the figure) are referred to the Min and Max dimensions specified in the table.

\* For all the non standard connection interface with exit bars + horizontal elbow + vertical elbow (special), it is possible to have only one of the three sides in size exceeding 600 mm. For example, when ordering a connection interface with exit bars + horizontal elbow + vertical elbow with size C=650 mm, the A and B size will have to be ≤ 600 mm

MIN AND MAX DIMENSIONS OF SINGLE AND DOUBLE BAR	
Single bar min/MAX	
U	150/400
A	115/599
B	195/599
C	300/1299
Double bar min/MAX	
U	150/400
A	115/599*
B	325/749*
C	430/1449*

See on Pag.(104) the drawings with all drilling details for dimensions of coverplate (1) and bars (2)

Dimension H changes with the rating; it is specified in the technical informations

# Super compact (SCP)

complementary run components

SELECTION ISOLATOR AND RATE REDUCER WITH ISOLATOR SWITCH

The type of route:

- 1) Edgewise
- 2) Flat

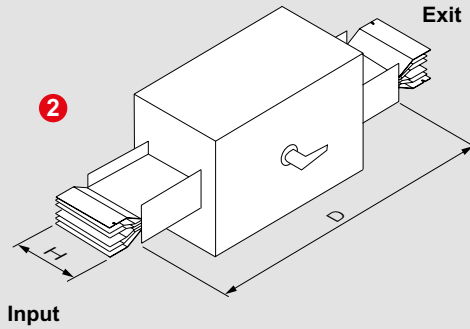
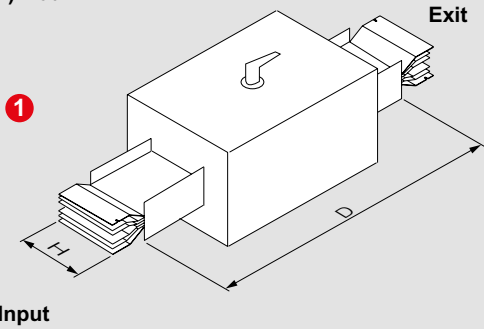

Dimension H changes with the rating; it is specified in the technical informations

### Section Isolator

The section isolator allows to protect and disconnect one part of the installation from the rest of the run

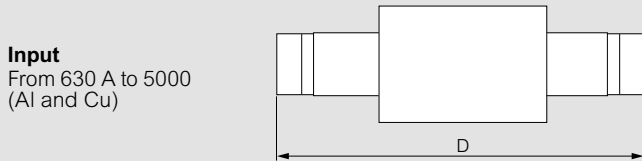

**Input**  
From 630 A to 5000 A  
(Al and Cu)

**Exit**  
From 630 A to 1250 A  
From 1600 A to 5000 A  
(Al and Cu)

EXIT	D
From 630 A to 1250 A	1500
From 1600 A to 5000 A	2000

### Rate Reducer with Isolator Switch

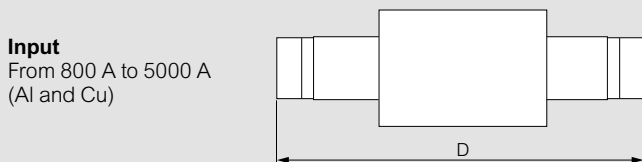

**Input**  
From 800 A to 5000 A  
(Al and Cu)

**Exit**  
From 630 A to 1250 A  
From 1600 A to 2500 A  
(Al and Cu)

EXIT	D
From 630 A to 1250 A	1500
From 1600 A to 2500 A	2000

Fuses not included. See general Legrand catalogue

Please contact Legrand for more details on the dimensions

# Super compact (SCP)

## tap-off boxes – Plug-in type

Plug-in boxes can be fitted on any element with tap-off outlets of the SCP busbar trunking system, irrespective of rating and conductor material

As normally expected, the PE protection conductor (or PEN if required), is the first to enter in contact with the distribution element during connection, and the one to disconnect the last during disconnection

Thanks to this feature, the boxes can be fitted and removed without disconnecting the power from the busbar

The cover can only be opened when the box is correctly installed and with the protection switch in the off position, thus ensuring the absence of the load

Moreover, an IP20 protection degree is guaranteed on all parts under voltage during all assembly and disassembly operations

These boxes can be accessorised with thermal magnetic circuit breakers, fuse carriers and switch disconnectors (AC23)

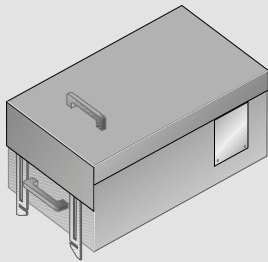

**Type 1 (from 63 A to 160 A)**

TYPE 1	Versions
Box Rating	
63 A	Empty
	With fuse carriers
125 A	With switch
	disconnector (AC23)
160 A	

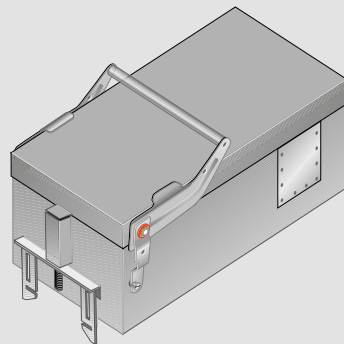

**Type 2 (from 250 A to 630 A)**

TYPE 2	Versions
Box Rating	
250 A	Empty
	With fuse carriers
400 A	With switch
	disconnector (AC23)
630 A	

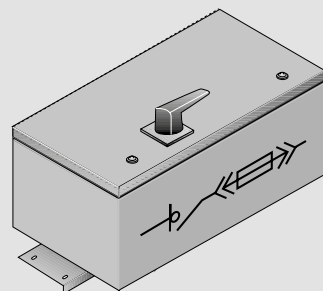

**Type 3 (from 125 A to 400 A)**

TYPE 3	Versions
Box Rating	
125 A	With (AC 23A)
	switch disconnector
250 A	and fuse carrier
400 A	

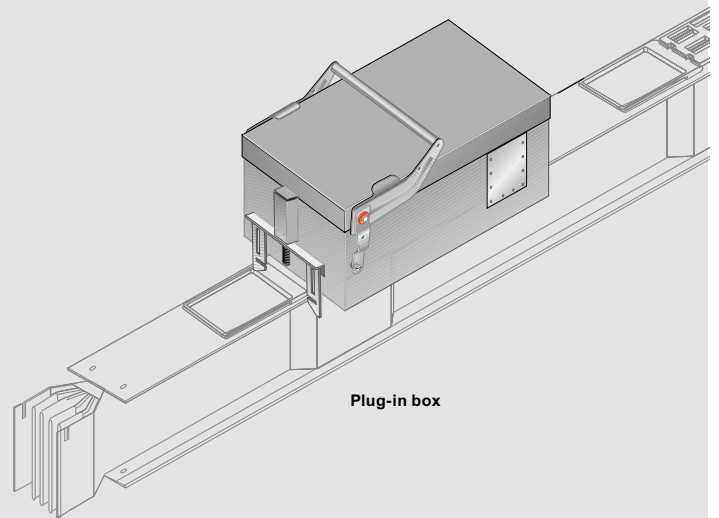

**Plug-in box**

## Super compact (SCP)

tap-off box Type 1 - 63 A to 160 A : plug-in type

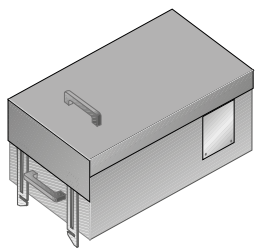

Type 1 (from 63A to 160A)

Pack	Cat.Nos	Empty Tap-off boxes
		Tap-off boxes can be pre-equipped with DPX moulded case circuit breakers (MCCB*) upon request Can be installed and removed when the busbar is energized To be applied on elements with any rating, with tap-off outlets
1	65285011P	In (A) tap-off box 63
1	65285012P	125
1	65285013P	160

Pack	Cat.Nos	Tap-off boxes with fuse carriers
		Polyester coated, galvanized steel structure. Metal boxes are suitable for heavy loads and are used to shield electromagnetic fields caused by flows of current Fuses not included
1	65285031P	In (A) tap-off box 63 Fuse carrier CH 22
1	65285032P	125 NH 00
1	65285033P	160 NH 00

Pack	Cat.Nos	Tap-off boxes with switch disconnecter (AC23)
		Polyester coated, galvanized steel structure. Metal boxes are suitable for heavy loads and are used to shield electromagnetic fields caused by flows of current These tap-off boxes are equipped with a switch disconnecter (AC23) and a fuse carrier. The disconnecter switch is operated through a rotary handle on the cover (not shown in the picture). N.B. Cover with AC21A disconnection: it is not possible to open, close, install or pull out the tap-off box if the switch is in "ON" position. Fuses not included. See Legrand catalogue Can be installed and removed when the busbar is energized To be applied on elements with any rating, with tap-off outlets
1	65285051P	In (A) tap-off box 63 Fuse carrier NH 000
1	65285052P	125 NH 00
1	65285053P	160 NH 0

\* MCCB ( Moulded Case Circuit Breaker )

## Super compact (SCP)

tap-off box Type 1 - 63 A to 160 A : plug-in type

### ■ Dimensions

#### Type 1 (from 63A to 160A)

Cover with AC21A disconnection

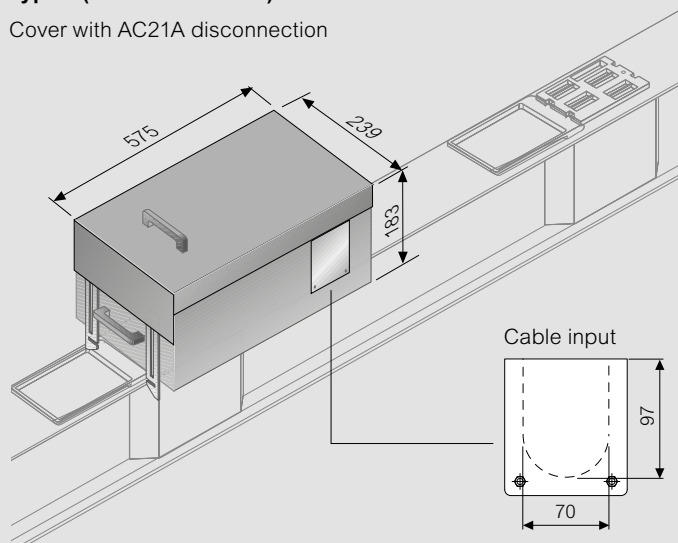

#### Box dimensions (mm)

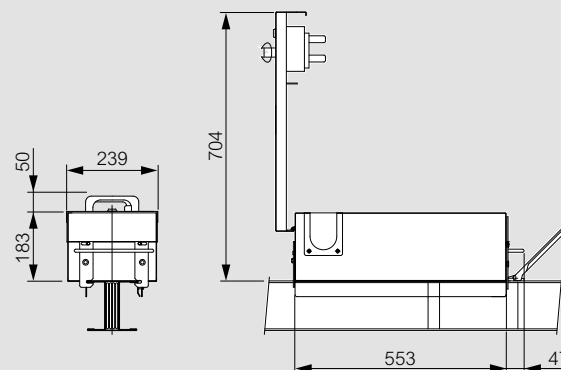

#### Terminal dimensions (mm)

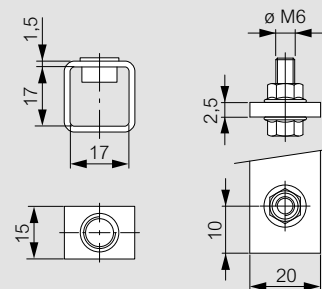

The terminals are refers to empty version (from 63A to 160A)

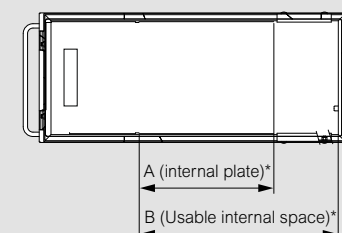

INTERNAL DIMENSIONS			
Type	In (A)	A (mm)	B (mm)
1	63	250	365
	125		
	160		

(\*) Refers to empty version

## Super compact (SCP)

tap-off box Type 2 - 250 A to 630 A: plug-in type

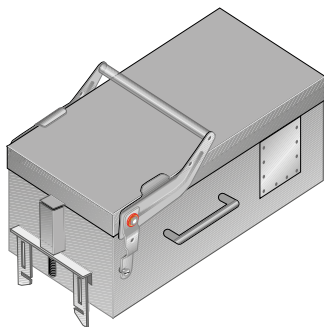

Type 2 (from 250A to 630A)

Pack	Cat.Nos	Empty Tap-off boxes
		Tap-off boxes can be pre-equipped with DPX moulded case circuit breakers (MCCB*) upon request Can be installed and removed when the busbar is energized To be applied on elements with any rating, with tap-off outlets
1	65285014P	In (A) tap-off box   250
1	65285016P	630

Tap-off boxes with fuse carriers		
		Polyester coated, galvanized steel structure Metal boxes are suitable for heavy loads and are used to shield electromagnetic fields caused by flows of current Fuses not included
1	65285034P	In (A) tap-off box   Fuse carrier   250   NH 2
1	65285036P	630   NH 3

Tap-off boxes with switch disconnecter (AC23)		
		Polyester coated, galvanized steel structure Metal boxes are suitable for heavy loads and are used to shield electromagnetic fields caused by flows of current These tap-off boxes are equipped with a switch disconnecter (AC23) and a fuse carrier. The disconnecter switch is operated through a rotary handle on the cover (not shown in the picture) N.B. Cover with AC21A disconnection: it is not possible to open, close, install or pull out the tap-off box if the switch is in "ON" position Can be installed and removed when the busbar is energized To be applied on elements with any rating, with tap-off outlets
1	65285054P	In (A) tap-off box   Fuse carrier   250   NH 1
1	65285055P	400   NH 2
1	65285076P	630   NH 3

\* MCCB ( Moulded Case Circuit Breaker )

**Single bar:**  
630A-2000A (Al)  
800A-2500A (Cu)

**Double bar:**  
2500A-4000A (Al)  
3200A-5000A (Cu)

## Super compact (SCP)

tap-off box Type 2 - 250 A to 630 A: plug-in type

### ■ Dimensions

#### Type 2 (from 250 A to 630 A)

Cover with AC21A disconnection

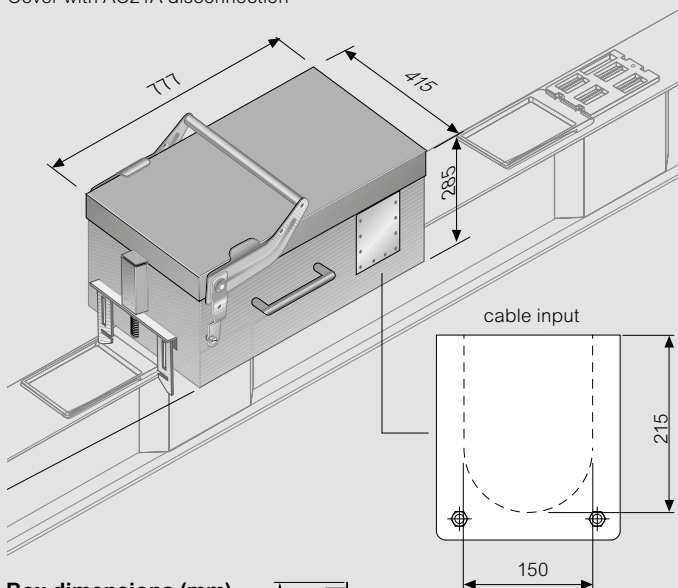

#### Box dimensions (mm)

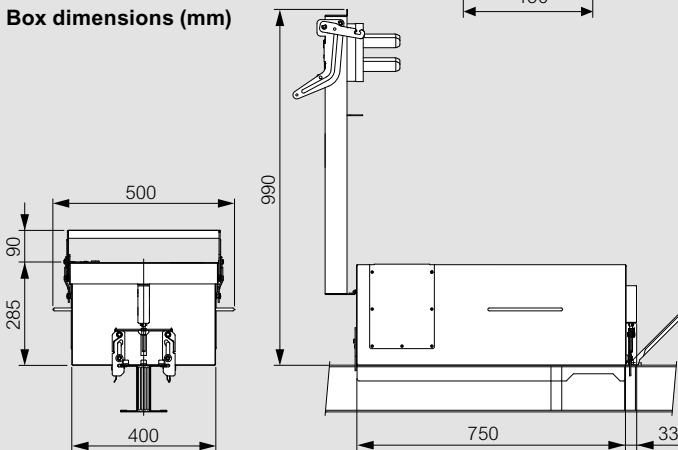

#### Terminal dimensions (mm)

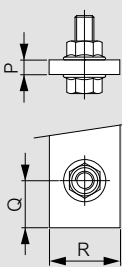

Type	In (A)	Phase/Neutral			Earth				
		P	Q	R	Thread	P	Q	R	Thread
2	250	2.5	17.5	35	M8	10.6	20	30	M10
	630	6	17.5	35	M8	10.6	20	30	M10

The terminals are refers to empty version (from 250A to 630A)

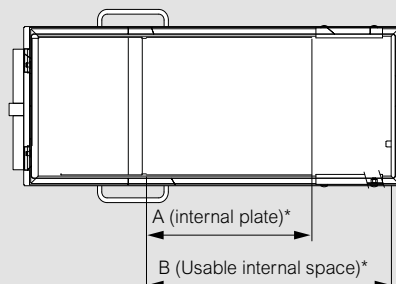

INTERNAL DIMENSIONS			
Type	In (A)	A (mm)	B (mm)
2	250	375	552
	400		
	630		

(\*) Refers to empty version

**Super compact (SCP) tap-off box with (AC 23 A) switch disconnector and fuse carrier, Type 3 - 125 A to 400 A: plug-in type**

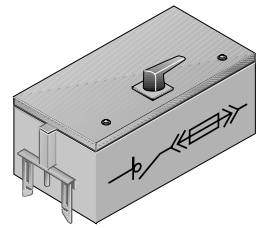

**Type 3 - from 125 A to 400 A**

Rated insulating AC voltage  $U_i$  [V]: **1000**  
 Rated impulse withstand voltage  $U_{imp}$  [kV]: **12**  
 Type of rated duty: **AC23A**  
 Rated conditional short circuit current [kA]: **100**  
 Reference standard: **CEI EN 60947-3**

Pack	Cat.Nos	Tap-off box with ac23a switch disconnector and fuse carrier, 125A to 400A: plug-in type	
		In (A) tap-off box	Fuse carrier
1	65282001P	125	NH 00
1	65282002P	250	NH 1
1	65282003P	400	NH 2

**Super compact (SCP) tap-off box with (AC 23 A) switch disconnector and fuse carrier, Type 3 - 125 A to 400 A: plug-in type**

**Dimensions**

**Type 3 - from 125 A to 400 A**

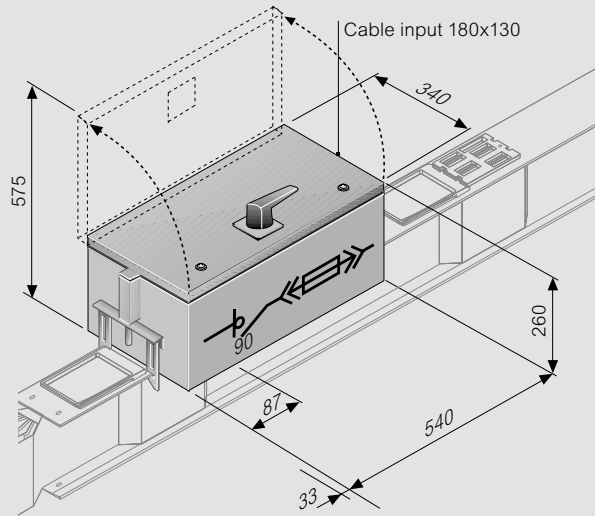

Can be installed and removed when the busbar is energized. To be applied on elements with any rating, with tap-off outlets

For operating voltages ( $U_e$ ) different from 400V, please contact Legrand

Fuses not included. See general Legrand catalogue

**Box dimensions (mm)**

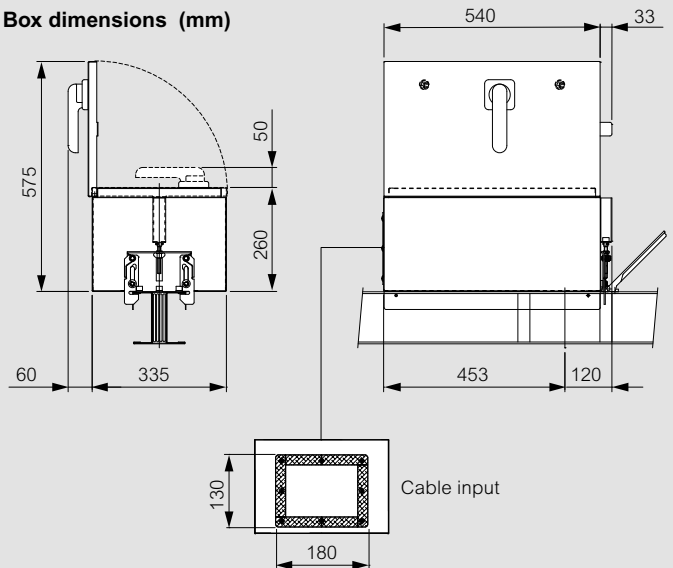

**Terminal dimensions (mm)**

Type	In (A)	Phase/Neutral				Earth			
		P	Q	R	Thread	P	Q	R	Thread
3	125	4	8	16	M8	2.5	20	20	M8
	250	4	12	25	M10	2.5	20	20	M8
	400	6	12	25	M10	2.5	20	20	M8

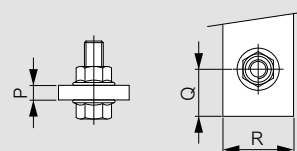

# Super compact (SCP)

## tap-off boxes on the junction – Bolt-on type

### Technical informations

Tap-off boxes on the junction – bolt-on type are high rated current boxes, securely connected to the busbar using a special "Monobloc" system similar to that used for straight elements, but which enables the distribution of power from the busbar

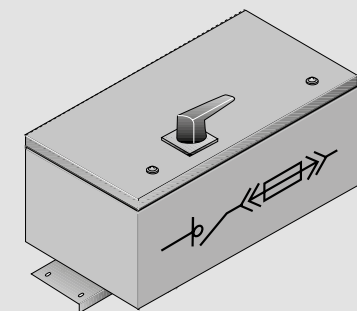

Type 4 (from 125 A to 1250 A)

TYPE 4	Versions:
Box Rating	
125A	
250A	
400A	With (AC 23A)
630A	switch disconnecter
800A	and fuse carrier
1000A	
1250A	

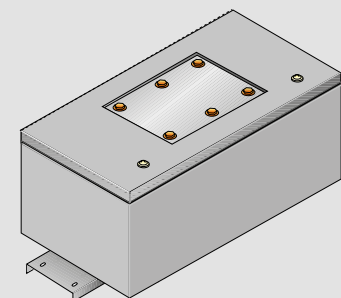

Type 5 (from 125 A to 1250 A)

TYPE 5	Versions:
Box Rating	
125A	
250A	
400A	
630A	Empty
800A	
1000A	
1250A	

The boxes can only be installed and removed with when no voltage is present in the busbar (disconnected)  
 These boxes are available in the version with switch disconnecter, fuse carrier, and boxed automatic circuit breakers

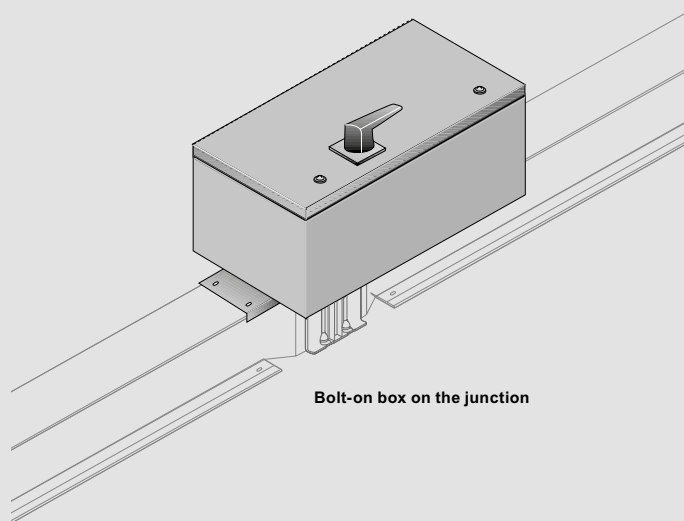

Bolt-on box on the junction

# Super compact (SCP)

tap-off box on the junction - Type 4 - 125 A to 1250 A: bolt-on type

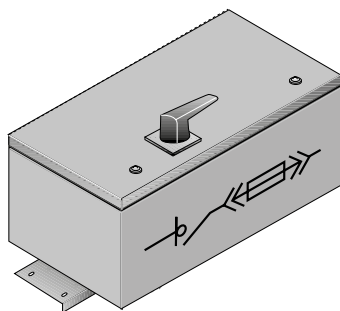

## Type 4 - from 125 A to 400 A

Rated insulating AC voltage  $U_i$  [V]: **1000**  
 Rated impulse withstand voltage  $U_{imp}$  [kV]: **12**  
 Type of rated duty: **AC23A**  
 Rated conditional short circuit current [kA]: **100**  
 Reference standard: **CEI EN 60947-3**

Pack	Cat.Nos		With AC23 switch disconnecter and fuse carrier				Pack	Cat.Nos		With AC23 switch disconnecter and fuse carrier (continued)			
	Al	Cu	In (A) bars	In (A) tap-off box	Fuse carrier	Type		Al	Cu	In (A) bars	In (A) tap-off box	Fuse carrier	Type
1	65281811P	-	630	125	NH 00	<b>4A</b>	1	65281851P	-	630	800	NH 4	<b>4C</b>
1	65281811P	65281811P	800				1	65281851P	65281851P	800			
1	65281811P	65281811P	1000				1	65281851P	65281851P	1000			
1	65281811P	65281811P	1250				1	65281851P	65281851P	1250			
1	65281812P	65281812P	1600				1	65281852P	65281852P	1600			
1	65281814P	65281812P	2000				1	65281854P	65281852P	2000			
1	65391812P	65281814P	2500				1	65391852P	65281854P	2500			
1	65391813P	65391812P	3200				1	65391853P	65391852P	3200			
1	65391814P	65391813P	4000				1	65391854P	65391853P	4000			
1	-	65391814P	5000				1	-	65391854P	5000			
1	65281821P	-	630	250	NH 1	<b>4A</b>	1	65281861P	-	630	1000	NH 4	<b>4C</b>
1	65281821P	65281821P	800				1	65281861P	65281861P	800			
1	65281821P	65281821P	1000				1	65281861P	65281861P	1000			
1	65281821P	65281821P	1250				1	65281861P	65281861P	1250			
1	65281822P	65281822P	1600				1	65281862P	65281862P	1600			
1	65281824P	65281822P	2000				1	65281864P	65281862P	2000			
1	65391822P	65281824P	2500				1	65391862P	65281864P	2500			
1	65391823P	65391822P	3200				1	65391863P	65391862P	3200			
1	65391824P	65391823P	4000				1	65391864P	65391863P	4000			
1	-	65391824P	5000				1	-	65391864P	5000			
1	65281831P	-	630	400	NH 2	<b>4A</b>	1	65281871P	-	630	1250	NH 4	<b>4C</b>
1	65281831P	65281831P	800				1	65281871P	65281871P	800			
1	65281831P	65281831P	1000				1	65281871P	65281871P	1000			
1	65281831P	65281831P	1250				1	65281871P	65281871P	1250			
1	65281832P	65281832P	1600				1	65281872P	65281872P	1600			
1	65281834P	65281832P	2000				1	65281874P	65281872P	2000			
1	65391832P	65281834P	2500				1	65391872P	65281874P	2500			
1	65391833P	65391832P	3200				1	65391873P	65391872P	3200			
1	65391834P	65391833P	4000				1	65391874P	65391873P	4000			
1	-	65391834P	5000				1	-	65391874P	5000			
1	65286041P	-	630	630	NH 3	<b>4B</b>	1	65286041P	-	630			
1	65286041P	65286041P	800				1	65286041P	65286041P	800			
1	65286041P	65286041P	1000				1	65286041P	65286041P	1000			
1	65286041P	65286041P	1250				1	65286041P	65286041P	1250			
1	65286042P	65286042P	1600				1	65286042P	65286042P	1600			
1	65286044P	65286042P	2000				1	65286044P	65286042P	2000			
1	65396042P	65286044P	2500				1	65396042P	65286044P	2500			
1	65396043P	65396042P	3200				1	65396043P	65396042P	3200			
1	65396044P	65396043P	4000				1	65396044P	65396043P	4000			
1	-	65396044P	5000				1	-	65396044P	5000			



**Single bar:**  
 630A-2000A (Al)  
 800A-2500A (Cu)

**Double bar:**  
 2500A-4000A (Al)  
 3200A-5000A (Cu)

# Super compact (SCP)

tap-off box on the junction - Type 4 - 125 A to 1250 A: bolt-on type

## Dimensions

Type 4 - from 125 A to 1250 A  
Box dimensions (mm)

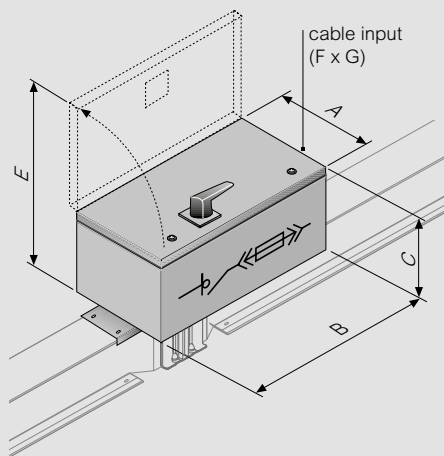

Type	In (A)	A	B	C	D	E	F	G	H	I	L	M
4A	125											
	250	365	630	270	115	630	290	180	287	59	520	50
	400											
4B	630	400	750	280	115	675	290	180	297	74	640	64
	800											
4C	1000	450	1050	300	115	745	380	210	317	74	940	64
	1250											

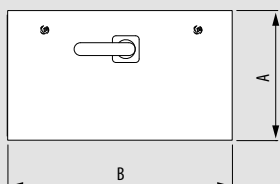
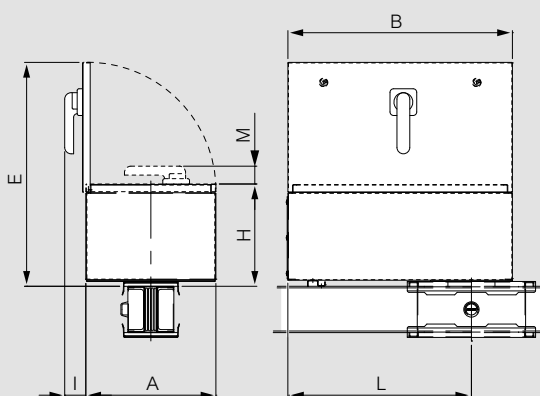
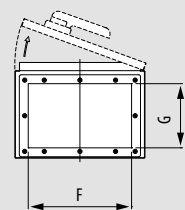
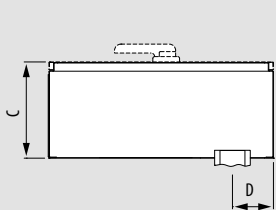

## Terminal dimensions (mm)

Type	In (A)	Phase/Neutral				Earth							
		P	Q	R	Thread	P	Q	R	Thread				
4A	125	4	8	16	M8	3.3	20	30	M8				
	250	4	12	25	M10	3.3	20	30	M8				
	400	6	12	25	M10	3.3	20	30	M8				
4B	630	10	19	40	M10	5.3	20	30	M8				
4C													
	800	4	25	45	M16	12.4	20	30	M10	6.2	20	30	M8
	1000	4	25	45	M16	12.4	20	30	M10	6.2	20	30	M8
	1250	4	25	45	M16	10	25	45	M12	6.2	20	30	M8

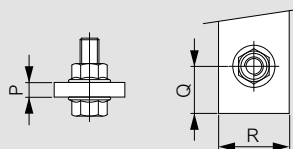

In order to finalize the order, it is necessary to specify the type of Super Compact SCP the box will be installed on

The boxes cannot be installed simultaneously on both sides of the same junction

### WARNING

The bolted boxes are to be installed directly on the junction when the busbar is disconnected and not energized. For operating voltages (Ue) different from 400V please contact Legrand

Fuses not included. See general Legrand catalogue

## Super compact (SCP)

tap-off box on the junction - Type 5 - 125 A to 1250 A: bolt-on type

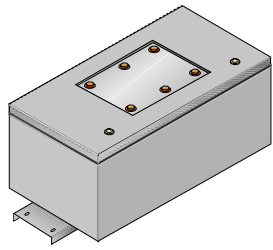

Type 5 - from 125 A to 1250 A

Pack	Cat.Nos	Empty tap-off box 125 A to 1250 A: bolt-on type	
		Type	In (A) tap-off box
-	on-demand manufacturing	<b>5A</b>	125 A
-			250 A
-			400 A
-	on-demand manufacturing	<b>5B</b>	630 A
-	on-demand manufacturing	<b>5C</b>	800 A
-			1000 A
-			1250 A

## Super compact (SCP)

tap-off box on the junction - Type 5 - 125 A to 1250 A: bolt-on type

### ■ Dimensions

#### Type 5 - from 125 A to 1250 A

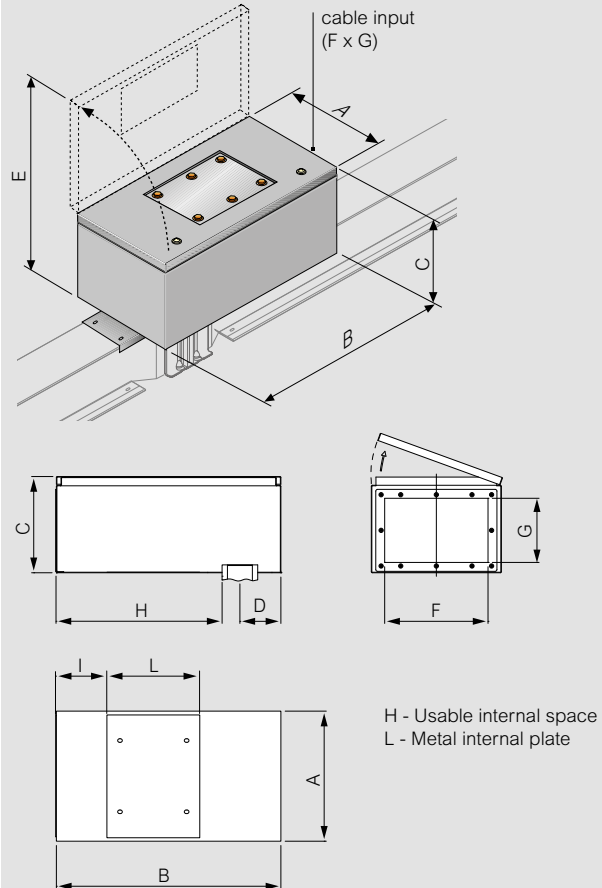

Type	In (A)	A	B	C	D	E	F	G	H	I	L
<b>5A</b>	125										
	250	365	630	270	115	630	290	180	465	142	260
	400										
<b>5B</b>	630	400	750	280	115	675	290	180	585	227	295
	800										
<b>5C</b>	1000	450	1050	300	115	745	380	210	885	254	545
	1250										

### Terminal dimensions (mm)

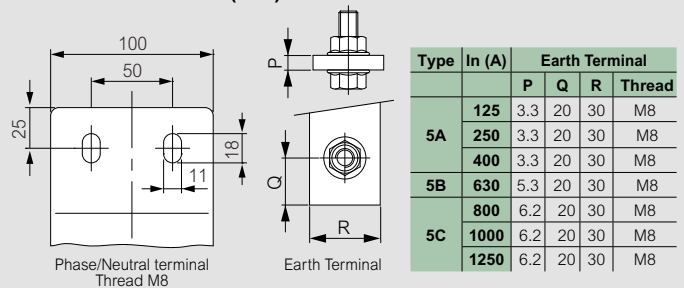

Type	In (A)	Earth Terminal			
		P	Q	R	Thread
<b>5A</b>	125	3.3	20	30	M8
	250	3.3	20	30	M8
	400	3.3	20	30	M8
<b>5B</b>	630	5.3	20	30	M8
	800	6.2	20	30	M8
<b>5C</b>	1000	6.2	20	30	M8
	1250	6.2	20	30	M8

### ⚠ WARNING

The bolted boxes are to be installed when the busbar is disconnected and not energized

In order to finalize the order, it is necessary to specify the type of Super Compact SCP the box will be installed on

Tap-off boxes can be pre-equipped with DPX moulded case circuit breakers (MCCB) upon request

Please contact Legrand for more details on the dimensions

**Single bar:**  
630A-2000A (Al)  
800A-2500A (Cu)

**Double bar:**  
2500A-4000A (Al)  
3200A-5000A (Cu)

# Tap-off box installation example diagram

## example diagram

### Technical informations

Not all boxes can be installed in any position

The following figures show where the various Plug-in/Bolt-on boxes may be installed on elements with standard setup

The numbers indicate the type of box:

- 1 Plug-in type : tap-off box from 63A to 160A;
- 2 Plug-in type : tap-off box from 250A to 630A;
- 3 Plug-in type : tap-off box from 125A to 400A with (AC 23A) switch disconnecter and fuse carrier;
- 4 Bolt-on type: tap-off box on the junction from 125A to 1250A with (AC 23A) switch disconnecter and fuse carrier;
- 5 Bolt-on type: tap-off box on the junction from 125A to 1250A empty version;

### Different combination of boxes in straight elements of SCP:

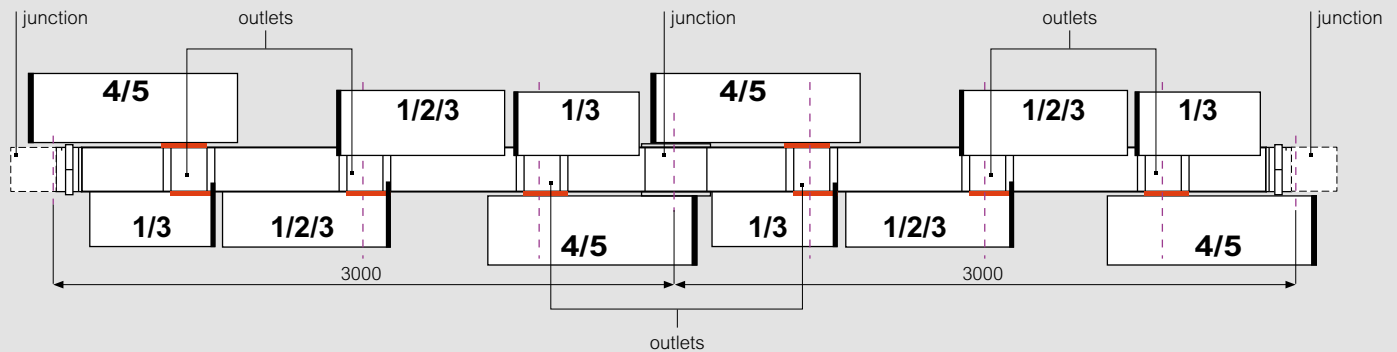
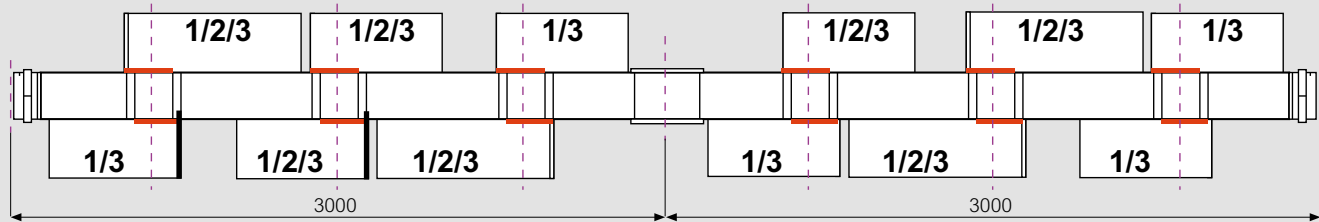
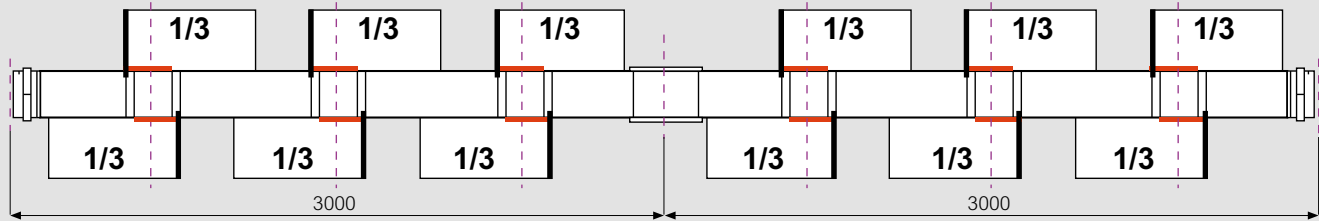

# Super compact (SCP)

## brackets

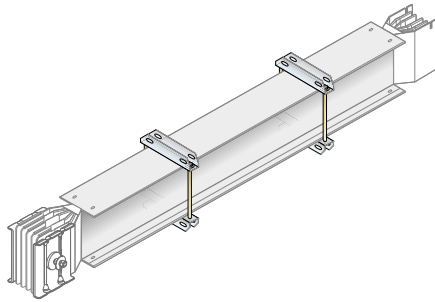

65202001

The brackets enable sturdy installation of the busbar to the system support structures  
 The recommended installation distance between brackets is 1.5 metres  
 Legrand offers suitable bracket solutions certified for any type of installation, even in the most difficult environments:

- installations subjected to strong vibrations;
- naval applications;
- installation in seismic environments

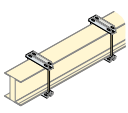
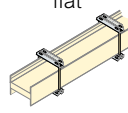
Pack	Cat.Nos		In (A)	Type
	Al	Cu		
1	65202001	-	630	edgewise 
1	65202001	65202001	800-1250	
1	65202002	65202002	1600	
1	65202004	65202002	2000	
1	65222002	65202004	2500	
1	65222003	65222002	3200	
1	65222004	65222003	4000	
1	-	65222004	5000	
1	65202001	-	630	flat 
1	65202001	65202001	800-250	
1	65202013	65202013	1600-2000	
1	65202112	65202013	2500	
1	65202113	65202112	3200	
1	65202114	65202113	4000	
1	-	65202114	5000	

# Super compact (SCP)

## brackets

### ■ Dimensions

#### Suspension bracket

##### Edgewise installation

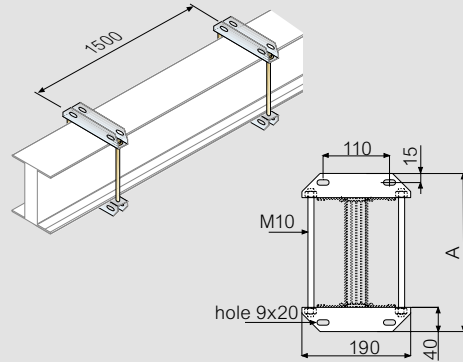

Range	A (mm)	
	Al	Cu
630	210	-
800	210	210
1000	210	210
1250	210	210
1600	250	250
2000	300	250
2500	460	300
3200	520	460
4000	560	520
5000	-	560

##### Flat installation

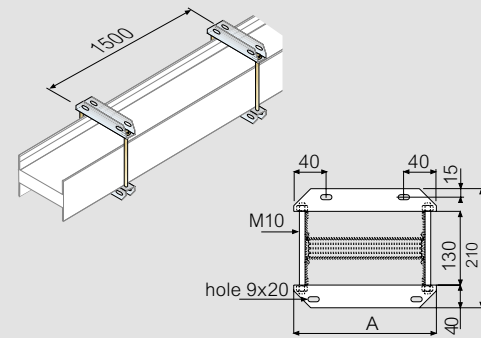

Range	A (mm)	
	Al	Cu
630	190	-
800	190	190
1000	190	190
1250	190	190
1600	315	315
2000	315	315
2500	430	315
3200	490	430
4000	530	490
5000	-	530

# Super compact (SCP)

## brackets

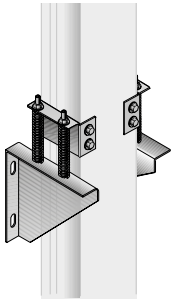

65213711

Pack	Cat.Nos		In (A)	Type	
	Al	Cu			
1	65213711	-	630	With bracket and springs	<b>A</b>
1	65213711	65213711	800-1250		
1	65213712	65213712	1600		
1	65213714	65213714	2000		
1	65213742	65213714	2500		
1	65213743	65213742	3200		
1	65213744	65213743	4000		
1	-	65213744	5000		
1	65213721	-	630	With bracket	<b>B</b>
1	65213721	65213721	800-1250		
1	65213722	65213722	1600		
1	65213724	65213722	2000		
1	65213752	65213724	2500		
1	65213753	65213752	3200		
1	65213754	65213753	4000		
1	-	65213754	5000		
1	65213701	-	630	With springs	<b>C</b>
1	65213701	65213701	800-1250		
1	65213702	65213702	1600		
1	65213704	65213702	2000		
1	65213732	65213704	2500		
1	65213733	65213732	3200		
1	65213734	65213733	4000		
1	-	65213734	5000		
1	65213761	-	630	Bracket only	<b>D</b>
1	65213761	65213761	800-1250		
1	65213762	65213762	1600		
1	65213764	65213762	2000		
1	65213772	65213764	2500		
1	65213773	65213772	3200		
1	65213774	65213773	4000		
1	-	65213774	5000		
1	-	-	630-2000	Naval applications	<b>E</b>
1	65213782	-	2500		
1	65213783	65213782	3200		
1	65213784	65213783	4000		
1	-	65213784	5000		
1	-	-	630-2000	* Anti-seismic bracket	<b>B</b>
1	65213792	-	2500		
1	65213793	65213792	3200		
1	65213794	65213793	4000		
1	-	65213794	5000		

\*For more technical details, please contact Legrand



**Single bar:**

630A-2000A (Al)  
800A-2500A (Cu)

**Double bar:**

2500A-4000A (Al)  
3200A-5000A (Cu)

# Super compact (SCP)

## brackets

### Dimensions

#### Type 1

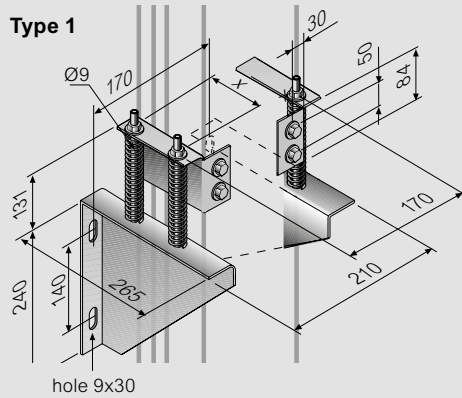

#### Type 2

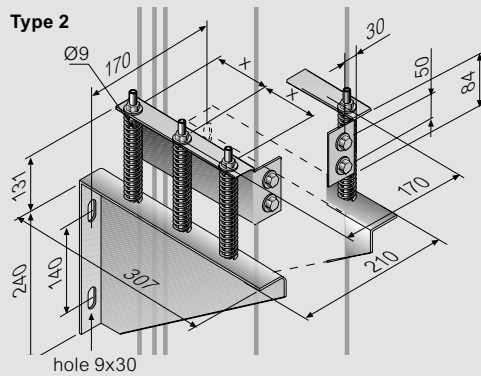

#### Type 3

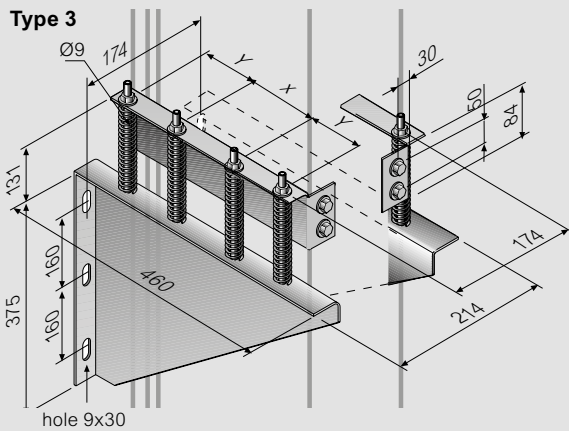

#### Type 4

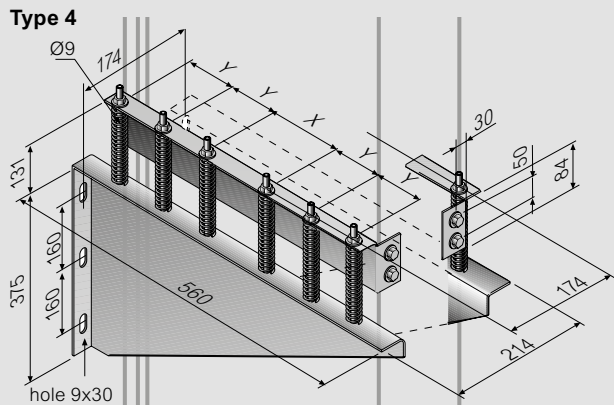

### X AND Y DIMENSIONS OF THE BRACKETS

	Type 1	Type 1	Type 2	Type 3	Type 4	Type 4
<b>Al</b>	630A - 1250A	1600A	2000A	2500A	3200A	4000A
<b>Cu</b>	800A - 1250A	1600A - 2000A	2500A	3200A	4000A	5000A
<b>x [mm]</b>	90	120	90	110	80	80
<b>y [mm]</b>	-	-	-	115	80	90

# Fixing indication

## brackets

### Technical informations

For vertical path **sections of less than 2 m** the use of standard suspension brackets is sufficient

#### 1- Horizontal installation fixing

Fixing recommended: 1 bracket every 1.5 metres

#### 2- Fixing for vertical installation (rising mains)

In case of rising mains, in addition to the standard brackets it will also be necessary to use other screw fixed brackets to prevent sliding of the busbar. Thanks to pre-loaded springs, these brackets absorb the forces pressing on the busbar and direct any expansion in a precise direction. They therefore operate as a limitation, and support the traction and compression forces of the busbar trunking system

##### • Section line between 2 and 4 m

In the lowest point **Type B** vertical bracket if secured **to the wall**, or **Type D** if secured **to the floor** + one edgewise installation **standard bracket**

##### • Section line of over 4 m

In the lowest point **Type A** vertical bracket if secured **to the wall**, or **Type C** if secured **to the floor** + one edgewise installation **standard bracket** every metre and a half of the path + **one Type A or C** bracket based on the following table

Al		Cu	
In (A)	m	In (A)	m
630	17		
800	16	800	10
1000	16	1000	9
1250	15	1250	9
1600	12	1600	7
2000	10	2000	6
2500	14	2500	4
3200	12	3200	7
4000	10	4000	6
		5000	5

#### 3- Fixing for installation in seismic environments in horizontal

Fit 1 bracket every metre and a half of the busbar  
Every 2 anti-seismic brackets with bracket (Type B), use one standard bracket

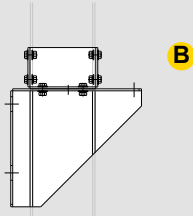

#### 4- Fixing for installation in seismic environments in vertical (section lengths > 2 m)

Fit 1 bracket every metre and a half of the busbar  
Every 2 anti-seismic brackets with bracket (Type B) use one bracket with bracket and spring (Type A)

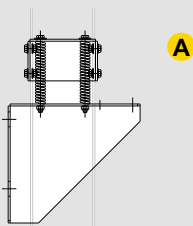

#### 5- Fixing for naval installation

For naval installations always use a type E bracket every metre and a half of the busbar

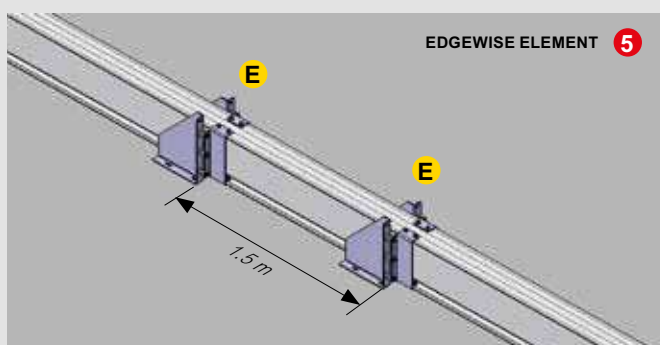
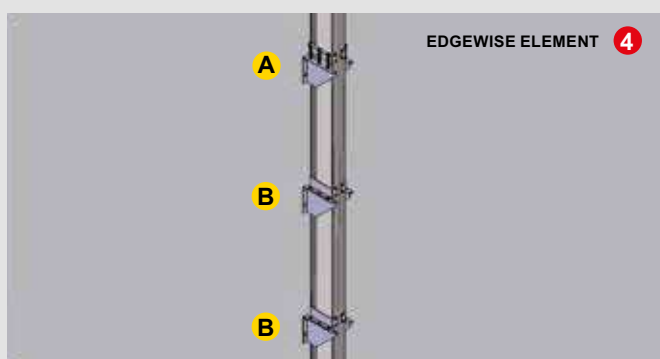
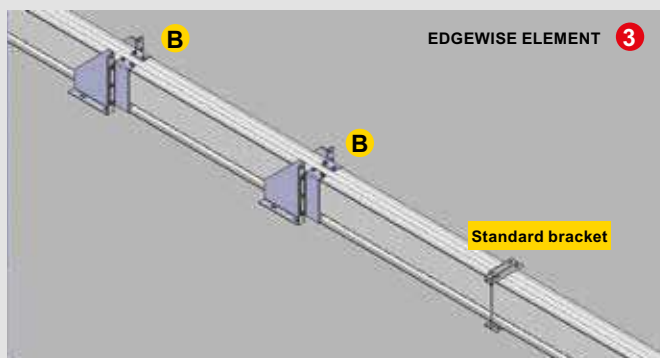
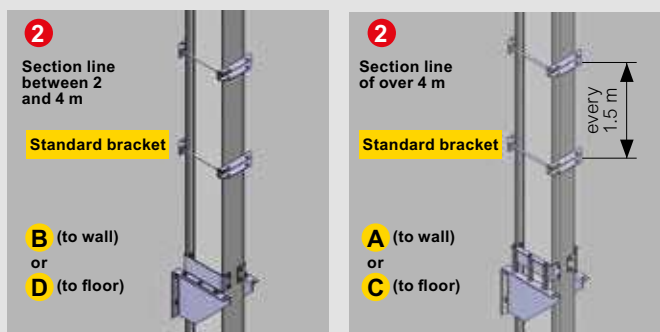
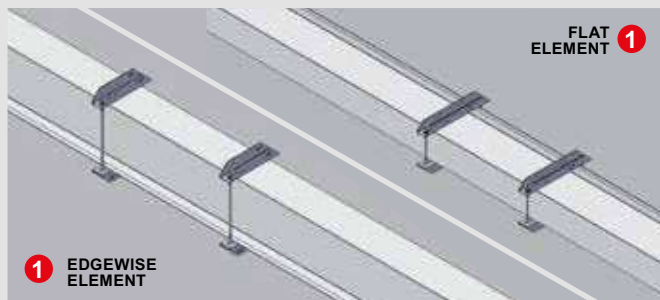
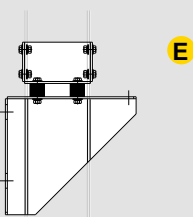

For more installation details, please refer to the installation instructions.

## Super compact (SCP)

### operating instructions on how to design riser mains

- 1) Use an RH end feed unit (without monobloc)  
In order to position the tap-off boxes correctly as shown in the figure, the neutral conductor of the riser main must be on the left side of the element
- 2) Use one or more suspension brackets for the vertical elements, according to the weight of the whole riser mains. For risers that are shorter than 4 meters, fix to the base with type B brackets (see pag.123) when longer, use a type A suspension brackets (see pag.123) every 300kg of riser (including the boxes);
- 3) Use a standard suspension bracket to hang the busbar every 2 metres of riser mains
- 4) Use elements with tap-off outlets where necessary, distribute the power using plug-in boxes
- 5) Use S120 fire barrier kit for each compartment floor, where specifically requested
- 6) The tap-off boxes can be installed in the tap-off outlets and near the connection between the elements
- 7) At the end of the riser mains, position the IP55 end cover

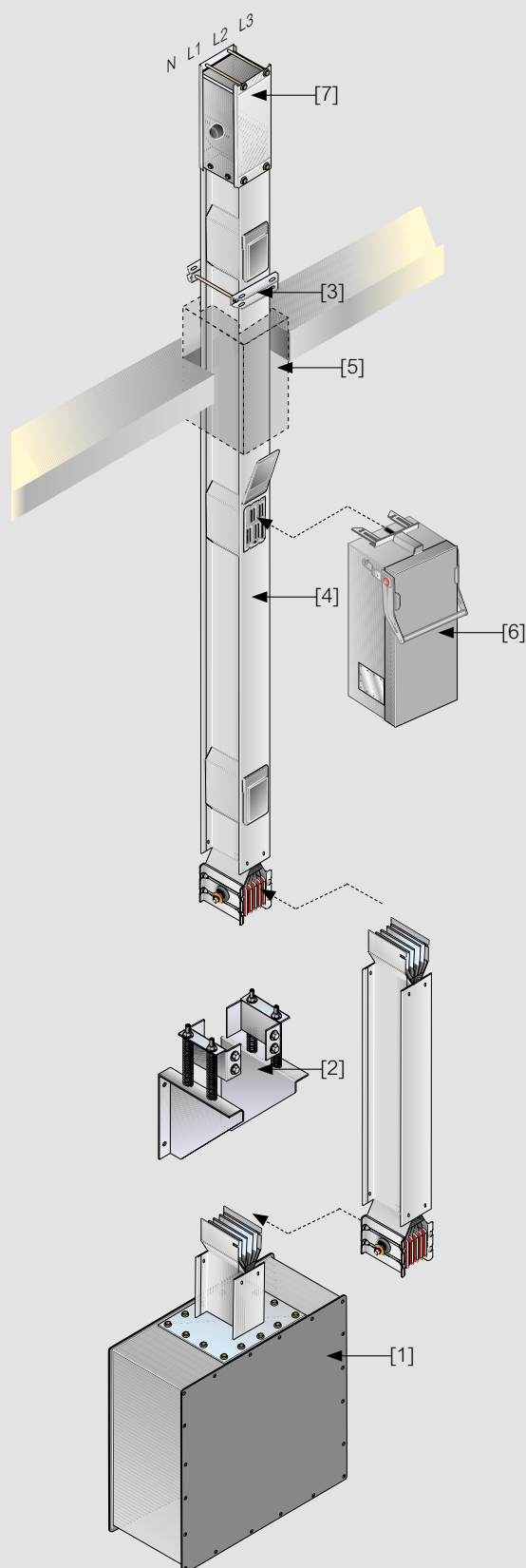

# Super compact (SCP)

accessories

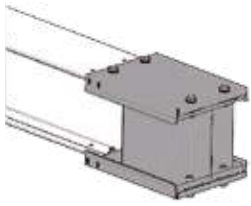

65283101P

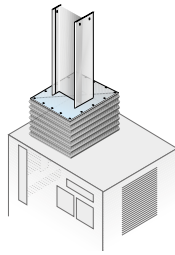

SF766040

Pack	Cat.Nos		End cover IP55
	Al	Cu	In (A)
1	65283101P	-	630
1	65283101P	65283101P	800
1	65283101P	65283101P	1000
1	65283101P	65283101P	1250
1	65283102P	65283102P	1600
1	65283104P	65283102P	2000
1	65393102P	65283104P	2500
1	65393103P	65393102P	3200
1	65393104P	65393103P	4000
1	-	65393104P	5000

The end cover is the component that ensures an IP55 protection degree at the end of the line

	Al	Cu	Protective bellow
			In (A)
1	SF766040	-	630
1	SF766040	SF766040	800 - 2000
1	SF927140	SF766040	2500
1	SF927140	SF927140	3200 - 4000
1	-	SF927140	5000

Recommended for protection of the interface connection on electric boards, dry-type transformer with enclosure and oil-type transformers

**Note:** for more details on Protective cover for outdoor applications, please contact Legrand

**Single bar:**  
630A-2000A (Al)  
800A-2500A (Cu)

**Double bar:**  
2500A-4000A (Al)  
3200A-5000A (Cu)

# Super compact (SCP)

accessories

## ■ Dimensions

### End cover IP55

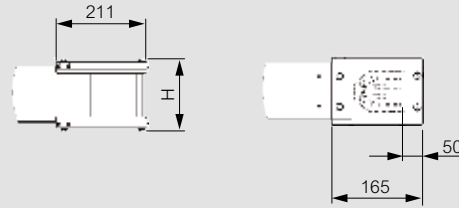

### Protective bellow

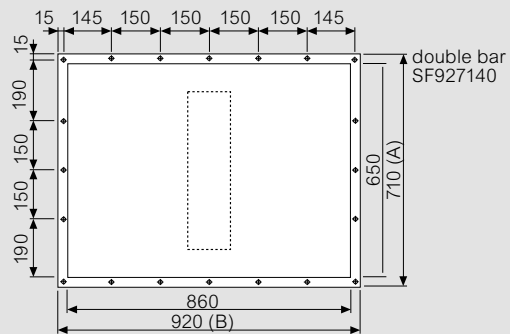
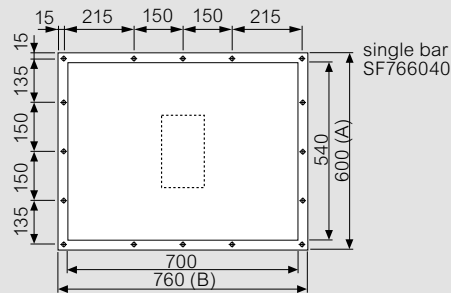
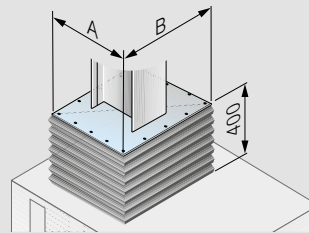

### Protective cover for outdoor applications

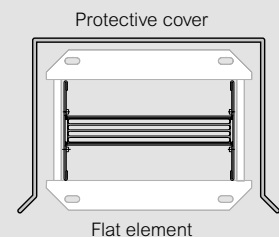
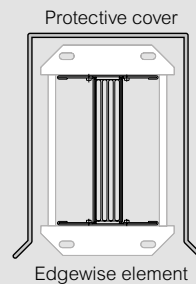

Covering accessory to be used for outdoor installations and wherever the standard IP55 Degree of protection is not adequate

The protective cover for outdoor applications does not change the degree of protection IP of the busbar duct

## Super compact (SCP)

### flexible braid connections



Flexible

Flexible braid connections are used to connect the transformer to the connection interface of the busbar when mechanically uncoupling the two elements is required, to prevent the transmission of vibrations

Pack	Cat.Nos		Flexible braid connections		
	Al	Cu	In (A)	N° braid per phase	L (mm)
1	FC100010	-	630	1	300-450
1	FC100010	FC100010	800		
1	FC200010	FC200010	1000		
1	FC300010	FC300010	1250		
1	FC500010	FC500010	1600		
1	FC600010	FC600010	2000		
1	FC400010	FC400010	2500	2	300-450
1	FC500010	FC500010	3200		
1	FC600010	FC600010	4000		
1	-	FC700010	5000		
1	FC100020	-	630	1	451-600
1	FC100020	FC100020	800		
1	FC200020	FC200020	1000		
1	FC300020	FC300020	1250		
1	FC500020	FC500020	1600		
1	FC600020	FC600020	2000		
1	FC400020	FC400020	2500	2	451-600
1	FC500020	FC500020	3200		
1	FC600020	FC600020	4000		
1	-	FC700020	5000		
1	FC100030	-	630	1	601-750
1	FC100030	FC100030	800		
1	FC200030	FC200030	1000		
1	FC300030	FC300030	1250		
1	FC500030	FC500030	1600		
1	FC600030	FC600030	2000		
1	FC400030	FC400030	2500	2	601-750
1	FC500030	FC500030	3200		
1	FC600030	FC600030	4000		
1	-	FC700030	5000		
1	FC100099	-	630	1	> 750
1	FC100099	FC100099	800		
1	FC200099	FC200099	1000		
1	FC300099	FC300099	1250		
1	FC500099	FC500099	1600		
1	FC600099	FC600099	2000		
1	FC400099	FC400099	2500	2	> 750
1	FC500099	FC500099	3200		
1	FC600099	FC600099	4000		
1	-	FC700099	5000		

**Note:** for insulated flexible braid, please contact Legrand.



**Single bar:**

630A-2000A (Al)  
800A-2500A (Cu)

**Double bar:**

2500A-4000A (Al)  
3200A-5000A (Cu)

## Super compact (SCP)

### flexible braid connections

#### Dimensions

##### Flexible

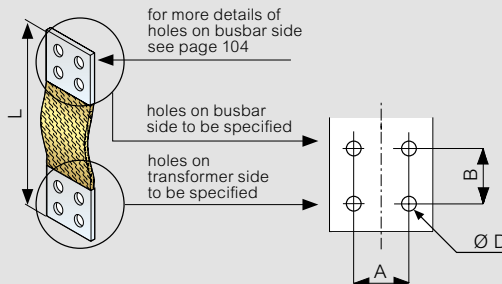

When ordering, specify:  
holes on transformer side/busbar side  
(dimensions A, B, Ø D) and length L

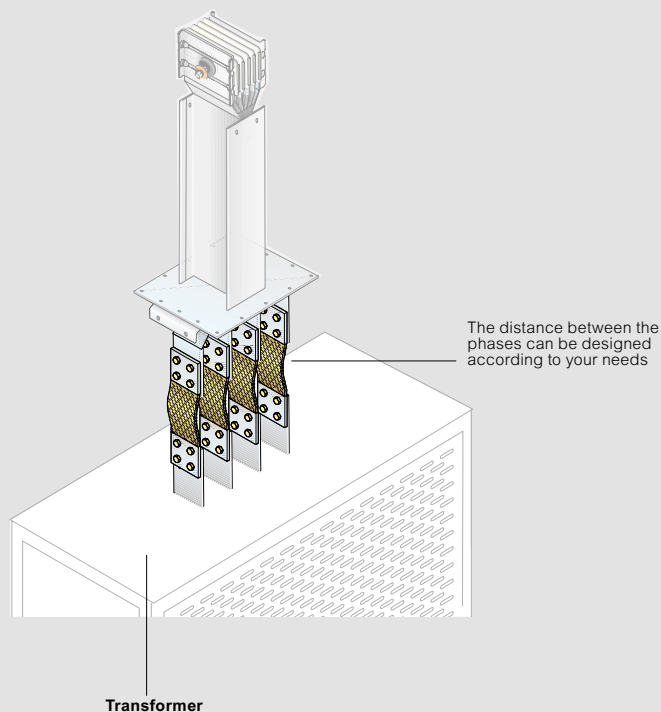

# Super compact (SCP)

## ATR elements

### ATR elements

ATR are elements used for connection to electric boards or transformers, similar in everything to straight elements. These elements may be used for connection to both cast resin and oil transformers, and offer the advantage that the connection interfaces may be installed directly on the vertical section of the transformer terminals, minimising the time required for the connection of the busbar trunking system to the transformer. Each element is designed based on precise connection specifications supplied by the customer.

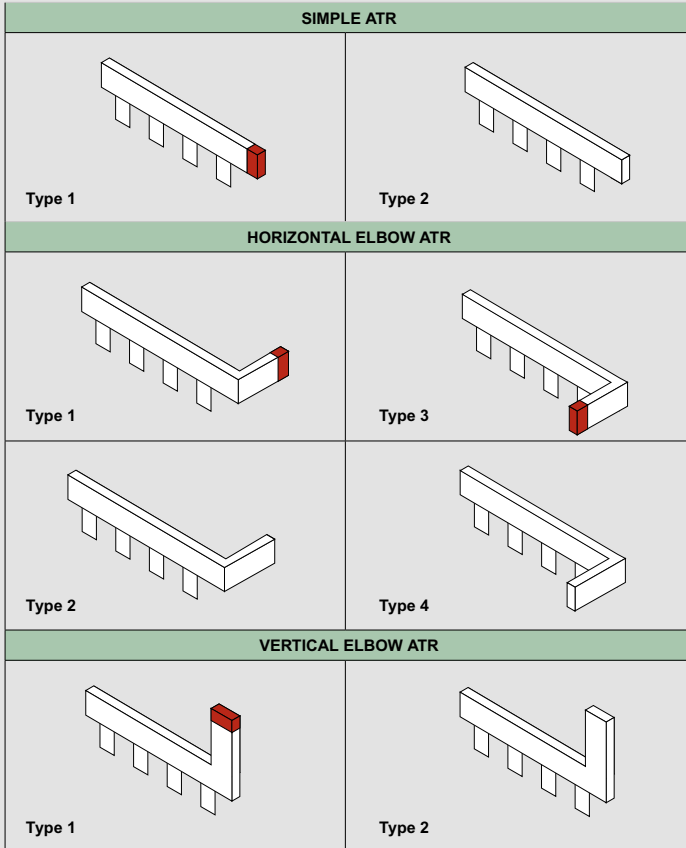

### Dimensions

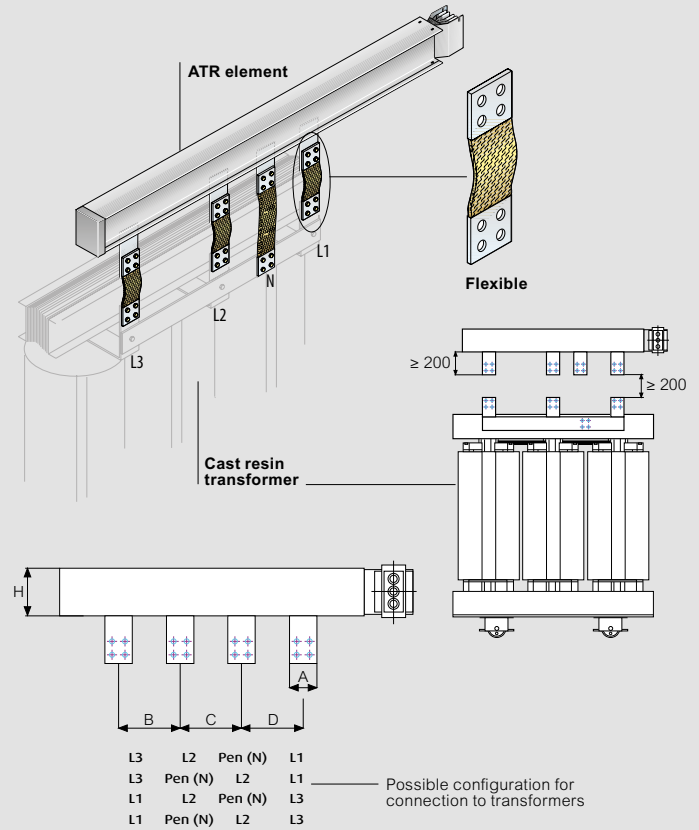

### ATR dimensions

Although designed ad-hoc, ATR elements are still subjected to construction limits. Below are the summarizing tables indicating these values

In (A)	INTERAXES (mm)									
	Al					Cu				
	A	B	C	D	H	A	B	C	D	H
630	75	165	165	165	130	-	-	-	-	-
800	110	165	165	165	130	75	165	165	165	130
1000	110	165	165	165	130	110	165	165	165	130
1250	120	165	165	165	130	110	165	165	165	130
1600	155	205	205	205	170	150	205	205	205	170
2000	205	255	255	255	220	160	205	205	205	170
2500	150	205	205	205	380	200	255	255	255	220
3200	180	235	235	235	440	150	205	205	205	380
4000	205	255	255	255	480	180	235	235	235	440
5000	-	-	-	-	-	200	255	255	255	480

■ The system: the Legrand transformer advantage

Type A setup

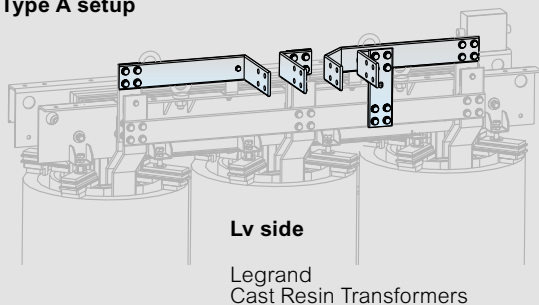

Type B setup

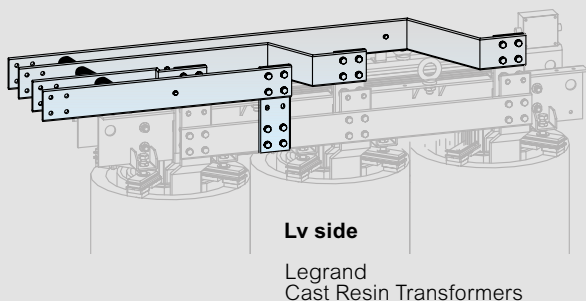

Type C setup

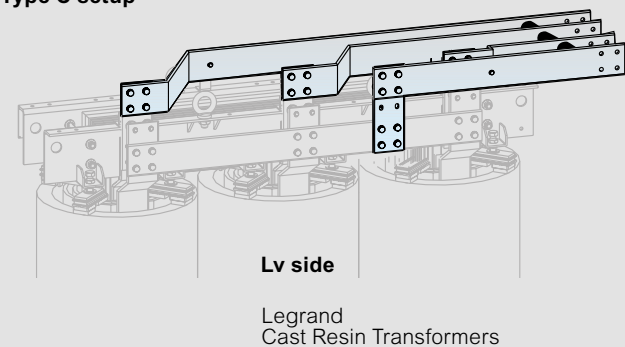

The Legrand group product synergy answers to the global installation need  
The Legrand cast resin transformers have specifically designed connections for the Legrand busbars

The versions shown represent some of the standardized solutions

Please contact Legrand for more details on the dimensions

■ The system: the Legrand XL<sup>3</sup> advantage

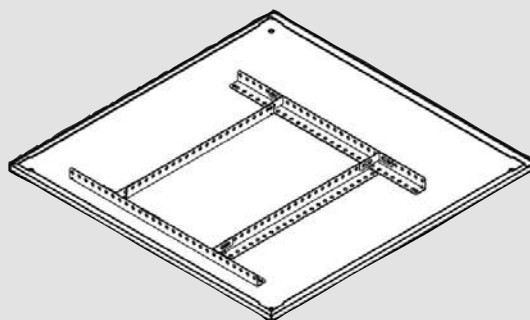

**Installation kit for XL<sup>3</sup> cabinets**

Kit Cat.No 0 205 29 for reinforcing the roof of the XL<sup>3</sup> cabinets for the installation of the Legrand interface to connect the busbar systems

The Super Compact – SCP range can be easily and immediately combined with the Legrand XL<sup>3</sup> 4000 cabinets  
The reinforcement kit enables you to install any type of unit to the board onto the roof of the XL<sup>3</sup> structure in a quick and easy way

Upon request, and with the specific measurements, custom made connections between the SCP interface and the DMX air-circuit breaker can be supplied for installation in the XL<sup>3</sup> cabinets

The safety and the operational efficiency of the Legrand system are guaranteed by the system certification, achieved after rigorous tests carried out in the most important international laboratories.

For more details about the XL<sup>3</sup>, please refer to the general Legrand catalogue

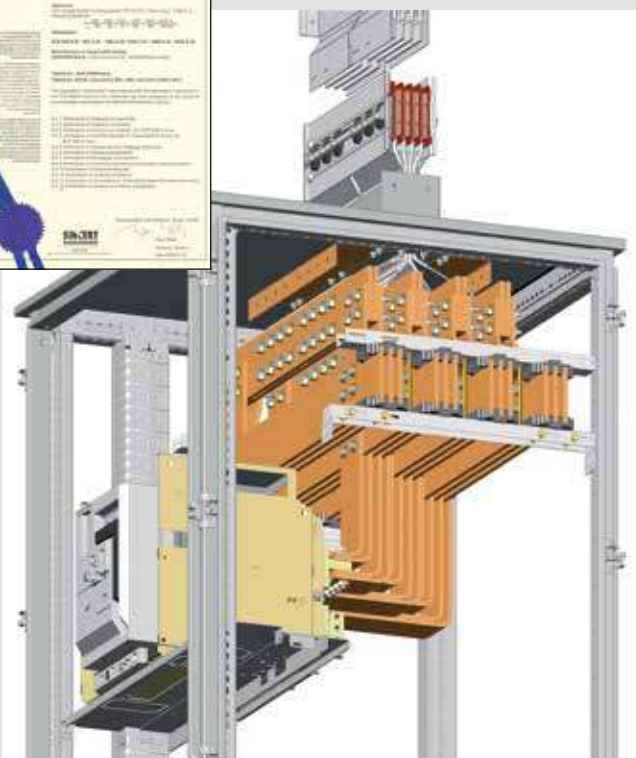

# Super compact (SCP)

## technical informations

### General features

The Super Compact SCP line is available in the standard range: From **630A to 5000A with aluminum alloy** conductors and **from 800A to 6300A with copper conductors**. The super-compact dimensions of the SCP enhance **its resistance to short circuit stresses**; in addition, they can reduce the impedance of the circuit by controlling the voltage drops and allow for the installation of high power electrical systems, even in extremely confined spaces. SCP is available with **a wide selection of tap-off boxes that range from 63A up to 1250A**, thus allowing you to locally protect and feed different types of loads by housing protective devices such as fuses, MCCBs and motorised switches. SCP is not only in **compliance with the harmonised Standards CEI EN 61439-6** but also answers specifically to many clients needs for more severe conditions of use. Thus **the rated current** of Legrand's busbar trunking systems is **always referred to the average ambient temperature of 40 °C** against the 35 °C required by the Standard, thus providing the markets with suitably **upgraded** products. The nominal range of all SCP Super-Compact busbars is guaranteed both for horizontal installations (flat and edgewise) and for vertical installations without downgrading. SCP busbar trunking systems are designed so that they can **be maintenance-free**, except for the periodic and compulsory inspections required by the Standard IEC 60364. The tightening torque inspection of the junction can be carried out by qualified personnel, even when the busbar is energized.

### Structural features

The outer casing of the SCP line consists of four C-ribbed section bars, bordered and riveted (thickness 1.5mm), **with excellent mechanical, electric and heat loss efficiency. The sheetmetal is made of hot galvanized steel**, treated according to UNI EN10327 and **painted with RAL7035 resins with a high resistance to chemical agents. The standard degree of protection is IP55, on request IP65 (only for transport of energy)**; also, with certain accessories, it can also be installed outdoors. The busbar conductors have a rectangular cross section with rounded corners; there are two versions:

- **Electrolytic copper ETP 99.9 UNI EN13601**
- **Aluminum alloy** treated over the entire surface with **5 galvanic processes** (copper plating + tin plating)

The insulation between bars is ensured by a **double sheath made with polyester film** (total thickness 0.4 mm) **class B (130°C), class F (155°C)** thermal resistance available on request. All plastic components have a **V1 self-extinguishing degree** (as per UL94); they are fire retardant and comply with the glow-wire test according to standards. The SCP line is **Halogen Free**. In order to facilitate storage operations especially to reduce the installation time, the straight elements, trunking components as well as all the components of the SCP Super Compact line are **supplied with a monobloc pre-installed at the factory**. The junction contact is ensured by **tin plated aluminium for SCP Al and copper for SCP Cu for each phase**, insulated with red **class F thermosetting plastic material**. The **monobloc** has **shearhead bolts**: after tightening the nuts with a standard wrench, the outer head will break at the correct torque value, hence giving you the certainty that the connection has been made properly so as to guarantee safety and maximum performance over time. Finally, in order to completely verify the insulation level, every element with a monobloc undergoes an **insulation test** (phase-phase, phase-PE) at the factory with a test voltage of 3500 Vac for 1.5 seconds.

RATED CURRENT OF SCP BARS (A)											
Al	630	800	1000	1250	1600	2000	2500	3200	4000	5000	
Single bar						Double bar			Transport		
Cu	800	1000	1250	1600	2000	2500	3200	4000	5000	6300	
Single bar						Double bar			Transport		

### Standard versions:

#### SCP line with 4 conductors 3P+N+PE, 3P+PEN, 3P+FE+PE

**Note:** For dimension H, see technical data section  
**PE:** Protection Earth  
**FE:** Functional Earth (Clean Earth)

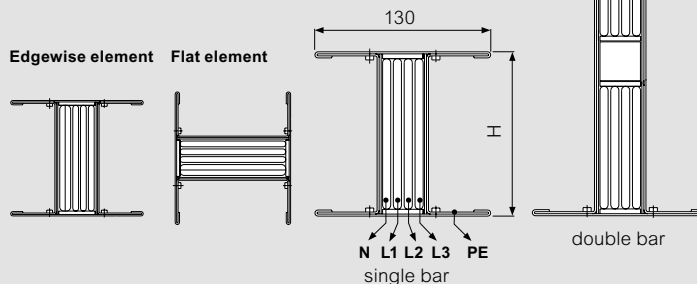

#### SCP5 line with 5 conductors 3P+N+FE+PE

**Note:** For dimension H, see technical data section  
**PE:** Protection Earth  
**FE:** Functional Earth (Clean Earth)

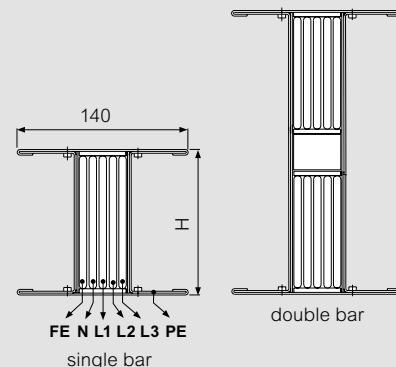

#### SCP2N 200% neutral line 3P+2N+PE

**Note:** For dimension H, see technical data section  
**PE:** Protection Earth  
**2N:** 200% neutral

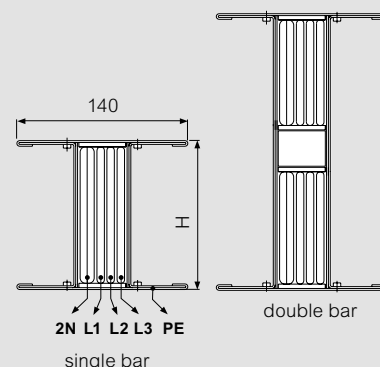

Special versions on request

# Super compact (SCP)

## technical data

### SCP AI (3 Conductors)

	In [A]	3P+PE									
		630	800	1000	1250	1600	2000	2500	3200	4000	5000**
Rated current	In [A]	630	800	1000	1250	1600	2000	2500	3200	4000	5000**
Overall dimension of the busbars	L x H [mm]	125x130	125x130	125x130	125x130	125x170	125x220	125x380	125x440	125x480	
Operational voltage	Ue [V]	1000	1000	1000	1000	1000	1000	1000	1000	1000	1000
Insulation voltage	Ui [V]	1000	1000	1000	1000	1000	1000	1000	1000	1000	1000
Frequency	f [Hz]	50/60	50/60	50/60	50/60	50/60	50/60	50/60	50/60	50/60	50/60
Rated short-time current (1 s)	Icw [kA]rms	36	42	50	75	80	80	150	160	160	160
Peak current	Ipk [kA]	75,6	88,2	110	165	176	176	330	352	352	352
Rated short-time current of the neutral bar (1 s)	Icw [kA]rms	-	-	-	-	-	-	-	-	-	-
Peak current of the neutral bar	Ipk [kA]	-	-	-	-	-	-	-	-	-	-
Rated short-time current of the protective circuit (1 s)	Icw [kA]rms	21,6	25,2	30	45	48	48	90	96	96	96
Peak current of the protective circuit	Ipk [kA]	48	55	66	99	106	106	198	211	211	211
Phase resistance	R20 [mΩ/m]	0,077	0,057	0,057	0,046	0,033	0,025	0,021	0,016	0,013	0,010
Phase reactance (50 Hz)	X [mΩ/m]	0,023	0,017	0,017	0,015	0,014	0,011	0,006	0,006	0,006	0,003
Phase impedance	Z [mΩ/m]	0,080	0,060	0,060	0,048	0,035	0,028	0,022	0,017	0,014	0,011
Phase resistance at thermal conditions	Rt [mΩ/m]	0,084	0,063	0,068	0,055	0,039	0,031	0,024	0,019	0,016	0,012
Phase impedance at thermal conditions	Z [mΩ/m]	0,087	0,066	0,070	0,057	0,041	0,033	0,025	0,020	0,017	0,0123
Neutral resistance	R20 [mΩ/m]	-	-	-	-	-	-	-	-	-	-
Resistance of the protective bar (PE 1)	RPE [mΩ/m]	0,158	0,158	0,158	0,158	0,143	0,128	0,094	0,086	0,081	0,047
Resistance of the protective bar (PE 2)	RPE [mΩ/m]	0,037	0,037	0,037	0,037	0,029	0,021	0,017	0,014	0,012	0,008
Resistance of the protective bar (PE 3)	RPE [mΩ/m]	0,056	0,056	0,056	0,056	0,045	0,036	0,026	0,022	0,020	0,013
Reactance of the protective bar (50 Hz)	XPE [mΩ/m]	0,080	0,078	0,078	0,048	0,039	0,028	0,020	0,015	0,016	0,010
Resistance of the fault loop (PE 1)	Ro [mΩ/m]	0,242	0,221	0,226	0,213	0,181	0,158	0,118	0,105	0,097	0,060
Resistance of the fault loop (PE 2)	Ro [mΩ/m]	0,121	0,101	0,106	0,093	0,068	0,052	0,041	0,033	0,028	0,021
Resistance of the fault loop (PE 3)	Ro [mΩ/m]	0,140	0,119	0,124	0,111	0,083	0,067	0,050	0,041	0,036	0,025
Reactance of the fault loop (50 Hz)	Xo [mΩ/m]	0,103	0,095	0,095	0,063	0,053	0,039	0,026	0,021	0,022	0,013
Impedance of the fault loop (PE 1)	Zo [mΩ/m]	0,263	0,241	0,245	0,222	0,189	0,163	0,121	0,107	0,100	0,061
Impedance of the fault loop (PE 2)	Zo [mΩ/m]	0,159	0,138	0,142	0,112	0,086	0,065	0,048	0,039	0,035	0,025
Impedance of the fault loop (PE 3)	Zo [mΩ/m]	0,174	0,152	0,156	0,128	0,099	0,077	0,056	0,046	0,042	0,029
Zero-sequence short-circuit resistance phase - N	Ro [mΩ/m]	-	-	-	-	-	-	-	-	-	-
Zero-sequence short-circuit reactance phase - N	Xo [mΩ/m]	-	-	-	-	-	-	-	-	-	-
Zero-sequence short-circuit impedance phase - N	Zo [mΩ/m]	-	-	-	-	-	-	-	-	-	-
Zero-sequence short-circuit resistance phase - PE	Ro [mΩ/m]	0,581	0,519	0,519	0,369	0,321	0,27	0,217	0,196	0,164	0,109
Zero-sequence short-circuit reactance phase - PE	Xo [mΩ/m]	0,263	0,229	0,229	0,191	0,175	0,212	0,155	0,148	0,146	0,078
Zero-sequence short-circuit impedance phase - PE	Zo [mΩ/m]	0,638	0,567	0,567	0,416	0,366	0,343	0,267	0,246	0,220	0,133
Voltage drop with distributed load	$\Delta V [V/m/A] 10^{-6} \cos\varphi = 0.70$	65,2	48,9	51,9	42,7	32,1	25,4	18,2	15,2	13,5	**
	$\Delta V [V/m/A] 10^{-6} \cos\varphi = 0.75$	67,8	50,9	54,1	44,4	33,1	26,3	18,9	15,7	13,9	**
	$\Delta V [V/m/A] 10^{-6} \cos\varphi = 0.80$	70,2	52,8	56,2	46,0	34,0	27,0	19,6	16,2	14,3	**
	$\Delta V [V/m/A] 10^{-6} \cos\varphi = 0.85$	72,4	54,4	58,1	47,4	34,8	27,6	20,3	16,7	14,6	**
	$\Delta V [V/m/A] 10^{-6} \cos\varphi = 0.90$	74,2	55,8	59,7	48,7	35,4	28,1	20,9	17,0	14,8	**
	$\Delta V [V/m/A] 10^{-6} \cos\varphi = 0.95$	75,4	56,8	60,8	49,4	35,5	28,2	21,3	17,2	14,9	**
	$\Delta V [V/m/A] 10^{-6} \cos\varphi = 1.00$	72,8	54,9	59,2	47,8	33,4	26,6	20,7	16,4	13,9	**
Weight (PE 1)	p [kg/m]	16,7	16,6	16,6	17,7	22,1	27,0	38,1	45,3	51,2	61,0
Weight (PE 2)	p [kg/m]	19,9	19,8	19,8	20,9	26,3	33,2	45,7	54,4	62,7	73,1
Weight (PE 3)	p [kg/m]	17,7	17,6	17,6	18,7	23,5	28,8	40,6	48,3	54,6	64,9
Fire load	[kWh/m]	3,38	4,13	4,13	4,50	6,38	7,88	12,00	14,25	15,75	19,20
Degree of protection	IP	55	55	55	55	55	55	55	55	55	55
Insulation material thermal resistance class		B/F*	B/F*	B/F*	B/F*	B/F*	B/F*	B/F*	B/F*	B/F*	B/F*
Losses for the Joule effect at nominal current	P [W/m]	100	122	205	260	300	363	455	592	790	935
Ambient temperature min/MAX	[°C]	-5/50	-5/50	-5/50	-5/50	-5/50	-5/50	-5/50	-5/50	-5/50	-5/50

#### - Regulations and conformity:

IEC/EN 61439-6;

#### - Product suitable for Constant/Cyclic Warm, humid climates:

- EC 60068 2-11: Environmental tests Part 2-11:

Tests - Test Ka: Salt mist

- IEC 60068 2-30: Environmental tests Part 2-30: Tests - Test Db:

Damp heat, cyclic (12 h + 12 h cycle)

#### - Degree of protection:

IP55, on request IP65; IPx7 carrying lines available with accessories, on request

#### - Insulation and surface treatment of the conductors:

Insulated conductors for the whole length, tin-plated aluminium conductors and copper without galvanic treatment

#### - Busbar casing material:

1.5mm galvanized steel plate, pre-painted or stainless steel (available, if required, with special paint and/or with thickness 2 mm or with stainless steel casing)

#### Note:

\* Class F thermal resistance (155°C) available on request

\*\*5000A AI - Only for transport of energy (for calculation of voltage drop, look at dedicated chapter "Choosing Guide")



PE 1  
Standard version



PE 2  
Extra earth - COPPER



PE 3  
Extra earth - ALUMINUM  
SCP AI 3L+N+50%PE  
(available on request)

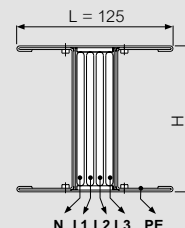

In: rated current referred to a room temperature of 40°C  
 $\Delta V$ : for calculations, see on chapter "Choosing Guide"

# Super compact (SCP)

## technical data

### SCP CU (3 Conductors)

	In [A]	3P+PE									
		800	1000	1250	1600	2000	2500	3200	4000	5000	6300**
Rated current	In [A]	800	1000	1250	1600	2000	2500	3200	4000	5000	6300**
Overall dimension of the busbars	L x H [mm]	125x130	125x130	125x130	125x170	125x170	125x220	125x380	125x440	125x480	125x480
Operational voltage	Ue [V]	1000	1000	1000	1000	1000	1000	1000	1000	1000	1000
Insulation voltage	Ui [V]	1000	1000	1000	1000	1000	1000	1000	1000	1000	1000
Frequency	f [Hz]	50/60	50/60	50/60	50/60	50/60	50/60	50/60	50/60	50/60	50/60
Rated short-time current (1 s)	Icw [kA]rms	45	50	60	85	88	88	170	176	176	176
Peak current	Ipk [kA]	95	110	132	187	194	194	374	387	387	387
Rated short-time current of the neutral bar (1 s)	Icw [kA]rms	-	-	-	-	-	-	-	-	-	-
Peak current of the neutral bar	Ipk [kA]	-	-	-	-	-	-	-	-	-	-
Rated short-time current of the protective circuit (1 s)	Icw [kA]rms	27	30	36	51	53	53	102	106	106	106
Peak current of the protective circuit	Ipk [kA]	57	66	79	112	116	116	224	232	232	232
Phase resistance	R20 [mΩ/m]	0,039	0,030	0,030	0,022	0,018	0,014	0,011	0,009	0,007	0,006
Phase reactance (50 Hz)	X [mΩ/m]	0,023	0,017	0,017	0,015	0,014	0,011	0,007	0,006	0,006	0,004
Phase impedance	Z [mΩ/m]	0,045	0,035	0,035	0,027	0,023	0,018	0,013	0,011	0,009	0,007
Phase resistance at thermal conditions	Rt [mΩ/m]	0,042	0,035	0,037	0,027	0,022	0,017	0,013	0,011	0,009	0,007
Phase impedance at thermal conditions	Z [mΩ/m]	0,048	0,039	0,041	0,031	0,026	0,020	0,015	0,013	0,010	0,007
Neutral resistance	R20 [mΩ/m]	-	-	-	-	-	-	-	-	-	-
Resistance of the protective bar (PE 1)	RPE [mΩ/m]	0,158	0,158	0,158	0,143	0,143	0,128	0,094	0,086	0,081	0,047
Resistance of the protective bar (PE 2)	RPE [mΩ/m]	0,037	0,037	0,037	0,030	0,029	0,021	0,017	0,014	0,012	0,008
Resistance of the protective bar (PE 3)	RPE [mΩ/m]	0,056	0,056	0,056	0,046	0,045	0,036	0,026	0,022	0,020	0,013
Reactance of the protective bar (50 Hz)	XPE [mΩ/m]	0,054	0,054	0,054	0,044	0,044	0,032	0,022	0,017	0,016	0,011
Resistance of the fault loop (PE 1)	Ro [mΩ/m]	0,200	0,192	0,195	0,170	0,165	0,145	0,107	0,097	0,090	0,054
Resistance of the fault loop (PE 2)	Ro [mΩ/m]	0,080	0,072	0,074	0,057	0,052	0,038	0,030	0,025	0,020	0,015
Resistance of the fault loop (PE 3)	Ro [mΩ/m]	0,098	0,090	0,093	0,073	0,067	0,053	0,039	0,033	0,028	0,019
Reactance of the fault loop (50 Hz)	Xo [mΩ/m]	0,077	0,071	0,071	0,059	0,058	0,043	0,029	0,023	0,022	0,015
Impedance of the fault loop (PE 1)	Zo [mΩ/m]	0,214	0,205	0,207	0,180	0,175	0,151	0,111	0,100	0,093	0,055
Impedance of the fault loop (PE 2)	Zo [mΩ/m]	0,111	0,101	0,103	0,082	0,078	0,057	0,041	0,034	0,030	0,021
Impedance of the fault loop (PE 3)	Zo [mΩ/m]	0,125	0,115	0,117	0,094	0,089	0,068	0,048	0,041	0,036	0,024
Zero-sequence short-circuit resistance phase - N	Ro [mΩ/m]	-	-	-	-	-	-	-	-	-	-
Zero-sequence short-circuit reactance phase - N	Xo [mΩ/m]	-	-	-	-	-	-	-	-	-	-
Zero-sequence short-circuit impedance phase - N	Zo [mΩ/m]	-	-	-	-	-	-	-	-	-	-
Zero-sequence short-circuit resistance phase - PE	Ro [mΩ/m]	0,507	0,429	0,429	0,331	0,283	0,221	0,177	0,178	0,144	0,089
Zero-sequence short-circuit reactance phase - PE	Xo [mΩ/m]	0,201	0,177	0,177	0,143	0,15	0,124	0,111	0,094	0,086	0,056
Zero-sequence short-circuit impedance phase - PE	Zo [mΩ/m]	0,545	0,464	0,464	0,361	0,320	0,253	0,209	0,201	0,168	0,104
Voltage drop with distributed load	$\Delta V$ [V/m/A]10 <sup>-6</sup> cosφ = 0.70	40,0	31,5	33,0	25,6	22,1	17,2	12,2	10,6	8,9	**
	$\Delta V$ [V/m/A]10 <sup>-6</sup> cosφ = 0.75	40,8	32,2	33,8	26,1	22,4	17,4	12,5	10,8	9,0	**
	$\Delta V$ [V/m/A]10 <sup>-6</sup> cosφ = 0.80	41,4	32,8	34,5	26,5	22,7	17,6	12,7	10,9	9,0	**
	$\Delta V$ [V/m/A]10 <sup>-6</sup> cosφ = 0.85	41,8	33,3	35,1	26,7	22,7	17,6	12,8	11,1	9,0	**
	$\Delta V$ [V/m/A]10 <sup>-6</sup> cosφ = 0.90	41,8	33,4	35,3	26,7	22,6	17,5	12,8	11,1	8,9	**
	$\Delta V$ [V/m/A]10 <sup>-6</sup> cosφ = 0.95	41,2	33,1	35,1	26,2	22,1	17,1	12,6	10,9	8,6	**
$\Delta V$ [V/m/A]10 <sup>-6</sup> cosφ = 1.00	36,8	30,0	32,1	23,4	19,2	14,8	11,3	9,8	7,4	**	
Weight (PE 1)	p [kg/m]	27	29	29	37	41	52	72	84	103	114
Weight (PE 2)	p [kg/m]	30	32	32	40	45	58	79	93	114	127
Weight (PE 3)	p [kg/m]	28	30	30	38	43	54	74	87	106	118
Fire load	[kWh/m]	3,4	4,1	4,1	6,0	6,2	7,9	12,0	14,3	15,8	19
Degree of protection	IP	55	55	55	55	55	55	55	55	55	55
Insulation material thermal resistance class		B/F*	B/F*	B/F*	B/F*	B/F*	B/F*	B/F*	B/F*	B/F*	B/F*
Losses for the Joule effect at nominal current	P [W/m]	81	104	174	207	265	319	399	541	636	773
Ambient temperature min/MAX	[°C]	-5/50	-5/50	-5/50	-5/50	-5/50	-5/50	-5/50	-5/50	-5/50	-5/50

- **Regulations and conformity:**  
IEC/EN 61439-6;
- **Product suitable for Constant/Cyclic Warm, humid climates:**  
- EC 60068 2-11: Environmental tests Part 2-11:  
Tests – Test Ka: Salt mist  
- IEC 60068 2-30: Environmental tests Part 2-30: Tests – Test Db:  
Damp heat, cyclic (12 h + 12 h cycle)
- **Degree of protection:**  
IP55, on request IP65; IPx7 carrying lines available with accessories, on request
- **Insulation and surface treatment of the conductors:**  
Insulated conductors for the whole length, tin-plated aluminium conductors and copper without galvanic treatment
- **Busbar casing material:**  
1,5mm galvanized steel plate, pre-painted or stainless steel (available, if required, with special paint and/or with thickness 2 mm or with stainless steel casing)

**Note:**  
\* Class F thermal resistance (155°C) available on request  
\*\*6300A Cu – Only for transport of energy (for calculation of voltage drop, look at dedicated chapter "Choosing Guide")



PE 1  
Standard version



PE 2  
Extra earth - COPPER  
SCP Cu 3L+N+50%PE  
(tinned copper conductors  
available on request)



PE 3  
Extra earth - ALUMINUM

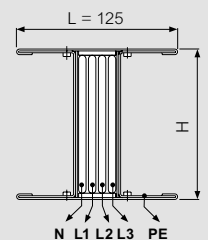

In: rated current referred to a room temperature of 40°C  
ΔV: for calculations, see on chapter "Choosing Guide"

## SCP AI (4 Conductors)

	In [A]	3P+N+PE									
		630	800	1000	1250	1600	2000	2500	3200	4000	5000**
Rated current	In [A]	630	800	1000	1250	1600	2000	2500	3200	4000	5000**
Overall dimension of the busbars	L x H [mm]	130x130	130x130	130x130	130x130	130x170	130x220	130x380	130x440	130x480	
Operational voltage	Ue [V]	1000	1000	1000	1000	1000	1000	1000	1000	1000	1000
Insulation voltage	Ui [V]	1000	1000	1000	1000	1000	1000	1000	1000	1000	1000
Frequency	f [Hz]	50/60	50/60	50/60	50/60	50/60	50/60	50/60	50/60	50/60	50/60
Rated short-time current (1 s)	Icw [kA]rms	36	42	50	75	80	80	150	160	160	160
Peak current	Ipk [kA]	76	88	110	165	176	176	330	352	352	352
Rated short-time current of the neutral bar (1 s)	Icw [kA]rms	22	25	30	45	48	48	90	96	96	96
Peak current of the neutral bar	Ipk [kA]	48	55	66	99	106	106	198	211	211	211
Rated short-time current of the protective circuit (1 s)	Icw [kA]rms	22	25	30	45	48	48	90	96	96	96
Peak current of the protective circuit	Ipk [kA]	48	55	66	99	106	106	198	211	211	211
Phase resistance	R20 [mΩ/m]	0.077	0.057	0.057	0.046	0.033	0.025	0.021	0.016	0.013	0.011
Phase reactance (50 Hz)	X [mΩ/m]	0.023	0.017	0.017	0.015	0.014	0.011	0.006	0.006	0.006	0.003
Phase impedance	Z [mΩ/m]	0.080	0.059	0.059	0.048	0.036	0.027	0.022	0.017	0.014	0.011
Phase resistance at thermal conditions	Rt [mΩ/m]	0.084	0.063	0.068	0.055	0.039	0.030	0.024	0.019	0.016	0.012
Phase impedance at thermal conditions	Z [mΩ/m]	0.087	0.066	0.070	0.057	0.041	0.032	0.025	0.020	0.018	0.013
Neutral resistance	R20 [mΩ/m]	0.077	0.057	0.057	0.046	0.033	0.025	0.021	0.016	0.013	0.011
Resistance of the protective bar (PE 1)	RPE [mΩ/m]	0.125	0.125	0.125	0.125	0.113	0.101	0.075	0.069	0.065	0.038
Resistance of the protective bar (PE 2)	RPE [mΩ/m]	0.036	0.036	0.036	0.036	0.028	0.023	0.014	0.012	0.011	0.007
Resistance of the protective bar (PE 3)	RPE [mΩ/m]	0.050	0.050	0.050	0.050	0.041	0.033	0.021	0.018	0.017	0.011
Reactance of the protective bar (50 Hz)	XPE [mΩ/m]	0.080	0.078	0.078	0.048	0.039	0.028	0.020	0.015	0.016	0.010
Resistance of the fault loop (PE 1)	Ro [mΩ/m]	0.209	0.188	0.193	0.180	0.152	0.131	0.099	0.088	0.081	0.050
Resistance of the fault loop (PE 2)	Ro [mΩ/m]	0.120	0.099	0.104	0.091	0.067	0.053	0.038	0.031	0.027	0.019
Resistance of the fault loop (PE 3)	Ro [mΩ/m]	0.134	0.113	0.118	0.105	0.080	0.063	0.045	0.037	0.033	0.023
Reactance of the fault loop (50 Hz)	Xo [mΩ/m]	0.10	0.10	0.10	0.06	0.05	0.04	0.03	0.02	0.02	0.01
Impedance of the fault loop (PE 1)	Zo [mΩ/m]	0.233	0.211	0.215	0.191	0.161	0.137	0.103	0.091	0.084	0.052
Impedance of the fault loop (PE 2)	Zo [mΩ/m]	0.158	0.137	0.141	0.111	0.085	0.066	0.046	0.038	0.035	0.023
Impedance of the fault loop (PE 3)	Zo [mΩ/m]	0.169	0.148	0.152	0.123	0.096	0.074	0.052	0.043	0.040	0.026
Zero-sequence short-circuit resistance phase - N	Ro [mΩ/m]	0.306	0.257	0.257	0.238	0.172	0.140	0.107	0.080	0.070	0.054
Zero-sequence short-circuit reactance phase - N	Xo [mΩ/m]	0.174	0.160	0.160	0.128	0.106	0.108	0.083	0.073	0.060	0.042
Zero-sequence short-circuit impedance phase - N	Zo [mΩ/m]	0.352	0.303	0.303	0.270	0.202	0.177	0.135	0.108	0.092	0.068
Zero-sequence short-circuit resistance phase - PE	Ro [mΩ/m]	0.581	0.519	0.519	0.369	0.321	0.270	0.217	0.196	0.164	0.109
Zero-sequence short-circuit reactance phase - PE	Xo [mΩ/m]	0.263	0.229	0.229	0.191	0.175	0.212	0.155	0.148	0.146	0.078
Zero-sequence short-circuit impedance phase - PE	Zo [mΩ/m]	0.638	0.567	0.567	0.416	0.366	0.343	0.267	0.246	0.220	0.133
Voltage drop with distributed load	$\Delta V$ [V/m/A] $10^{-6} \cos\varphi = 0.70$	65.3	48.9	51.9	42.9	32.3	25.1	18.4	15.4	13.7	**
	$\Delta V$ [V/m/A] $10^{-6} \cos\varphi = 0.75$	67.9	50.9	54.1	44.6	33.4	25.9	19.2	16.0	14.1	**
	$\Delta V$ [V/m/A] $10^{-6} \cos\varphi = 0.80$	70.3	52.7	56.1	46.2	34.3	26.7	19.9	16.5	14.5	**
	$\Delta V$ [V/m/A] $10^{-6} \cos\varphi = 0.85$	72.5	54.4	58.0	47.7	35.1	27.3	20.6	16.9	14.9	**
	$\Delta V$ [V/m/A] $10^{-6} \cos\varphi = 0.90$	74.3	55.8	59.6	48.9	35.7	27.7	21.2	17.3	15.1	**
	$\Delta V$ [V/m/A] $10^{-6} \cos\varphi = 0.95$	75.5	56.7	60.8	49.7	35.9	27.8	21.6	17.5	15.2	**
$\Delta V$ [V/m/A] $10^{-6} \cos\varphi = 1.00$	72.9	54.9	59.1	48.0	33.8	26.2	21.0	16.7	14.3	**	
Weight (PE 1)	p [kg/m]	17.3	17.0	17.0	18.7	20.3	30.7	43.7	52.3	62.7	87.4
Weight (PE 2)	p [kg/m]	20.8	20.5	20.5	23.2	24.9	36.7	53.9	64.3	75.7	107.8
Weight (PE 3)	p [kg/m]	18.4	18.1	18.1	20.8	21.8	32.6	46.9	56.1	66.8	93.8
Fire load	[kWh/m]	4.5	5.5	5.5	6.0	8.5	10.5	16.0	19.0	21.0	32.0
Degree of protection	IP	55	55	55	55	55	55	55	55	55	55
Insulation material thermal resistance class		B/F*	B/F*	B/F*	B/F*	B/F*	B/F*	B/F*	B/F*	B/F*	B/F*
Losses for the Joule effect at nominal current	P [W/m]	100	122	205	260	300	363	455	592	790	935
Ambient temperature min/MAX	[°C]	-5/50	-5/50	-5/50	-5/50	-5/50	-5/50	-5/50	-5/50	-5/50	-5/50

### - Regulations and conformity:

- IEC/EN 61439-6;
- **Product suitable for Constant/Cyclic Warm, humid climates:**
  - EC 60068 2-11: Environmental tests Part 2-11: Tests - Test Ka: Salt mist
  - IEC 60068 2-30: Environmental tests Part 2-30: Tests - Test Db: Damp heat, cyclic (12 h + 12 h cycle)

### - Degree of protection:

- IP55, on request IP65; IPx7 carrying lines available with accessories, on request

### - Insulation and surface treatment of the conductors:

- Insulated conductors for the whole length, tin-plated aluminium conductors and copper without galvanic treatment

### - Busbar casing material:

- 1.5mm galvanized steel plate, pre-painted or stainless steel (available, if required, with special paint and/or with thickness 2 mm or with stainless steel casing)

### Note:

- \* Class F thermal resistance (155°C) available on request
- \*\*5000A AI – Only for transport of energy (for calculation of voltage drop, look at dedicated chapter "Choosing Guide")



PE 1 Standard version



PE 2 Extra earth - COPPER



PE 3 Extra earth - ALUMINUM SCP AI 3L+N+50%PE (available on request)

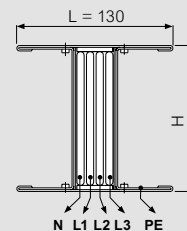

In: rated current referred to a room temperature of 40°C  
 $\Delta V$ : for calculations, see on chapter "Choosing Guide"

### SCP CU (4 Conductors)

		3P+N+PE									
		800	1000	1250	1600	2000	2500	3200	4000	5000	6300**
Rated current	$I_n$ [A]										
Overall dimension of the busbars	$L \times H$ [mm]	130x130	130x130	130x130	130x170	130x170	130x220	130x380	130x440	130x480	
Operational voltage	$U_e$ [V]	1000	1000	1000	1000	1000	1000	1000	1000	1000	1000
Insulation voltage	$U_i$ [V]	1000	1000	1000	1000	1000	1000	1000	1000	1000	1000
Frequency	$f$ [Hz]	50/60	50/60	50/60	50/60	50/60	50/60	50/60	50/60	50/60	50/60
Rated short-time current (1 s)	$I_{cw}$ [kA] <sub>rms</sub>	45	50	60	85	88	88	170	176	176	176
Peak current	$I_{pk}$ [kA]	95	110	132	187	194	194	374	387	387	387
Rated short-time current of the neutral bar (1 s)	$I_{cw}$ [kA] <sub>rms</sub>	27	30	36	51	53	53	102	106	106	106
Peak current of the neutral bar	$I_{pk}$ [kA]	57	66	79	112	116	116	224	232	232	232
Rated short-time current of the protective circuit (1 s)	$I_{cw}$ [kA] <sub>rms</sub>	27	30	36	51	53	53	102	106	106	106
Peak current of the protective circuit	$I_{pk}$ [kA]	57	66	79	112	116	116	224	232	232	232
Phase resistance	$R_{20}$ [mΩ/m]	0.039	0.030	0.030	0.022	0.018	0.014	0.011	0.009	0.007	0.006
Phase reactance (50 Hz)	$X$ [mΩ/m]	0.023	0.017	0.017	0.015	0.014	0.011	0.007	0.006	0.006	0.004
Phase impedance	$Z$ [mΩ/m]	0.045	0.035	0.035	0.027	0.023	0.018	0.013	0.011	0.009	0.007
Phase resistance at thermal conditions	$R_t$ [mΩ/m]	0.042	0.035	0.037	0.027	0.022	0.017	0.013	0.011	0.008	0.006
Phase impedance at thermal conditions	$Z$ [mΩ/m]	0.048	0.039	0.041	0.031	0.026	0.020	0.015	0.013	0.010	0.007
Neutral resistance	$R_{20}$ [mΩ/m]	0.039	0.030	0.030	0.022	0.018	0.014	0.011	0.009	0.007	0.006
Resistance of the protective bar (PE 1)	$R_{PE}$ [mΩ/m]	0.125	0.125	0.125	0.113	0.113	0.101	0.075	0.069	0.065	0.038
Resistance of the protective bar (PE 2)	$R_{PE}$ [mΩ/m]	0.036	0.036	0.036	0.028	0.028	0.023	0.014	0.012	0.011	0.007
Resistance of the protective bar (PE 3)	$R_{PE}$ [mΩ/m]	0.050	0.050	0.050	0.041	0.041	0.033	0.021	0.018	0.017	0.011
Reactance of the protective bar (50 Hz)	$X_{PE}$ [mΩ/m]	0.054	0.054	0.054	0.044	0.044	0.032	0.022	0.017	0.016	0.011
Resistance of the fault loop (PE 1)	$R_o$ [mΩ/m]	0.167	0.160	0.162	0.140	0.135	0.118	0.088	0.080	0.073	0.044
Resistance of the fault loop (PE 2)	$R_o$ [mΩ/m]	0.078	0.071	0.073	0.055	0.050	0.040	0.027	0.023	0.019	0.013
Resistance of the fault loop (PE 3)	$R_o$ [mΩ/m]	0.092	0.085	0.087	0.068	0.063	0.050	0.034	0.029	0.025	0.017
Reactance of the fault loop (50 Hz)	$X_o$ [mΩ/m]	0.077	0.071	0.071	0.059	0.058	0.043	0.029	0.023	0.022	0.015
Impedance of the fault loop (PE 1)	$Z_o$ [mΩ/m]	0.184	0.175	0.177	0.152	0.147	0.126	0.093	0.083	0.077	0.046
Impedance of the fault loop (PE 2)	$Z_o$ [mΩ/m]	0.110	0.100	0.102	0.081	0.077	0.059	0.040	0.033	0.029	0.020
Impedance of the fault loop (PE 3)	$Z_o$ [mΩ/m]	0.120	0.110	0.112	0.090	0.086	0.066	0.045	0.037	0.034	0.022
Zero-sequence short-circuit resistance phase - N	$R_o$ [mΩ/m] - N	0.170	0.155	0.155	0.115	0.120	0.098	0.083	0.071	0.062	0.042
Zero-sequence short-circuit reactance phase - N	$X_o$ [mΩ/m] - N	0.159	0.151	0.151	0.114	0.098	0.065	0.056	0.055	0.042	0.028
Zero-sequence short-circuit impedance phase - N	$Z_o$ [mΩ/m]	0.233	0.216	0.216	0.162	0.155	0.118	0.100	0.090	0.075	0.050
Zero-sequence short-circuit resistance phase - PE	$R_o$ [mΩ/m]	0.507	0.429	0.429	0.331	0.283	0.221	0.177	0.178	0.144	0.089
Zero-sequence short-circuit reactance phase - PE	$X_o$ [mΩ/m]	0.201	0.177	0.177	0.143	0.150	0.124	0.111	0.094	0.086	0.056
Zero-sequence short-circuit impedance phase - PE	$Z_o$ [mΩ/m]	0.545	0.464	0.464	0.361	0.320	0.253	0.209	0.201	0.168	0.104
Voltage drop with distributed load	$\Delta V$ [V/m/A] $10^{-6} \cos\varphi = 0.70$	39.9	31.5	33.0	25.6	22.1	17.1	12.2	10.5	8.9	**
	$\Delta V$ [V/m/A] $10^{-6} \cos\varphi = 0.75$	40.7	32.2	33.9	26.1	22.4	17.4	12.4	10.8	8.9	**
	$\Delta V$ [V/m/A] $10^{-6} \cos\varphi = 0.80$	41.3	32.8	34.6	26.5	22.6	17.5	12.6	10.9	9.0	**
	$\Delta V$ [V/m/A] $10^{-6} \cos\varphi = 0.85$	41.7	33.3	35.1	26.7	22.7	17.5	12.8	11.0	9.0	**
	$\Delta V$ [V/m/A] $10^{-6} \cos\varphi = 0.90$	41.7	33.4	35.4	26.7	22.5	17.4	12.8	11.0	8.9	**
	$\Delta V$ [V/m/A] $10^{-6} \cos\varphi = 0.95$	41.1	33.1	35.1	26.2	22.0	17.0	12.6	10.9	8.6	**
	$\Delta V$ [V/m/A] $10^{-6} \cos\varphi = 1.00$	36.7	30.0	32.2	23.3	19.1	14.7	11.2	9.8	7.3	**
Weight (PE 1)	$p$ [kg/m]	31	31	31	42	46	69	84	101	126	168
Weight (PE 2)	$p$ [kg/m]	35	35	35	47	51	70	94	114	139	188
Weight (PE 3)	$p$ [kg/m]	33	32	32	44	48	66	87	105	130	174
Fire load	[kWh/m]	4.5	5.5	5.5	8	8.2	10.5	16	19	21	32
Degree of protection	IP	55	55	55	55	55	55	55	55	55	55
Insulation material thermal resistance class		B/F*	B/F*	B/F*	B/F*	B/F*	B/F*	B/F*	B/F*	B/F*	B/F*
Losses for the Joule effect at nominal current	$P$ [W/m]	81	104	174	207	265	319	399	541	636	773
Ambient temperature min/MAX	[°C]	-5/50	-5/50	-5/50	-5/50	-5/50	-5/50	-5/50	-5/50	-5/50	-5/50

#### - Regulations and conformity:

IEC/EN 61439-6;

#### - Product suitable for Constant/Cyclic Warm, humid climates:

- EC 60068 2-11: Environmental tests Part 2-11:

Tests - Test Ka: Salt mist

- IEC 60068 2-30: Environmental tests Part 2-30: Tests - Test Db: Damp heat, cyclic (12 h + 12 h cycle)

#### - Degree of protection:

IP55, on request IP65; IPx7 carrying lines available with accessories, on request

#### - Insulation and surface treatment of the conductors:

Insulated conductors for the whole length, tin-plated aluminium conductors and copper without galvanic treatment

#### - Busbar casing material:

1.5mm galvanized steel plate, pre-painted or stainless steel (available, if required, with special paint and/or with thickness 2 mm or with stainless steel casing)

#### Note:

\* Class F thermal resistance (155°C) available on request  
\*\*6300A Cu - Only for transport of energy (for calculation of voltage drop, look at dedicated chapter "Choosing Guide")



PE 1  
Standard version



PE 2  
Extra earth - COPPER  
SCP Cu 3L+N+50%PE  
(tinned copper conductors  
available on request)



PE 3  
Extra earth - ALUMINUM

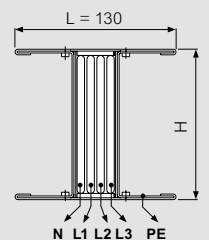

$I_n$ : rated current referred to a room temperature of 40°C  
 $\Delta V$ : for calculations, see on chapter "Choosing Guide"

## SCP5 AI - Clean Earth - 5 conductors

	In [A]	3P+N+PE+FE									
		630	800	1000	1250	1600	2000	2500	3200	4000	5000**
Rated current	In [A]	630	800	1000	1250	1600	2000	2500	3200	4000	5000**
Overall dimension of the busbars	L x H [mm]	140x130	140x130	140x130	140x130	140x170	140x220	140x380	140x440	140x480	
Operational voltage	Ue [V]	1000	1000	1000	1000	1000	1000	1000	1000	1000	1000
Insulation voltage	Ui [V]	1000	1000	1000	1000	1000	1000	1000	1000	1000	1000
Frequency	f [Hz]	50/60	50/60	50/60	50/60	50/60	50/60	50/60	50/60	50/60	50/60
Rated short-time current (1 s)	Icw [kA]rms	36	42	50	75	80	80	150	160	160	160
Peak current	Ipk [kA]	76	88	110	165	176	176	330	352	352	352
Rated short-time current of the neutral bar (1 s)	Icw [kA]rms	22	25	30	45	48	48	90	96	96	96
Peak current of the neutral bar	Ipk [kA]	48	55	66	99	106	106	198	211	211	211
Rated short-time current of the protective circuit (1 s)	Icw [kA]rms	22	25	30	45	48	48	90	96	96	96
Peak current of the protective circuit	Ipk [kA]	48	55	66	99	106	106	198	211	211	211
Phase resistance	R20 [mΩ/m]	0.077	0.057	0.057	0.046	0.033	0.025	0.021	0.016	0.013	0.011
Phase reactance (50 Hz)	X [mΩ/m]	0.023	0.017	0.017	0.015	0.014	0.011	0.006	0.006	0.006	0.003
Phase impedance	Z [mΩ/m]	0.080	0.059	0.059	0.048	0.036	0.027	0.022	0.017	0.014	0.011
Phase resistance at thermal conditions	Rt [mΩ/m]	0.084	0.063	0.068	0.055	0.039	0.030	0.024	0.019	0.016	0.012
Phase impedance at thermal conditions	Z [mΩ/m]	0.087	0.066	0.070	0.057	0.041	0.032	0.025	0.020	0.018	0.013
Neutral resistance	R20 [mΩ/m]	0.077	0.057	0.057	0.046	0.033	0.025	0.021	0.016	0.013	0.011
Functional earth resistance (FE)	R20 [mΩ/m]	0.077	0.057	0.057	0.046	0.033	0.025	0.021	0.016	0.013	0.011
Functional earth reactance (FE)	X [mΩ/m]	0.023	0.017	0.017	0.015	0.014	0.011	0.006	0.006	0.006	0.003
Resistance of the protective bar (PE type 1)	RPE [mΩ/m]	0.121	0.121	0.121	0.121	0.110	0.098	0.074	0.068	0.064	0.038
Resistance of the protective bar (PE type 2)	RPE [mΩ/m]	0.035	0.035	0.035	0.035	0.028	0.023	0.014	0.012	0.011	0.007
Resistance of the protective bar (PE type 3)	RPE [mΩ/m]	0.050	0.050	0.050	0.050	0.040	0.033	0.020	0.018	0.017	0.010
Reactance of the protective bar (50 Hz)	XPE [mΩ/m]	0.080	0.078	0.078	0.048	0.039	0.028	0.020	0.015	0.016	0.010
Resistance of the fault loop (PE 1)	Ro [mΩ/m]	0.131	0.102	0.107	0.089	0.064	0.050	0.041	0.032	0.027	0.021
Resistance of the fault loop (PE 2)	Ro [mΩ/m]	0.108	0.085	0.090	0.075	0.054	0.042	0.033	0.026	0.022	0.017
Resistance of the fault loop (PE 3)	Ro [mΩ/m]	0.115	0.090	0.095	0.079	0.057	0.044	0.034	0.028	0.024	0.018
Reactance of the fault loop (50 Hz)	Xo [mΩ/m]	0.10	0.10	0.10	0.06	0.05	0.04	0.03	0.02	0.02	0.01
Impedance of the fault loop (PE 1)	Zo [mΩ/m]	0.167	0.139	0.143	0.109	0.083	0.064	0.048	0.038	0.035	0.025
Impedance of the fault loop (PE 2)	Zo [mΩ/m]	0.149	0.128	0.131	0.098	0.076	0.057	0.042	0.034	0.031	0.021
Impedance of the fault loop (PE 3)	Zo [mΩ/m]	0.154	0.131	0.134	0.101	0.078	0.059	0.043	0.035	0.032	0.022
Zero-sequence short-circuit resistance phase - N	Ro [mΩ/m]	0.306	0.257	0.257	0.238	0.172	0.140	0.107	0.080	0.070	0.054
Zero-sequence short-circuit reactance phase - N	Xo [mΩ/m]	0.174	0.160	0.160	0.128	0.106	0.108	0.083	0.073	0.060	0.042
Zero-sequence short-circuit impedance phase - N	Zo [mΩ/m]	0.352	0.303	0.303	0.270	0.202	0.177	0.135	0.108	0.092	0.068
Zero-sequence short-circuit resistance phase - PE	Ro [mΩ/m]	0.468	0.387	0.387	0.246	0.213	0.173	0.113	0.107	0.070	0.057
Zero-sequence short-circuit reactance phase - PE	Xo [mΩ/m]	0.263	0.229	0.229	0.191	0.175	0.212	0.155	0.148	0.146	0.078
Zero-sequence short-circuit impedance phase - PE	Zo [mΩ/m]	0.537	0.450	0.450	0.311	0.276	0.274	0.192	0.183	0.162	0.096
Voltage drop with distributed load	$\Delta V$ [V/m/A] $10^{-6} \cos\varphi = 0.70$	65.3	48.9	51.9	42.9	32.3	25.1	18.4	15.4	13.7	**
	$\Delta V$ [V/m/A] $10^{-6} \cos\varphi = 0.75$	67.9	50.9	54.1	44.6	33.4	25.9	19.2	16.0	14.1	**
	$\Delta V$ [V/m/A] $10^{-6} \cos\varphi = 0.80$	70.3	52.7	56.1	46.2	34.3	26.7	19.9	16.5	14.5	**
	$\Delta V$ [V/m/A] $10^{-6} \cos\varphi = 0.85$	72.5	54.4	58.0	47.7	35.1	27.3	20.6	16.9	14.9	**
	$\Delta V$ [V/m/A] $10^{-6} \cos\varphi = 0.90$	74.3	55.8	59.6	48.9	35.7	27.7	21.2	17.3	15.1	**
	$\Delta V$ [V/m/A] $10^{-6} \cos\varphi = 0.95$	75.5	56.7	60.8	49.7	35.9	27.8	21.6	17.5	15.2	**
$\Delta V$ [V/m/A] $10^{-6} \cos\varphi = 1.00$	72.9	54.9	59.1	48.0	33.8	26.2	21.0	16.7	14.3	**	
Weight (PE 1)	p [kg/m]	21.6	21.3	21.3	23.4	25.4	38.4	54.6	65.4	78.4	109.3
Weight (PE 2)	p [kg/m]	23.0	22.8	22.8	26.4	28.6	41.4	60.1	72.1	84.9	134.8
Weight (PE 3)	p [kg/m]	20.6	20.4	20.4	24.0	25.5	37.4	53.1	64.0	76.0	117.3
Fire load	[kWh/m]	5.6	6.9	6.9	7.5	10.6	13.1	20.0	23.8	26.3	40.0
Degree of protection	IP	55	55	55	55	55	55	55	55	55	55
Insulation material thermal resistance class		B/F*	B/F*	B/F*	B/F*	B/F*	B/F*	B/F*	B/F*	B/F*	B/F*
Losses for the Joule effect at nominal current	P [W/m]	100	122	205	260	300	363	455	592	790	935
Ambient temperature min/MAX	[°C]	-5/50	-5/50	-5/50	-5/50	-5/50	-5/50	-5/50	-5/50	-5/50	-5/50

### Regulations and conformity:

- IEC/EN 61439-6;
- Product suitable for Constant/Cyclic Warm, humid climates:**
  - EC 60068 2-11: Environmental tests Part 2-11: Tests – Test Ka: Salt mist
  - IEC 60068 2-30: Environmental tests Part 2-30: Tests – Test Db: Damp heat, cyclic (12 h + 12 h cycle)
- Degree of protection:**
  - IP55, on request IP65; IPx7 carrying lines available with accessories, on request
- Insulation and surface treatment of the conductors:**
  - Insulated conductors for the whole length, tin-plated aluminium conductors and copper without galvanic treatment
- Busbar casing material:**
  - 1.5mm galvanized steel plate, pre-painted or stainless steel (available, if required, with special paint and/or with thickness 2 mm or with stainless steel casing)

### Note:

- \* Class F thermal resistance (155°C) available on request
- \*\*5000A AI – Only for transport of energy (for calculation of voltage drop, look at dedicated chapter "Choosing Guide")

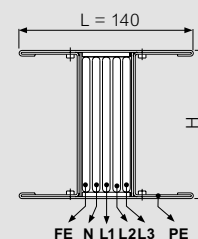
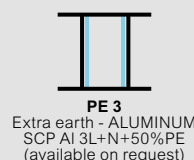
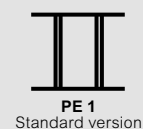

In: rated current referred to a room temperature of 40°C  
 $\Delta V$ : for calculations, see on chapter "Choosing Guide"

# Super compact (SCP)

## technical data (continued)

### SCP5 CU - Clean Earth - 5 conductors

Rated current	3P+N+PE+FE										
	In [A]	800	1000	1250	1600	2000	2500	3200	4000	5000	6300**
Overall dimension of the busbars	L x H [mm]	140x130	140x130	140x130	140x170	140x170	140x220	140x380	140x440	140x480	
Operational voltage	Ue [V]	1000	1000	1000	1000	1000	1000	1000	1000	1000	1000
Insulation voltage	Ui [V]	1000	1000	1000	1000	1000	1000	1000	1000	1000	1000
Frequency	f [Hz]	50/60	50/60	50/60	50/60	50/60	50/60	50/60	50/60	50/60	50/60
Rated short-time current (1 s)	Icw [kA] <sub>rms</sub>	45	50	60	85	88	88	170	176	176	176
Peak current	Ipk [kA]	95	110	132	187	194	194	374	387	387	387
Rated short-time current of the neutral bar (1 s)	Icw [kA] <sub>rms</sub>	27	30	36	51	53	53	102	106	106	106
Peak current of the neutral bar	Ipk [kA]	57	66	79	112	116	116	224	232	232	232
Rated short-time current of the protective circuit (1 s)	Icw [kA] <sub>rms</sub>	27	30	36	51	53	53	102	106	106	106
Peak current of the protective circuit	Ipk [kA]	57	66	79	112	116	116	224	232	232	232
Phase resistance	R <sub>20</sub> [mΩ/m]	0.039	0.030	0.030	0.022	0.018	0.014	0.011	0.009	0.007	0.006
Phase reactance (50 Hz)	X [mΩ/m]	0.023	0.017	0.017	0.015	0.014	0.011	0.007	0.006	0.006	0.004
Phase impedance	Z [mΩ/m]	0.045	0.035	0.035	0.027	0.023	0.018	0.013	0.011	0.009	0.007
Phase resistance at thermal conditions	R <sub>t</sub> [mΩ/m]	0.042	0.035	0.037	0.027	0.022	0.017	0.013	0.011	0.008	0.006
Phase impedance at thermal conditions	Z [mΩ/m]	0.048	0.039	0.041	0.031	0.026	0.020	0.015	0.013	0.010	0.007
Neutral resistance	R <sub>20</sub> [mΩ/m]	0.039	0.030	0.030	0.022	0.018	0.014	0.011	0.009	0.007	0.006
Functional earth resistance (FE)	R <sub>20</sub> [mΩ/m]	0.039	0.030	0.030	0.022	0.018	0.014	0.011	0.009	0.007	0.006
Functional earth reactance (FE)	X [mΩ/m]	0.023	0.017	0.017	0.015	0.014	0.011	0.007	0.006	0.006	0.004
Resistance of the protective bar (PE type 1)	R <sub>PE</sub> [mΩ/m]	0.125	0.125	0.125	0.113	0.113	0.101	0.075	0.069	0.065	0.038
Resistance of the protective bar (PE type 2)	R <sub>PE</sub> [mΩ/m]	0.036	0.036	0.036	0.028	0.028	0.023	0.014	0.012	0.011	0.007
Resistance of the protective bar (PE type 3)	R <sub>PE</sub> [mΩ/m]	0.050	0.050	0.050	0.041	0.041	0.033	0.021	0.018	0.017	0.011
Reactance of the protective bar (50 Hz)	X <sub>PE</sub> [mΩ/m]	0.054	0.054	0.054	0.044	0.044	0.032	0.022	0.017	0.016	0.011
Resistance of the fault loop (PE 1)	R <sub>o</sub> [mΩ/m]	0.072	0.059	0.062	0.045	0.038	0.029	0.023	0.019	0.015	0.011
Resistance of the fault loop (PE 2)	R <sub>o</sub> [mΩ/m]	0.061	0.051	0.054	0.039	0.033	0.026	0.019	0.016	0.013	0.010
Resistance of the fault loop (PE 3)	R <sub>o</sub> [mΩ/m]	0.064	0.054	0.056	0.041	0.035	0.027	0.020	0.017	0.013	0.010
Reactance of the fault loop (50 Hz)	X <sub>o</sub> [mΩ/m]	0.077	0.071	0.071	0.059	0.058	0.043	0.029	0.023	0.022	0.015
Impedance of the fault loop (PE 1)	Z <sub>o</sub> [mΩ/m]	0.105	0.092	0.094	0.074	0.069	0.052	0.037	0.030	0.026	0.018
Impedance of the fault loop (PE 2)	Z <sub>o</sub> [mΩ/m]	0.098	0.087	0.089	0.071	0.067	0.050	0.035	0.028	0.025	0.017
Impedance of the fault loop (PE 3)	Z <sub>o</sub> [mΩ/m]	0.100	0.089	0.090	0.072	0.068	0.051	0.035	0.029	0.026	0.018
Zero-sequence short-circuit resistance phase - N	R <sub>o</sub> [mΩ/m]	0.170	0.155	0.155	0.115	0.120	0.098	0.083	0.071	0.062	0.042
Zero-sequence short-circuit reactance phase - N	X <sub>o</sub> [mΩ/m]	0.159	0.151	0.151	0.114	0.098	0.065	0.056	0.055	0.042	0.028
Zero-sequence short-circuit impedance phase - N	Z <sub>o</sub> [mΩ/m]	0.233	0.216	0.216	0.162	0.155	0.118	0.100	0.090	0.075	0.050
Zero-sequence short-circuit resistance phase - PE	R <sub>o</sub> [mΩ/m]	0.408	0.320	0.320	0.220	0.188	0.142	0.092	0.077	0.061	0.046
Zero-sequence short-circuit reactance phase - PE	X <sub>o</sub> [mΩ/m]	0.196	0.158	0.158	0.126	0.135	0.136	0.104	0.088	0.075	0.052
Zero-sequence short-circuit impedance phase - PE	Z <sub>o</sub> [mΩ/m]	0.453	0.357	0.357	0.254	0.231	0.197	0.139	0.117	0.097	0.069
Voltage drop with distributed load	$\Delta V$ [V/m/A] 10 <sup>-6</sup> cosφ = 0.70	39.9	31.5	33.0	25.6	22.1	17.1	12.2	10.5	8.9	**
	$\Delta V$ [V/m/A] 10 <sup>-6</sup> cosφ = 0.75	40.7	32.2	33.9	26.1	22.4	17.4	12.4	10.8	8.9	**
	$\Delta V$ [V/m/A] 10 <sup>-6</sup> cosφ = 0.80	41.3	32.8	34.6	26.5	22.6	17.5	12.6	10.9	9.0	**
	$\Delta V$ [V/m/A] 10 <sup>-6</sup> cosφ = 0.85	41.7	33.3	35.1	26.7	22.7	17.5	12.8	11.0	9.0	**
	$\Delta V$ [V/m/A] 10 <sup>-6</sup> cosφ = 0.90	41.7	33.4	35.4	26.7	22.5	17.4	12.8	11.0	8.9	**
	$\Delta V$ [V/m/A] 10 <sup>-6</sup> cosφ = 0.95	41.1	33.1	35.1	26.2	22.0	17.0	12.6	10.9	8.6	**
$\Delta V$ [V/m/A] 10 <sup>-6</sup> cosφ = 1.00	36.7	30.0	32.2	23.3	19.1	14.7	11.2	9.8	7.3	**	
Weight (PE 1)	p [kg/m]	39	39	39	53	58	86	105	126	158	210
Weight (PE 2)	p [kg/m]	41	41	41	55	60	83	111	134	174	235
Weight (PE 3)	p [kg/m]	38	38	38	52	57	79	104	126	163	218
Fire load	[kWh/m]	5.6	6.9	6.9	10.0	10.3	13.1	20.0	23.8	26.3	40
Degree of protection	IP	55	55	55	55	55	55	55	55	55	55
Insulation material thermal resistance class		B/F*	B/F*	B/F*	B/F*	B/F*	B/F*	B/F*	B/F*	B/F*	B/F*
Losses for the Joule effect at nominal current	P [W/m]	81	104	174	207	265	319	399	541	636	773
Ambient temperature min/MAX	[°C]	-5/50	-5/50	-5/50	-5/50	-5/50	-5/50	-5/50	-5/50	-5/50	-5/50

#### Regulations and conformity:

- IEC/EN 61439-6;
- Product suitable for Constant/Cyclic Warm, humid climates:**
  - EC 60068 2-11: Environmental tests Part 2-11: Tests – Test Ka: Salt mist
  - IEC 60068 2-30: Environmental tests Part 2-30: Tests – Test Db: Damp heat, cyclic (12 h + 12 h cycle)

#### Degree of protection:

IP55, on request IP65; IPx7 carrying lines available with accessories, on request

#### Insulation and surface treatment of the conductors:

Insulated conductors for the whole length, tin-plated aluminium conductors and copper without galvanic treatment

#### Busbar casing material:

1.5mm galvanized steel plate, pre-painted or stainless steel (available, if required, with special paint and/or with thickness 2 mm or with stainless steel casing)

#### Note:

**\*\* Class F thermal resistance (155°C) available on request**  
**\*\*6300A Cu – Only for transport of energy (for calculation of voltage drop, look at dedicated chapter "Choosing Guide")**



PE 1  
Standard version



PE 2  
Extra earth - COPPER  
SCP Cu 3L+N+50%PE  
(tinned copper conductors  
available on request)



PE 3  
Extra earth - ALUMINUM

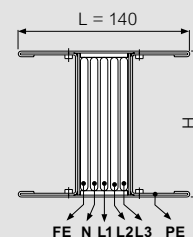

In: rated current referred to a room temperature of 40°C  
 $\Delta V$ : for calculations, see on chapter "Choosing Guide"

## SCP 2N AI - Double Neutral

Rated current	3P+2N+PE										
	In [A]	630	800	1000	1250	1600	2000	2500	3200	4000	5000**
Overall dimension of the busbars	L x H [mm]	140x130	140x130	140x130	140x130	140x170	140x220	140x380	140x440	140x480	
Operational voltage	Ue [V]	1000	1000	1000	1000	1000	1000	1000	1000	1000	1000
Insulation voltage	Ui [V]	1000	1000	1000	1000	1000	1000	1000	1000	1000	1000
Frequency	f [Hz]	50/60	50/60	50/60	50/60	50/60	50/60	50/60	50/60	50/60	50/61
Rated short-time current (1 s)	Icw [kA]rms	36	42	50	75	80	80	150	160	160	160
Peak current	Ipk [kA]	76	88	110	165	176	176	330	352	352	352
Rated short-time current of the neutral bar (1 s)	Icw [kA]rms	22	25	30	45	48	48	90	96	96	96
Peak current of the neutral bar	Ipk [kA]	48	55	66	99	106	106	198	211	211	211
Rated short-time current of the protective circuit (1 s)	Icw [kA]rms	22	25	30	45	48	48	90	96	96	96
Peak current of the protective circuit	Ipk [kA]	48	55	66	99	106	106	198	211	211	211
Phase resistance	R20 [mΩ/m]	0.077	0.057	0.057	0.046	0.033	0.025	0.021	0.016	0.013	0.011
Phase reactance (50 Hz)	X [mΩ/m]	0.023	0.017	0.017	0.015	0.014	0.011	0.006	0.006	0.006	0.003
Phase impedance	Z [mΩ/m]	0.080	0.059	0.059	0.048	0.036	0.027	0.022	0.017	0.014	0.011
Phase resistance at thermal conditions	Rt [mΩ/m]	0.084	0.063	0.068	0.055	0.039	0.030	0.024	0.019	0.016	0.012
Phase impedance at thermal conditions	Z [mΩ/m]	0.087	0.066	0.070	0.057	0.041	0.032	0.025	0.020	0.018	0.013
Neutral resistance	R20 [mΩ/m]	0.039	0.029	0.029	0.023	0.017	0.013	0.011	0.008	0.007	0.006
Resistance of the protective bar (PE type 2)	RPE [mΩ/m]	0.121	0.121	0.121	0.121	0.110	0.098	0.074	0.068	0.064	0.038
Resistance of the protective bar (PE type 2)	RPE [mΩ/m]	0.035	0.035	0.035	0.035	0.028	0.023	0.014	0.012	0.011	0.007
Resistance of the protective bar (PE type 3)	RPE [mΩ/m]	0.050	0.050	0.050	0.050	0.040	0.033	0.020	0.018	0.017	0.010
Reactance of the protective bar (50 Hz)	XPE [mΩ/m]	0.080	0.078	0.078	0.048	0.039	0.028	0.020	0.015	0.016	0.010
Resistance of the fault loop (PE 1)	Ro [mΩ/m]	0.205	0.184	0.189	0.176	0.149	0.128	0.098	0.087	0.080	0.050
Resistance of the fault loop (PE 2)	Ro [mΩ/m]	0.119	0.098	0.103	0.090	0.067	0.053	0.038	0.031	0.027	0.019
Resistance of the fault loop (PE 3)	Ro [mΩ/m]	0.134	0.113	0.118	0.105	0.079	0.063	0.044	0.037	0.033	0.022
Reactance of the fault loop (50 Hz)	Xo [mΩ/m]	0.10	0.10	0.10	0.06	0.05	0.04	0.03	0.02	0.02	0.01
Impedance of the fault loop (PE 1)	Zo [mΩ/m]	0.230	0.207	0.212	0.187	0.158	0.134	0.102	0.090	0.083	0.052
Impedance of the fault loop (PE 2)	Zo [mΩ/m]	0.158	0.137	0.140	0.110	0.085	0.066	0.046	0.038	0.035	0.023
Impedance of the fault loop (PE 3)	Zo [mΩ/m]	0.169	0.148	0.152	0.123	0.095	0.074	0.051	0.043	0.040	0.026
Zero-sequence short-circuit resistance phase - N	Ro [mΩ/m]	0.147	0.135	0.135	0.132	0.129	0.126	0.084	0.063	0.048	0.042
Zero-sequence short-circuit reactance phase - N	Xo [mΩ/m]	0.198	0.180	0.180	0.166	0.160	0.190	0.135	0.165	0.103	0.068
Zero-sequence short-circuit impedance phase - N	Zo [mΩ/m]	0.247	0.225	0.225	0.212	0.206	0.228	0.159	0.177	0.114	0.080
Zero-sequence short-circuit resistance phase - PE	Ro [mΩ/m]	0.581	0.519	0.519	0.369	0.321	0.270	0.217	0.196	0.164	0.109
Zero-sequence short-circuit reactance phase - PE	Xo [mΩ/m]	0.263	0.229	0.229	0.191	0.175	0.212	0.155	0.148	0.146	0.078
Zero-sequence short-circuit impedance phase - PE	Zo [mΩ/m]	0.638	0.567	0.567	0.416	0.366	0.343	0.267	0.246	0.220	0.133
Voltage drop with distributed load	$\Delta V$ [V/m/A]10 <sup>-6</sup> cosφ = 0.70	65.3	48.9	51.9	42.9	32.3	25.1	18.4	15.4	13.7	**
	$\Delta V$ [V/m/A]10 <sup>-6</sup> cosφ = 0.75	67.9	50.9	54.1	44.6	33.4	25.9	19.2	16.0	14.1	**
	$\Delta V$ [V/m/A]10 <sup>-6</sup> cosφ = 0.80	70.3	52.7	56.1	46.2	34.3	26.7	19.9	16.5	14.5	**
	$\Delta V$ [V/m/A]10 <sup>-6</sup> cosφ = 0.85	72.5	54.4	58.0	47.7	35.1	27.3	20.6	16.9	14.9	**
	$\Delta V$ [V/m/A]10 <sup>-6</sup> cosφ = 0.90	74.3	55.8	59.6	48.9	35.7	27.7	21.2	17.3	15.1	**
	$\Delta V$ [V/m/A]10 <sup>-6</sup> cosφ = 0.95	75.5	56.7	60.8	49.7	35.9	27.8	21.6	17.5	15.2	**
$\Delta V$ [V/m/A]10 <sup>-6</sup> cosφ = 1.00	72.9	54.9	59.1	48.0	33.8	26.2	21.0	16.7	14.3	**	
Weight (PE 1)	p [kg/m]	21.6	21.3	21.3	23.4	25.4	38.4	54.6	65.4	78.4	109.3
Weight (PE 2)	p [kg/m]	23.0	22.8	22.8	26.4	28.6	41.4	60.1	72.1	84.9	134.8
Weight (PE 3)	p [kg/m]	20.6	20.4	20.4	24.0	25.5	37.4	53.1	64.0	76.0	117.3
Fire load	[kWh/m]	5.6	6.9	6.9	7.5	10.6	13.1	20.0	23.8	26.3	40.0
Degree of protection	IP	55	55	55	55	55	55	55	55	55	55
Insulation material thermal resistance class		B/F*	B/F*	B/F*	B/F*	B/F*	B/F*	B/F*	B/F*	B/F*	B/F*
Losses for the Joule effect at nominal current	P [W/m]	100	122	205	260	300	363	455	592	790	935
Ambient temperature min/MAX	[°C]	-5/50	-5/50	-5/50	-5/50	-5/50	-5/50	-5/50	-5/50	-5/50	-5/50

### Regulations and conformity:

- IEC/EN 61439-6;
- Product suitable for Constant/Cyclic Warm, humid climates:
  - EC 60068 2-11: Environmental tests Part 2-11: Tests - Test Ka: Salt mist
  - IEC 60068 2-30: Environmental tests Part 2-30: Tests - Test Db: Damp heat, cyclic (12 h + 12 h cycle)

### Degree of protection:

- IP55, on request IP65; IPx7 carrying lines available with accessories, on request

### Insulation and surface treatment of the conductors:

- Insulated conductors for the whole length, tin-plated aluminium conductors and copper without galvanic treatment

### Busbar casing material:

- 1.5mm galvanized steel plate, pre-painted or stainless steel (available, if required, with special paint and/or with thickness 2 mm or with stainless steel casing)

### Note:

- \* Class F thermal resistance (155°C) available on request
- \*\*5000A AI - Only for transport of energy (for calculation of voltage drop, look at dedicated chapter "Choosing Guide")

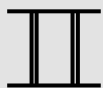

PE 1  
Standard version



PE 2  
Extra earth - COPPER



PE 3  
Extra earth - ALUMINUM  
SCP AI 3L+N+50%PE  
(available on request)

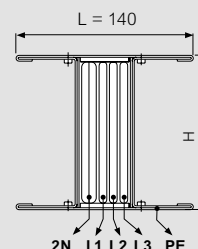

In: rated current referred to a room temperature of 40°C  
 $\Delta V$ : for calculations, see on chapter "Choosing Guide"

### SCP 2N CU - Double Neutral

Rated current	3P+2N+PE										
	In [A]	800	1000	1250	1600	2000	2500	3200	4000	5000	6300**
Overall dimension of the busbars	L x H [mm]	140x130	140x130	140x130	140x170	140x170	140x220	140x380	140x440	140x480	
Operational voltage	Ue [V]	1000	1000	1000	1000	1000	1000	1000	1000	1000	1000
Insulation voltage	Ui [V]	1000	1000	1000	1000	1000	1000	1000	1000	1000	1000
Frequency	f [Hz]	50/60	50/60	50/60	50/60	50/60	50/60	50/60	50/60	50/60	50/60
Rated short-time current (1 s)	Icw [kA]rms	45	50	60	85	88	88	170	176	176	176
Peak current	Ipk [kA]	95	110	132	187	194	194	374	387	387	387
Rated short-time current of the neutral bar (1 s)	Icw [kA]rms	27	30	36	51	53	53	102	106	106	106
Peak current of the neutral bar	Ipk [kA]	57	66	79	112	116	116	224	232	232	232
Rated short-time current of the protective circuit (1 s)	Icw [kA]rms	27	30	36	51	53	53	102	106	106	106
Peak current of the protective circuit	Ipk [kA]	57	66	79	112	116	116	224	232	232	232
Phase resistance	R20 [mΩ/m]	0.039	0.030	0.030	0.022	0.018	0.014	0.011	0.009	0.007	0.006
Phase reactance (50 Hz)	X [mΩ/m]	0.023	0.017	0.017	0.015	0.014	0.011	0.007	0.006	0.006	0.004
Phase impedance	Z [mΩ/m]	0.045	0.035	0.035	0.027	0.023	0.018	0.013	0.011	0.009	0.007
Phase resistance at thermal conditions	Rt [mΩ/m]	0.042	0.035	0.037	0.027	0.022	0.017	0.013	0.011	0.008	0.006
Phase impedance at thermal conditions	Z [mΩ/m]	0.048	0.039	0.041	0.031	0.026	0.020	0.015	0.013	0.010	0.007
Neutral resistance	R20 [mΩ/m]	0.020	0.015	0.015	0.011	0.009	0.007	0.006	0.005	0.003	0.003
Resistance of the protective bar (PE type 2)	RPE [mΩ/m]	0.125	0.125	0.125	0.113	0.113	0.101	0.075	0.069	0.065	0.038
Resistance of the protective bar (PE type 2)	RPE [mΩ/m]	0.036	0.036	0.036	0.028	0.028	0.023	0.014	0.012	0.011	0.007
Resistance of the protective bar (PE type 3)	RPE [mΩ/m]	0.050	0.050	0.050	0.041	0.041	0.033	0.021	0.018	0.017	0.011
Reactance of the protective bar (50 Hz)	XPE [mΩ/m]	0.054	0.054	0.054	0.044	0.044	0.032	0.022	0.017	0.016	0.011
Resistance of the fault loop (PE 1)	Ro [mΩ/m]	0.167	0.160	0.162	0.140	0.135	0.118	0.088	0.080	0.073	0.044
Resistance of the fault loop (PE 2)	Ro [mΩ/m]	0.078	0.071	0.073	0.055	0.050	0.040	0.027	0.023	0.019	0.013
Resistance of the fault loop (PE 3)	Ro [mΩ/m]	0.092	0.085	0.087	0.068	0.063	0.050	0.034	0.029	0.025	0.017
Reactance of the fault loop (50 Hz)	Xo [mΩ/m]	0.077	0.071	0.071	0.059	0.058	0.043	0.029	0.023	0.022	0.015
Impedance of the fault loop (PE 1)	Zo [mΩ/m]	0.184	0.175	0.177	0.152	0.147	0.126	0.093	0.083	0.077	0.046
Impedance of the fault loop (PE 2)	Zo [mΩ/m]	0.110	0.100	0.102	0.081	0.077	0.059	0.040	0.033	0.029	0.020
Impedance of the fault loop (PE 3)	Zo [mΩ/m]	0.120	0.110	0.112	0.090	0.086	0.066	0.045	0.037	0.034	0.022
Zero-sequence short-circuit resistance phase - N	Ro [mΩ/m]	0.128	0.125	0.125	0.121	0.117	0.094	0.088	0.065	0.046	0.044
Zero-sequence short-circuit reactance phase - N	Xo [mΩ/m]	0.184	0.152	0.152	0.143	0.127	0.122	0.078	0.076	0.073	0.039
Zero-sequence short-circuit impedance phase - N	Zo [mΩ/m]	0.224	0.197	0.197	0.187	0.173	0.154	0.118	0.100	0.086	0.059
Zero-sequence short-circuit resistance phase - PE	Ro [mΩ/m]	0.507	0.429	0.429	0.331	0.283	0.221	0.177	0.178	0.144	0.089
Zero-sequence short-circuit reactance phase - PE	Xo [mΩ/m]	0.201	0.177	0.177	0.143	0.150	0.124	0.111	0.094	0.086	0.056
Zero-sequence short-circuit impedance phase - PE	Zo [mΩ/m]	0.545	0.464	0.464	0.361	0.320	0.253	0.209	0.201	0.168	0.104
Voltage drop with distributed load	$\Delta V$ [V/m/A] $10^{-6} \cos\varphi = 0.70$	39.9	31.5	33.0	25.6	22.1	17.1	12.2	10.5	8.9	**
	$\Delta V$ [V/m/A] $10^{-6} \cos\varphi = 0.75$	40.7	32.2	33.9	26.1	22.4	17.4	12.4	10.8	8.9	**
	$\Delta V$ [V/m/A] $10^{-6} \cos\varphi = 0.80$	41.3	32.8	34.6	26.5	22.6	17.5	12.6	10.9	9.0	**
	$\Delta V$ [V/m/A] $10^{-6} \cos\varphi = 0.85$	41.7	33.3	35.1	26.7	22.7	17.5	12.8	11.0	9.0	**
	$\Delta V$ [V/m/A] $10^{-6} \cos\varphi = 0.90$	41.7	33.4	35.4	26.7	22.5	17.4	12.8	11.0	8.9	**
	$\Delta V$ [V/m/A] $10^{-6} \cos\varphi = 0.95$	41.1	33.1	35.1	26.2	22.0	17.0	12.6	10.9	8.6	**
$\Delta V$ [V/m/A] $10^{-6} \cos\varphi = 1.00$	36.7	30.0	32.2	23.3	19.1	14.7	11.2	9.8	7.3	**	
Weight (PE 1)	p [kg/m]	39	39	39	53	58	86	105	126	158	210
Weight (PE 2)	p [kg/m]	41	41	41	55	60	83	111	134	174	235
Weight (PE 3)	p [kg/m]	38	38	38	52	57	79	104	126	163	218
Fire load	[kWh/m]	5.6	6.9	6.9	10.0	10.3	13.1	20.0	23.8	26.3	40
Degree of protection	IP	55	55	55	55	55	55	55	55	55	55
Insulation material thermal resistance class		B/F*	B/F*	B/F*	B/F*	B/F*	B/F*	B/F*	B/F*	B/F*	B/F*
Losses for the Joule effect at nominal current	P [W/m]	81	104	174	207	265	319	399	541	636	773
Ambient temperature min/MAX	[°C]	-5/50	-5/50	-5/50	-5/50	-5/50	-5/50	-5/50	-5/50	-5/50	-5/50

**- Regulations and conformity:**

- IEC/EN 61439-6;
- Product suitable for Constant/Cyclic Warm, humid climates:**
  - EC 60068 2-11: Environmental tests Part 2-11: Tests – Test Ka: Salt mist
  - IEC 60068 2-30: Environmental tests Part 2-30: Tests – Test Db: Damp heat, cyclic (12 h + 12 h cycle)

**- Degree of protection:**

IP55, on request IP65; IPx7 carrying lines available with accessories, on request

**- Insulation and surface treatment of the conductors:**

Insulated conductors for the whole length, tin-plated aluminium conductors and copper without galvanic treatment

**- Busbar casing material:**

1.5mm galvanized steel plate, pre-painted or stainless steel (available, if required, with special paint and/or with thickness 2 mm or with stainless steel casing)

**Note:**

\* Class F thermal resistance (155°C) available on request  
 \*\*6300A Cu – Only for transport of energy (for calculation of voltage drop, look at dedicated chapter "Choosing Guide")



PE 1 Standard version



PE 2 Extra earth - COPPER SCP Cu 3L+N+50%PE (tinned copper conductors available on request)



PE 3 Extra earth - ALUMINUM

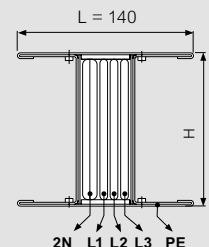

In: rated current referred to a room temperature of 40°C  
 $\Delta V$ : for calculations, see on chapter "Choosing Guide"

## Super compact (SCP)

### measurement of special element lengths

#### Measurement of straight elements

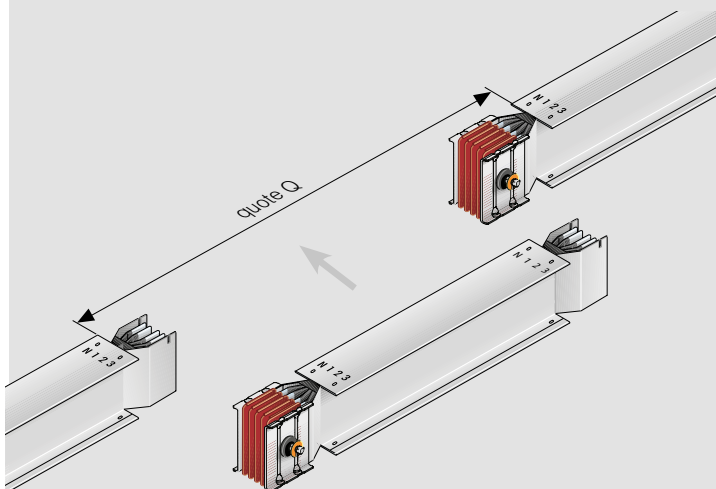

The exact length of the piece to be ordered can be determined by measuring the distance between the elements (as shown in the picture) and then subtracting 270 mm from the dimension that has been taken

$$\text{Length of element} = Q - 270 \text{ mm}$$

Example: Dimension measured  $Q = 2500 \text{ mm}$   
Order a element  $(2500 - 270) = 2230 \text{ mm}$

#### Measurement of the size for the ordering of a special path element

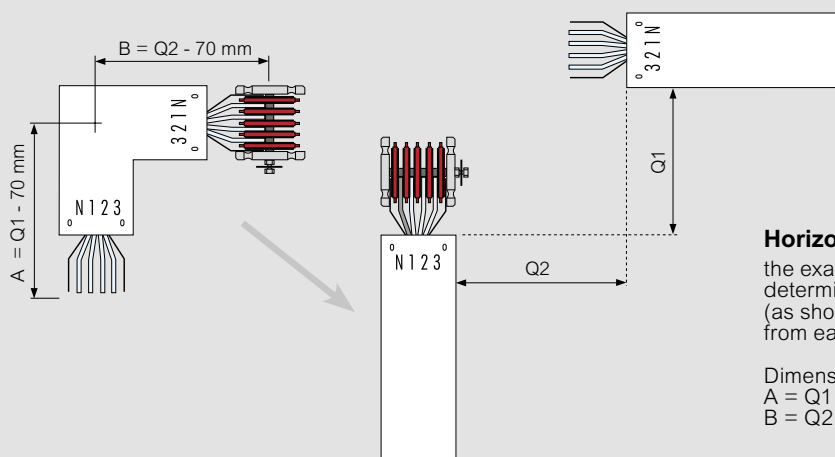

#### Horizontal elbow

the exact length of the piece to be ordered can be determined by measuring the dimensions  $Q1$  and  $Q2$  (as shown in the picture) and then subtracting 70 mm from each dimension that has been taken

Dimension of the element to order:  
 $A = Q1 - 70 \text{ mm}$   
 $B = Q2 - 70 \text{ mm}$



# Super compact (SCP)

## installation guidelines

### Installation sequence of the junction

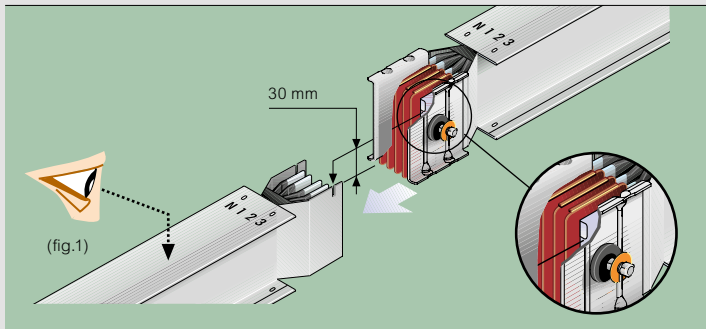

The installation instructions are placed on every element near the junction

Make sure that the contacts are clean

Join the two elements together (Fig.1)

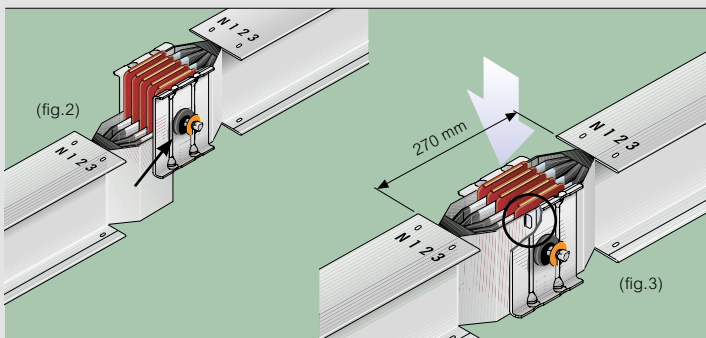

Make sure that the earth plate of the straight element is inserted behind the front plate of the junction monobloc (Fig.2)

The positioning pin on the monobloc should be fitted into the corresponding slot on the earth plate

Verify the distance between elements, 270mm, before tightening the monobloc completely (Fig.3)

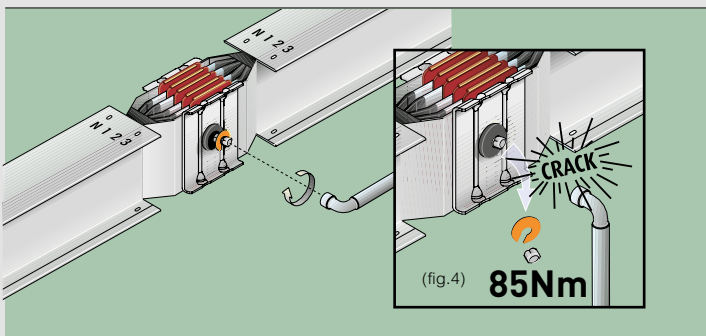

Tighten the bolt of the monobloc until the 1st head breaks off (Fig. 4).

The bolt that tightens the monobloc has a second head which is used when carrying out operations or inspections on the line

The nominal tightening torque is 85Nm

**In standard execution the self-shearing bolt is fitted on the opposite side of the Neutral.**

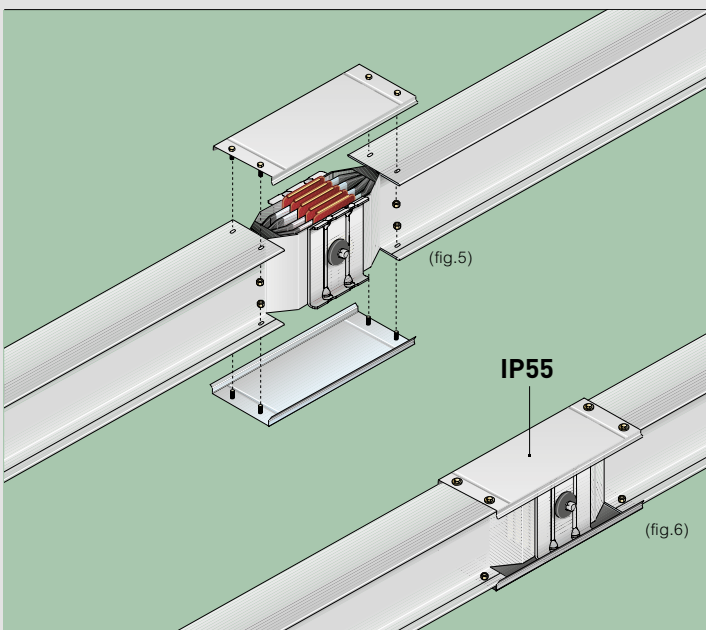
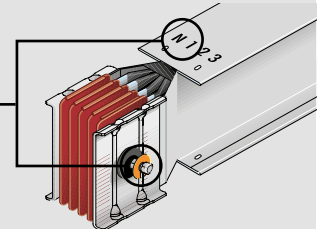

Install the covers of the junction (fig. 5)

Connection completed correctly with Protection degree IP55 (fig.6)

# Super compact (SCP)

## mechanical design precautions

Below are some precautions that may be useful to avoid problems during the assembly, which we recommend should be taken into account during the design

### Minimum distances from the structure

The minimum distance from the walls, to avoid problems during edgewise installation of the busbar, is 300 mm  
The variables that must be taken into account for correct assembly are:

- position of the bolt for tightening the Monobloc; the minimum required distance is 100 mm;
- sizes of the distribution element (box) selected for the collection of power (at least 300 mm);
- any brackets and their assembly;
- accessibility to the screws for the installation of the brackets and the closing of the junctions;
- any material required for the actual installation in order to compensate for wall imperfections

In case of rising mains installation, if the system does not require fire barriers, the bracket supporting the bracket can be directly secured to the wall. Otherwise, allow for a spacing support between the bracket and the wall, to ensure that the back of the busbar remains at a distance of 100 mm from the wall, therefore ensuring enough space for the positioning of the partitions

### Minimum distance of the wall / ceiling elements

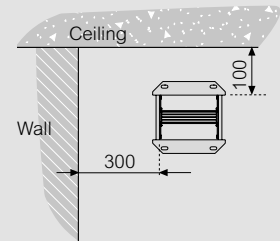
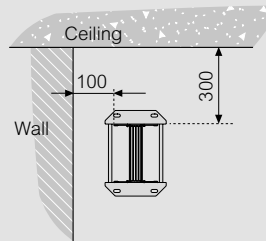
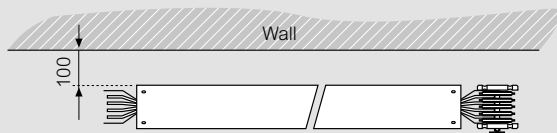

When there are tap-off units along the busbars, the minimum distances depend on the dimensions of the tap-offs selected

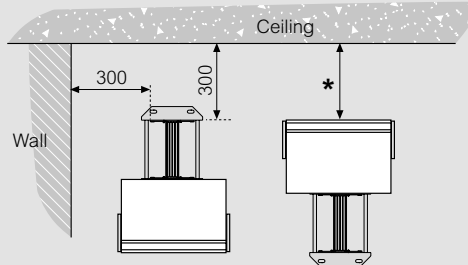
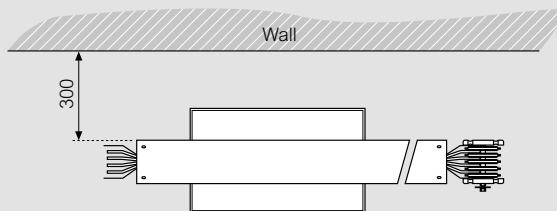

\* When there is a tap-off box installed above the busbar, check the overall dimension of the open cover of the tap-off unit used in the specific section

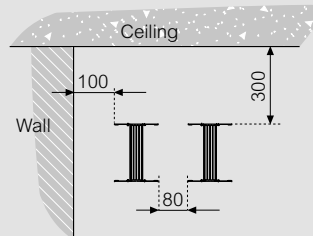
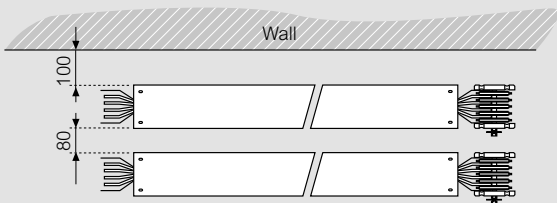

Minimum installation distance when there are several adjacent lines

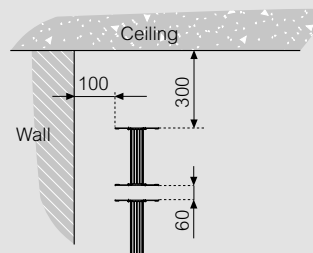
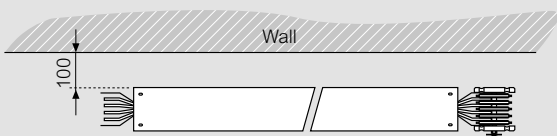

Minimum installation distance when there are several overlapped lines

The minimum distance from the junction to the point the busbar crosses the wall or other structure must be at least 200 mm, to ensure the junction of the junctions

In case plug-in boxes and fire barriers are required on the same element the minimum distance between the box and the partition must be taken into account, at the same time allowing for the necessary free space in the junction area and the minimum distance between the distribution outlet and the start of the element

By taking all these variables into account, it is possible to obtain the minimum size of the element in order to be able to fit the partition and the plug-in box. The tables that follow summarise the minimum sizes

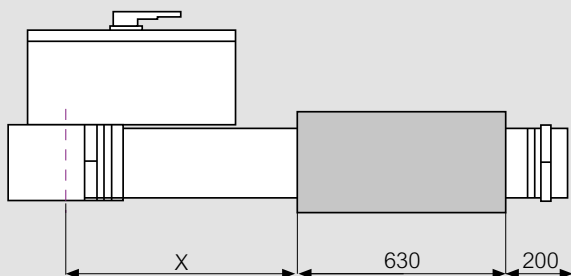
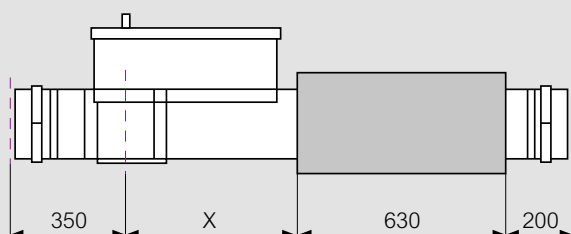
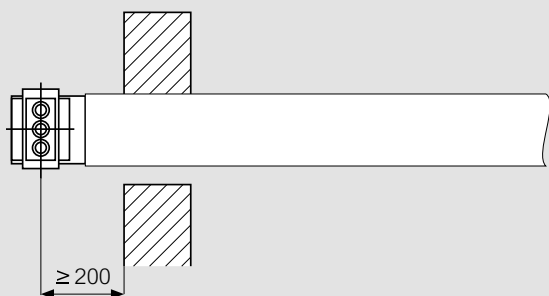

Referred to Aluminium

PLUG-IN TAP OF BOXES (X MINIMUM SIZE)		
Type	Rating (A)	X (mm)
1	63 – 160	520
2	250 – 630	720
3	125 – 400	620

Referred to Aluminium

PLUG-IN BOXES ON THE JUNCTION		
Type	Rating (A)	X (mm)
4/5	125 – 400	700
4/5	630	820
4/5	800 – 1250	1120

### ■ Connection to the board

As a rule, the manufacturer of the board is responsible for connecting the connection element and the distribution busbars inside the board

On request Legrand may develop and supply the connections, subject to all necessary details being available

All types of connections must be agreed and checked with the board manufacturer

### ■ Short circuit withstand

The short circuit withstand of the connection elements depends on the connection of the busbars inside the distribution board

The declaration of short circuit withstand for the system busbars may only be supplied by the board manufacturer. When using Legrand boards and Legrand busbar trunking system it will be possible to obtain a short circuit certification

# Super compact (SCP)

## technical informations

### Table of comparison between boxes and cable glands (Legrand)

The following table shows the maximum number of Legrand cable glands that can be installed on Plug-in boxes using the appropriate flanges

COMPARISON TABLE BETWEEN Plug-in boxes AND CABLE GLANDS (LEGRAND)						
	Useful dimension for the passage of the cables and flange size	M16-PG9 (63 A cable) 10 mm <sup>2</sup> section PVC insulated one-pole cable	M20-PG13.5 (63 A cable) 10 mm <sup>2</sup> section PVC insulated one-pole cable	M25-PG21 (250 A cable) 70 mm <sup>2</sup> section PVC insulated one-pole cable	M32-PG29 (400 A cable) 150 mm <sup>2</sup> section PVC insulated one-pole cable	M40-PG36 (630 A cable) 300 mm <sup>2</sup> section PVC insulated one-pole cable
63/160 A Plug-in box with section cover (Type 1/3)	80 x 70 FL 110 x 100	No. 10	No. 5	—	—	—
250/630 A Plug-in box with section cover (Type 2)	150 x 220 FL 235x 180	No. 66	No. 36	No. 20	No. 13	No. 8
125/400 A Plug-in box on the junction (Type 4/5)	130 x 180 FL 180 x 230	—	No. 30	No. 16	No. 9	—
630 A Plug-in box on the junction (Type 4/5)	270 x 160 FL 340 x 230	—	—	No. 28	No. 15	No. 10
800/1250 A Plug-in box on the junction (Type 4/5)	380 x 210 FL 430 x 260	—	—	No. 57	No. 32	No. 18

**Note:** The value shown on the table is the max no. of PG that may be installed in the cable flange  
For boxes with section cover the most demanding condition is considered, which means that only one of the two cable flanges is used

### Cable glands table

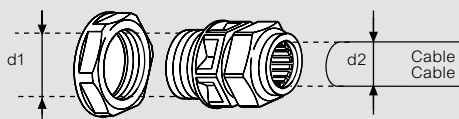

When choosing the cable glands, please refer to the LEGRAND catalogue

Dimension d2 Ø cable [mm]

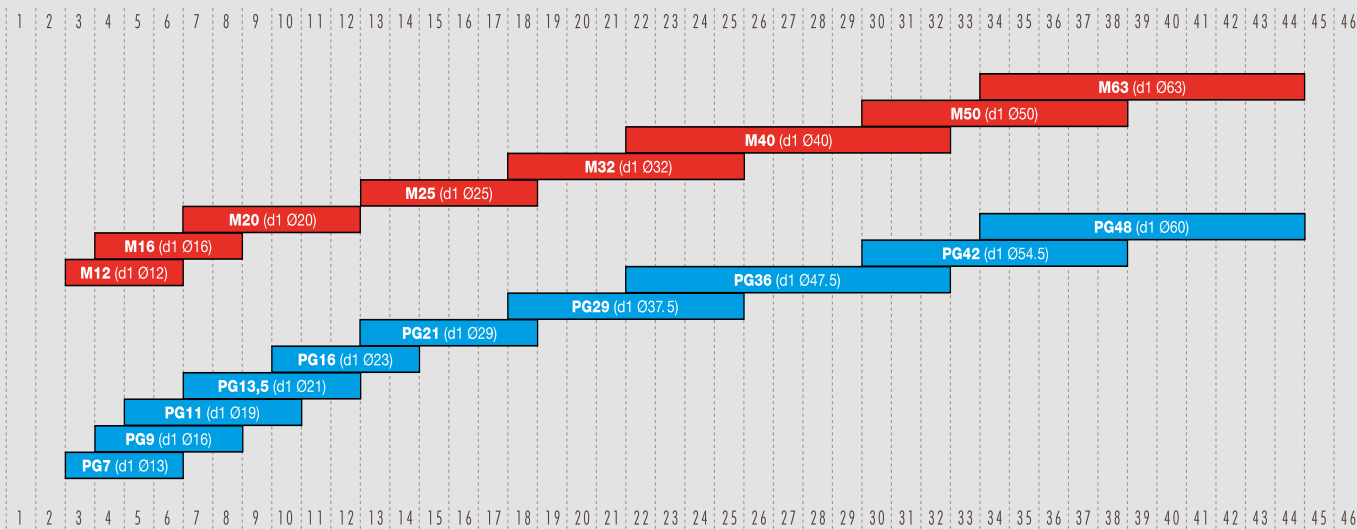

Dimension d2 Ø cable [mm]

### Ceramic fuse 5 x 20

#### Operating features

<b>I<sub>n</sub> = 6.3</b>	<b>1.5 I<sub>n</sub></b>	<b>2.1 I<sub>n</sub></b>	<b>2.75 I<sub>n</sub></b>	<b>4 I<sub>n</sub></b>	<b>10 I<sub>n</sub></b>
<b>Operating time &gt; 1 h</b>	<b>&lt; 30 min</b>	<b>10 ms - 3 s</b>	<b>3 ms - 30 ms</b>	<b>&lt; 20 ms</b>	

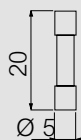

#### Quick fuse

- I<sub>n</sub> = 6.3A
- U<sub>e</sub> = 250V ceramic fuse IEC 127
- Breaking capacity H 1500A
- Voltage drop ΔV = 150 mV
- I<sup>2</sup>t = 48A<sup>2</sup>s

When choosing all fuses, please refer to the general Legrand catalogue

# CHOOSING GUIDE



## SECTION CONTENT

- 146 Joule Effect Losses in Busbar
- 147 Overload Protection
- 148 Selection of the Busbar Trunking System Based on Voltage Drop
- 149 Short Circuit Withstand
- 151 Harmonics
- 152 IP and IK Degree of Protections

## Joule effect losses in busbars

### ■ Technical informations

Losses due to the Joule effect are essentially caused by the electrical resistance of the busbar  
 Lost energy is transformed into heat and contributes to the heating of the conduit of the environment  
 The calculation of power loss is a useful data for correct sizing of the building air conditioning system

Three-phase regime losses are:

$$P_j = \frac{3 \cdot R_t \cdot I_b^2 \cdot L}{1000}$$

In one-phase regime:

$$P_j = \frac{2 \cdot R_t \cdot I_b^2 \cdot L}{1000}$$

Where:

- $I_b$  = Utilisation current (A)
- $R_t$  = Phase resistance for unit of length of the busbar trunking system, measured at thermal regime (mΩ/m)
- $L$  = Busbar length (m)

For accurate calculation, losses must be assessed trunk by trunk taking into account the transiting currents; for example, in the case of the distribution of the loads represented in the figure one has:

	Length	Transiting current	Losses
1st trunk	L1	$I_1+I_2+I_3$	$P_1 = 3R_t L_1 (I_1+I_2+I_3)^2$
2nd trunk	$L_2-L_1$	$I_2+I_3$	$P_2 = 3R_t (L_2-L_1) (I_2+I_3)^2$
3rd trunk	$L_3-L_2$	$I_3$	$P_3 = 3R_t (L_3-L_2) (I_3)^2$

Total losses in the busbar trunking system  $P_t = P_1+P_2+P_3$

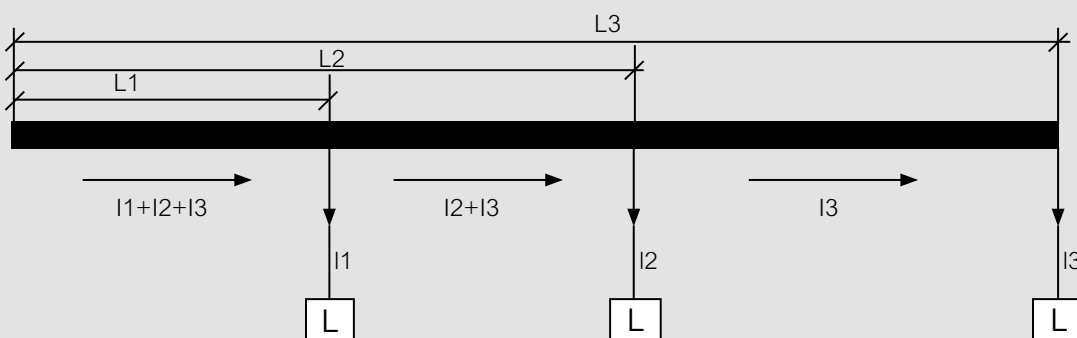

### ■ Losses based on the installation method

Thermal dispersion, rating and IP protection degree are independent from the type of installation (edgewise, flat, vertical)

This means that it is possible to install the SCP busbar trunking system as preferred, without having to consider a possible system downgrading

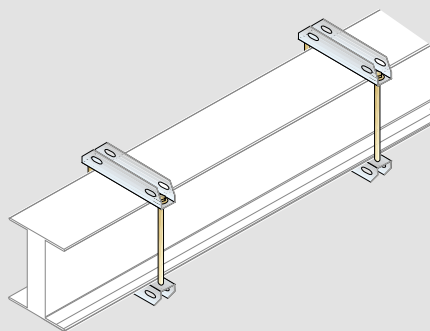

Edgewise element

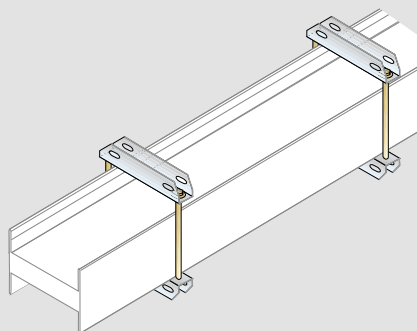

Flat element

# Overload protection

## Technical informations

Busbar overload protection is ensured following the same criteria used for cables. It will be necessary to check the relationship:

$$I_b \leq I_n \leq I_z$$

Where:

- $I_b$  = Circuit utilisation current
- $I_n$  = Switch rated current
- $I_z$  = Rating at permanent cable regime

The  $I_b$  utilisation current in a three-phase system is calculated based on the following formula:

$$I_b = \frac{P_t \cdot \alpha \cdot \beta \cdot d}{\sqrt{3} \cdot U_e \cdot \cos \varphi_{\text{medium}}} \text{ [A]}$$

Where:

- $P_t$  = Sum of the active powers of the loads installed [W]
- $d$  = Power supply factor equal to:  
1 if the trunking is only powered from one side;  
0,5 if the trunking is powered from the centre or from both ends at the same time
- $U_e$  = Operating voltage in [V]
- $\cos m$  = Average power factor of the loads
- $I_b$  = Operating current [A]
- $\alpha$  = Diversity coefficient of the loads [.]
- $\beta$  = Coefficient of utilisation of the loads [.]

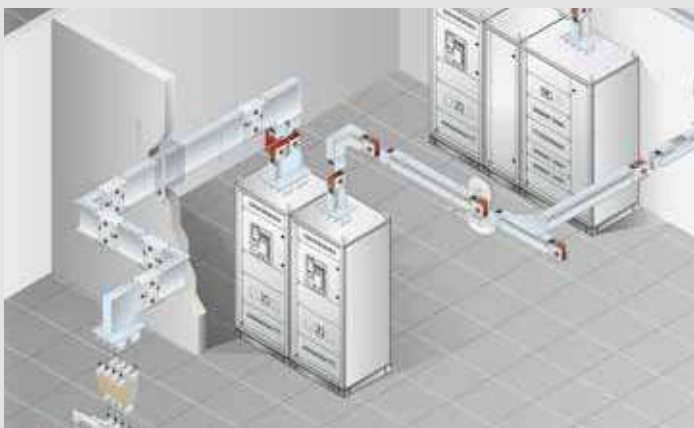
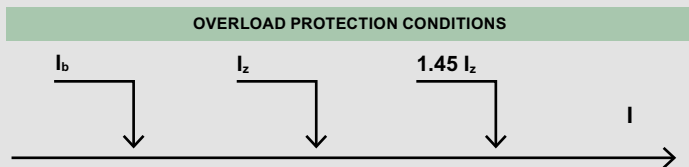

The ambient temperature where the busbar trunking system is installed impacts on its rating

During the design stages, it will be necessary to multiply the rating value at the reference temperature by a correction coefficient referred to the final operating temperature

All Legrand products have been sized and tested for an average ambient temperature of 40 °C. For installation in environments with average daily temperatures lower than 40 °C, the rated current of the busbar must be multiplied by a  $k_1$  factor, which is higher than the unit for temperatures lower than 40 °C, and lower than the unit if the ambient temperature is higher than 40 °C:

$$I_z = I_{z0} \cdot Kt$$

Where:

- $I_{z0}$  is the current that the busbar trunking system can carry for an indefinite time at its reference temperature (40 °C)
- $Kt$  is the correction coefficient for ambient temperature values other than the reference temperature, as shown in the following table

KT CORRECTION COEFFICIENT FOR AMBIENT TEMPERATURE OTHER THAN 40 °C										
Ambient temperature [°C]	15	20	25	30	35	40	45	50	55	60
$k_t$ thermal correction factor [.]	1.15	1.12	1.08	1.05	1.025	1	0.975	0.95	0.93	0.89

# Selection of the busbar trunking system based on voltage drop

## Technical informations

If the line is particularly long (> 100 m), it will be necessary to check the value of the voltage drop. For systems with power factor ( $\cos\varphi_m$ ) not lower than 0.8 the voltage loss can be calculated using the following formulas:

### THREE PHASE SYSTEM

$$\Delta v = \frac{b \cdot \sqrt{3} \cdot I_b \cdot L \cdot (R_t \cdot \cos\varphi_m + x \cdot \sin\varphi_m)}{1000}$$

### ONE-PHASE SYSTEMS

$$\Delta v = \frac{b \cdot 2 \cdot I_b \cdot L \cdot (R_t \cdot \cos\varphi_m + x \cdot \sin\varphi_m)}{1000}$$

The percentage voltage drop can be obtained from:

$$\Delta v\% = \frac{\Delta v}{V_r} \cdot 100$$

Where  $V_r$  is the system rated voltage

In order to limit the voltage drop in case of very long busbar trunking systems, it is possible to allow for a power supply at an intermediate position, rather than at the terminal point

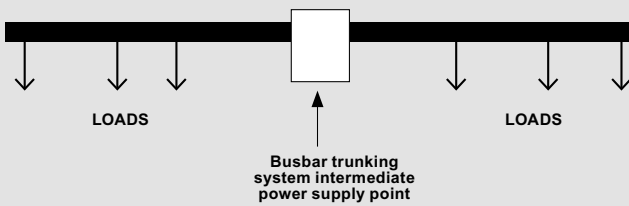

## Calculation of the voltage drop with loads not evenly distributed

In case the load cannot be considered evenly distributed, the voltage drop may be determined more accurately using the relationships shown below. For the distribution of three-phase loads, the voltage drop can be calculated using the following formula, on the assumption (generally verified) that the section of the busbar trunking system is consistent:

$$\Delta v = \sqrt{3} [R_t (I_{1L1} \cos\varphi_1 + I_{2L2} \cos\varphi_2 + I_{3L3} \cos\varphi_3) + x (I_{1L1} \sin\varphi_1 + I_{2L2} \sin\varphi_2 + I_{3L3} \sin\varphi_3)]$$

In general terms this becomes:

$$\Delta v = \frac{\sqrt{3} (R_t \sum I_i \cdot L_i \cdot \cos\varphi_{mi} + x \sum I_i \cdot L_i \cdot \sin\varphi_{mi})}{1.000}$$

If the three-phase system and the power factor are not lower than  $\cos\varphi = 0.7$ , the voltage loss may be calculated using the voltage drop coefficient shown in Table 1

$$\Delta v\% = 2b \cdot \frac{k \cdot I_b \cdot L}{V_n} \cdot 100$$

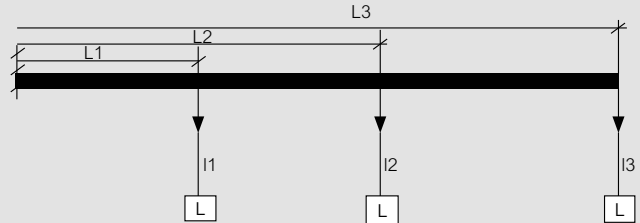

The current distribution factor "b" depends on how the circuit is fed and on the distribution of the electric loads along the busbar:

Table 1 - The distribution factor of the current "b"

<b>b = 1</b>	Supplies at one end and load at the end of the line	
<b>b = 1/2</b>	Supplies at one end and with load evenly distributed	
<b>b = 1/4</b>	Supplies at both ends and with load evenly distributed	
<b>b = 1/4</b>	Central supply with loads at both ends	
<b>b = 1/8</b>	Central supply with load distributed evenly	

Example: SCP 2000A AI for riser mains feed

$I_b$  = 1600A operating current  
 $b$  = 1/2 load evenly distributed  
 $k$  = 27.3 see technical data table (SCP 2000 A AI  $\cos\varphi = 0.85$ )  
 $\cos\varphi$  = 0.85  
 $L$  = 100 m line length  
 $V_n$  = 400 V operating voltage

$$\Delta v\% = \frac{27.3 \cdot 10^6 \cdot 1600 \cdot 100}{400} \cdot 100 = 1.09\%$$

### Legend:

$I_b$  = the current that supplies the busbar [A]  
 $V_n$  = the voltage power supply of the busbar [V]  
 $L$  = the length of the busbar [m]  
 $\Delta v\%$  = the voltage drop percentage  
 $b$  = the distribution factor of the current  
 $k$  = corresponding voltage drop factor a  $\cos\varphi$  [V/m/A] (see technical data table)  
 $\cos\varphi_m$  = Average power factor of the loads  
 $x$  = phase reactance by unit of length of the busbar (mΩ/m)  
 $R_t$  = phase resistance by unit of length of the busbar (mΩ/m)  
 $\cos\varphi_{mi}$  = i-th load average power factor  
 $I_i$  = i-th load current (A)  
 $L_i$  = distance of the i-th load from the origin of the busbar trunking system

# Short circuit withstand

## ■ Technical informations

The CEI 64-8 standard indicates that, for the protection of the circuits of the system, it is necessary to allow for devices aimed at interrupting short circuit currents before these become dangerous due to the thermal and mechanical effects generated in the conductors and the connections. In order to size the electric system and the protection devices correctly, it is necessary to know the value of the estimated short circuit current at the point where this is to be created. This value enables in fact to correctly select protection devices based on their own tripping and closing powers, and to check the resistance to electro-dynamic stress of the busbar supports installed in control panels, or/and of the busbar trunking systems.

## ■ Characterisation of short circuit current

The estimated short circuit current at a point of the user system is the current that would occur if in the considered point a connection of negligible resistance was created between conductors under voltage. The magnitude of this current is an estimated value that represents the worst possible condition (null fault impedance, tripping time long enough to enable the current to reach the maximum theoretical values). In reality, the short circuit always occurs with significantly lower effective current values.

The intensity of the estimated short circuit current essentially depends on the following factors:

- Power of the cabin Transformer, meaning that the higher is the power, the higher is the current;
- length of the line upstream

In three-phase circuits with Neutral it is possible to have three different types of short circuit:

- phase-phase;
- phase-Neutral;
- balanced three-phase (most demanding condition)

The formula for the calculation of the symmetric component is:

$$\overline{I_{cc}} = \frac{\overline{E}}{Z\overline{E} + Z\overline{L}}$$

Where:

- **E** is the phase voltage;
- **ZE** is the secondary equivalent impedance of the TRANSFORMER measured between the phase and the Neutral;
- **ZL** is the impedance of the phase conductor only

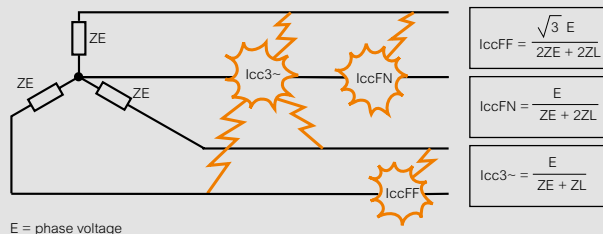
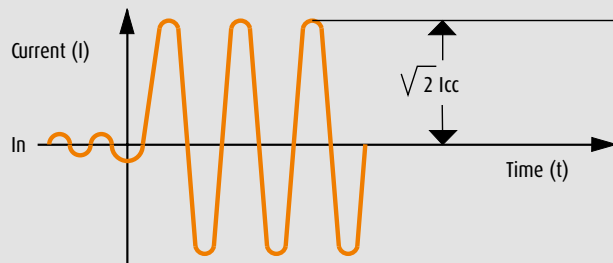
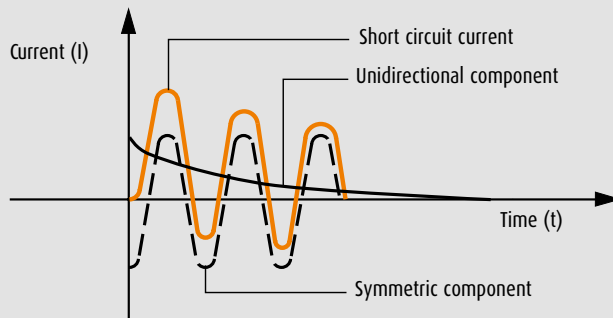

## Short circuit withstand (continued)

### Analytical determination of short circuit currents

In order to calculate the value of the estimated short circuit current at any point of the circuit, it is sufficient to apply the formulas shown below, knowing the impedance calculated at the origin of the system up to the point being assessed

In the formulas shown below, the value of the short circuit power is considered infinite and the short circuit impedance is equal to 0.

This makes it possible to define short circuit current values higher than the actual ones, but generally acceptable

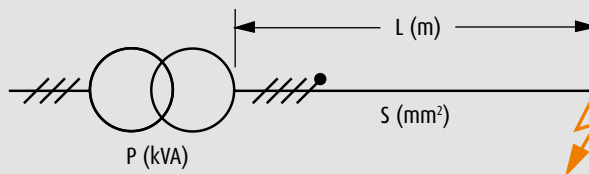

Line resistance $RL = r \cdot L$	<b>RL</b> = resistance of the line upstream (m) <b>r</b> = specific line resistance (m/m) <b>L</b> = upstream line length (m)
Line reactance $XL = x \cdot L$	<b>XL</b> = upstream line reactance (m) <b>x</b> = specific line reactance (m/m)
TRANSFORMER resistance $RE = \frac{1000 P_{cu}}{3I_n^2}$	<b>RE</b> = transformer secondary equivalent resistance (m) <b>P<sub>cu</sub></b> = transformer COPPER losses (W) <b>I<sub>n</sub></b> = transformer Rated current (A)
TRANSFORMER impedance $ZE = \frac{V_{cc}\% V^2c}{100 P}$	<b>ZE</b> = transformer secondary equivalent impedance (m) <b>V<sub>c</sub></b> = phase voltage (V) <b>V<sub>cc</sub>%</b> = percentage short circuit voltage <b>P</b> = transformer power (kVA)
TRANSFORMER reactance $XE = \sqrt{ZE^2 - RE^2}$	<b>XE</b> = transformer secondary equivalent reactance (m)
Short circuit impedance $Z_{cc} = \sqrt{(RL + RE)^2 + (XL + XE)^2}$	<b>Z<sub>cc</sub></b> = total short circuit impedance (m)
Estimated short circuit current $I_{cc} = \frac{V_{cc}}{\sqrt{3} \cdot Z_{cc}}$	<b>I<sub>cc</sub></b> = symmetric component of the short circuit current (kA)

ALUMINIUM				
Rating (A)	I <sub>cw</sub> (kA) three-phase	I <sub>pk</sub> (kA) three-phase	I <sub>cw</sub> (kA) one-phase	I <sub>pk</sub> (kA) one-phase
630	36	76	22	48
800	42	88	25	55
1000	50	110	30	66
1250	75	165	45	99
1600	80	176	48	106
2000	80	176	48	106
2500	150	330	90	198
3200	160	352	96	211
4000	160	352	96	211

COPPER				
Rating (A)	I <sub>cw</sub> (kA) three-phase	I <sub>pk</sub> (kA) three-phase	I <sub>cw</sub> (kA) one-phase	I <sub>pk</sub> (kA) one-phase
800	45	95	27	57
1000	50	110	30	66
1250	60	132	36	79
1600	85	187	51	112
2000	88	194	53	116
2500	88	194	53	116
3200	170	374	102	224
4000	176	387	106	232
5000	176	387	106	232

# Harmonics

## Technical informations

In a distribution system, currents and voltages should have a perfectly sinusoidal shape. However, in practice the equipment contains electric devices such as changeover devices or dimmers that make the load not linear

The currents absorbed, although at regular intervals and with frequencies equal to that of the rated voltage, sometime have a non-sinusoidal wave form, which has the following negative effects:

- worsening of the power factor;
- heating of the Neutral;
- additional losses in electric machinery (transformers and motors);
- instable operation of the protection elements (thermal magnetic and earth leakage circuit breakers)

In industrial plants these conditions have been occurring for a long time, However, they are now occurring more and more in service sector distribution systems, where, from backbone distribution (which uses three-phase lines), one-phase loads are often distributed, which contributes to increasing the unbalance of the electric system

Each type of non-sinusoidal periodical wave may be split into a more or less large number of sinusoids (called harmonic components), which frequency a whole multiple of the frequency of the wave shape observed

A deformed current at a frequency of 50 Hz, like for example that represented by the red line on the figure, consists of many sinusoidal currents with frequency of 50 Hz (fundamental), 100 Hz (second harmonic components), 150 Hz (third harmonics), and so on

The presence of current harmonics represents an important problem, causing overload conditions both on phase conductors, and on any Neutral conductor, and results in the reduction of the conductor permitted load

## Choice of the rating when in the presence of harmonics

When in the presence of harmonics, and when using the chosen Int rated current, the SCP busbar to be used shall have the rating specified in the table by side

Rated current	630 A	800 A	1000 A	1250 A	1600 A	2000 A	2500 A	3200 A	4000 A	5000 A
SCP busbar to be used:										
THD ≤ 15%	630 A	800 A	1000 A	1250 A	1600 A	2000 A	2500 A	3200 A	4000 A	5000 A
15% < THD ≤ 33%	800 A	1000 A	1250 A	1600 A	2000 A	2500 A	3200 A	4000 A	5000 A	—
THD > 33%	1000 A	1250 A	1600 A	2000 A	2500 A	3200 A	4000 A	5000 A	—	—

Measurement of harmonic distortion carried out with a network analyser

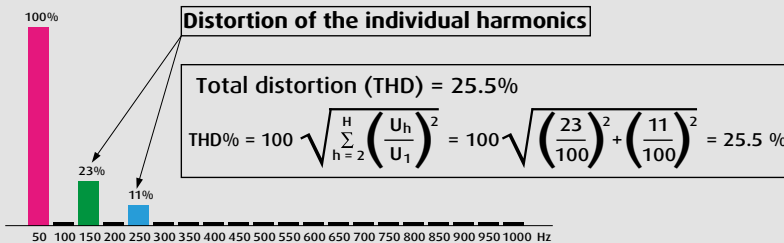
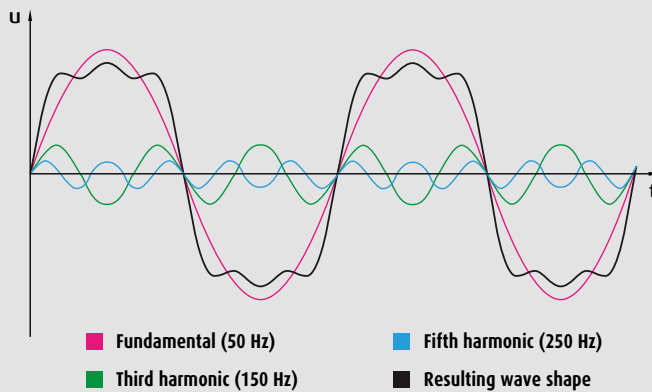

## Degrees of protection

### IP: degree of protection provided against intrusion

#### IP

The protection enclosures are classified (IEC 60529) in according to their degree of protection against weather conditions and external agents. The degree of protection is indicated by two digits (protection against solid bodies and liquids) following the symbol IP

To increase the ease of choice of the most suitable busbar, in according to installation requirements, below there is a summary of their performance, based on the IP degree of protection according to the IEC 60529 standard

#### 1<sup>st</sup> digit IP

##### Protection against penetration of solid bodies

	<b>0</b>	No protection
	<b>1</b>	Protection against solid bodies larger than 50 mm (e.g.: accidental contact)
	<b>2</b>	Protection against solid bodies larger than 12 mm (e.g.: finger)
	<b>3</b>	Protection against solid bodies larger than 2.5 mm
	<b>4</b>	Protection against solid bodies than 1 mm
	<b>5</b>	Protection against dust
	<b>6</b>	Complete protection against dust

#### 2<sup>nd</sup> digit IP

##### Protection against penetration of liquids

	<b>0</b>	No protection
	<b>1</b>	Protection against vertically-falling drops of water (condensation)
	<b>2</b>	Protection against drops of water falling up to 15° from the vertical
	<b>3</b>	Protection against drops of water up to 60° from the vertical
	<b>4</b>	Protection against sprays of water from all directions
	<b>5</b>	Protection against jets of water from all directions
	<b>6</b>	Protection against jets of water (similar force to heavy seas)
	<b>7</b>	Protection against the effects of immersion
	<b>8</b>	Protection against effects of immersion under pressure

## Degrees of protection

### IK: degree of protection of equipment to mechanical impact

#### IK

Standard IEC 62262 defines an IK code that characterises the aptitude of equipment to resist mechanical impacts on all sides

IK	Test	Impact energy (In joules)
IK 00		0
IK 01		0.15
IK 02		0.2
IK 03		0.35
IK 04		0.5
IK 05		0.7
IK 06		1
IK 07		2
IK 08		5
IK 09		10
IK 10		20

# ELECTROMAGNETIC EMISSIONS AND BUSBAR



## SECTION CONTENT

- 154 Measurement of Magnetic Induction
- 156 Magnetic Induction Graphs

## Measurement of magnetic induction

### General features

Since 1994, with a study carried out by Chalmers University of Technology of Goteborg, Legrand has taken an interest in the issues linked with the electromagnetic emissions in their own products, keeping at the front of the legislative directive of the latest years, which only recently have imposed quality standards that were already widely met by Legrand busbar trunking systems

The ACAE (Association for the Certification of Electric and Electronic Equipment) certified internal lab is capable of carrying out the measurement of the electromagnetic emissions of busbar trunking systems. This measurement is nowadays one of the type tests to which the products are subjected before they reach the market

The solution of the busbar trunking system in itself already minimises electromagnetic emissions, which are much lower when compared with those generated by cables with the same current intensity

It is a well-known fact that the electromagnetic field is the result of the superimposition of two fields: the electric and the magnetic field. The first one is totally shielded by the equipotential metal casing of the busbar trunking system, while the second is very low due to the intrinsic characteristic of the busbar trunking system. More precisely, due to the fact that the busbar conductors are extremely close inside the busbar package, the three busbar conductors, crossed by three balanced currents displaced by  $120^\circ$ , induce fields that tend to overlap, cancelling one another, therefore resulting in an extremely low external impact

However, also in conditions of imperfect current balance, the metal structure making up the casing of the busbar trunking system is capable of reducing most of the magnetic field, which otherwise would spread through the surrounding environment



The Legrand lab during the tests for the approval certification of SCP busbar trunking systems

## ■ Technical informations

The lab tests carried out on the products show how the magnetic induction emitted by SCP busbar trunking systems, measured at a distance of approximately one metre, is well below the critical value of 3  $\mu\text{T}$

With Legislative Decree DPCM dated 8/7/2003, Italian law set the first exposure limit at 100  $\mu\text{T}$

In addition, in locations where attendance is expected for no less than four hours a day, an attention value of 10  $\mu\text{T}$  has been set, to avoid possible long term effects on health. In the decree, the 3  $\mu\text{T}$  threshold is indicated as the "quality objective". However, as the product is intended for the European and world market, low magnetic emission is a fundamental point that cannot be disregarded, to ensure a presence in foreign countries: one example of this is Germany, where for over 10 years the regulation has set a cautionary limit of 3  $\mu\text{T}$  as the maximum permitted threshold in certain structures, like for example hospitals, so much so that in these types of environments the busbar trunking system has become a mandatory choice, as well as a high quality one

The high quality standard guaranteed by busbar trunking systems can be further appreciated by comparing the emission values measured against those of other commonly used equipment, as taken from table 7.1 of CEI 211-6 standard

The measurements obtained on aluminium SCP busbar trunking systems with ratings of 2500 A (carried out in compliance with the requirements of the technical product standard CEI EN 61439-6), show that the magnetic induction generated by the busbar is in the range of 1.5 - 2  $\mu\text{T}$  at a distance of one metre from the busbar itself

These values also apply near the electro-mechanic junction, which is considered the critical point due to the wider distance between the busbar conductors in this position

**Levels of exposure to industrial frequency magnetic field sources (table 7.1 from CEI 211-6 standard)**

Source	Magnetic induction ( $\mu\text{T}$ )	Distance
Electric shaver	150-240	on the face
Hairdryer	1-13	10-20 cm
Blender	0.9	40 cm
12 V, 20 W halogen lamp	0.5	30 cm
Aerosol therapy equipment	20-50	20-30 cm
Electric blanket	2	on contact
21 inch television set	0.3	50 cm
Washing machine	3.4	50 cm
Dishwasher	0.05	50 cm
Electric oven	0.4	20 cm
600 W drill	2	on the bust
100 W welding machine	14.5	on the bust
225 W grinder	0.8	40 cm
1.100 W compressor	8.2	40 cm
2.150 W arc welding machine	23.2	40 cm
75 MW, 55-65 kA, 150 t arc oven	100-270	in proximity
Electric scalpel	2.9	in proximity
Battery charger	22.9	in proximity
Echograph	0.8	operator position
Projector	2.3	20 cm

**B [ $\mu\text{T}$ ]**

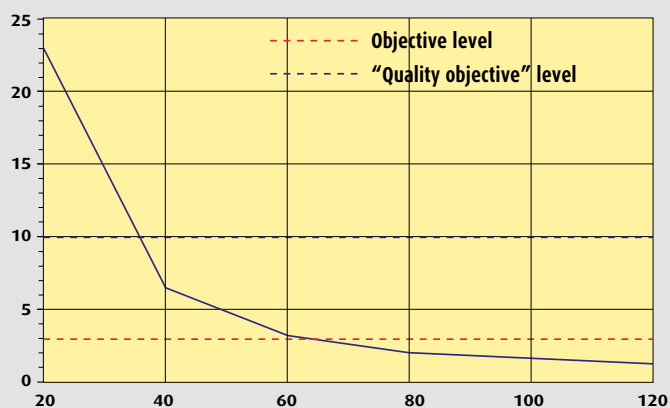

One-dimensional trend of the magnetic induction near the junction. The blue dash shows the "objective" level and the red dash shows the "quality objective" required by law

## Magnetic induction graphs

### ■ AT 60 cm from the busbar

The graphs shown refer to the measurements carried out on the Aluminium SCP prefabricated electric busbar with rated load of 2500 A, crossed by a 2500 A current

The measurements carried out at 60 cm from the junction are to be considered as made higher due to the magnetic induction generated by the busbar power supply: due to the intrinsic geometry of the measurement lab structure, it must be assumed that the measurement area is also affected by a magnetic induction of no less than 1.5  $\mu\text{T}$  generated by the line power supply

In view of this observation, in case of actual operating line the quality objective indicated by Legislative Decree DPCM dated 8/7/2003 is widely met at less than one metre from the axis of the busbar

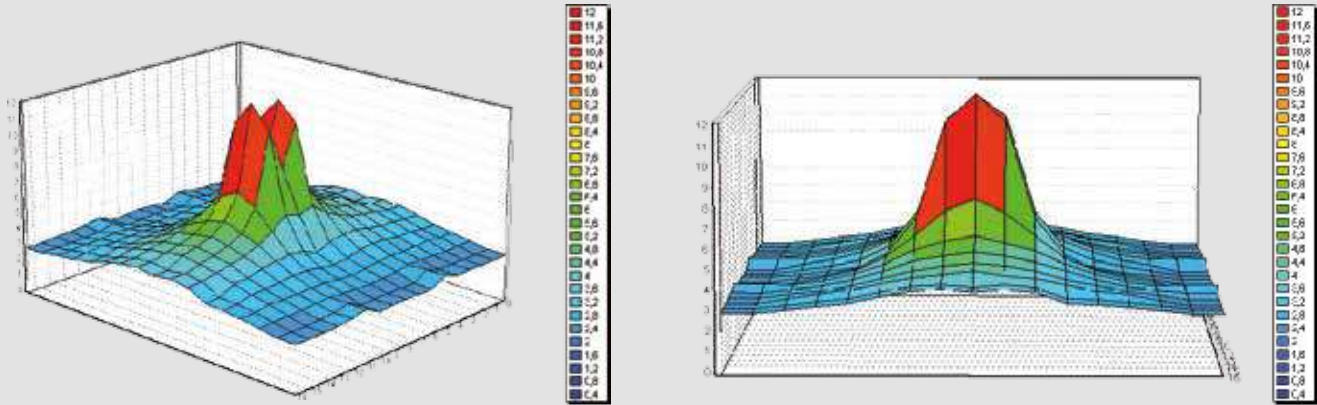

Three-dimensional development of magnetic induction around the busbar at 60 cm from the junction.

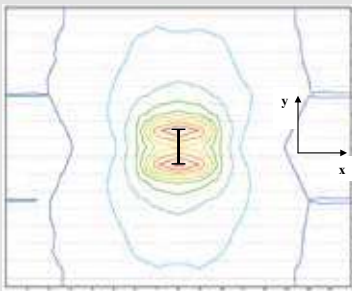

Two-dimensional map of the magnetic induction around the busbar at 60 cm from the junction. At the centre of the graphic is a schematic representation of the busbar

Note: the cells making up the measurement grid are 20 cm squares

As it can be seen on the graph, up to a distance of 40 cm approximately from the axis of the busbar, the field appears generated by two separate sources. This is due to the fact that the busbar being analysed consists of two series of busbar conductors set in parallel at a distance of approximately 5 cm from each other

### ■ NEAR THE JUNCTION

It is considered important to show, side by side with the results relating to straight elements, also the results of the measurement carried nearby the electro-mechanic junction of the busbar element. This location may in fact be considered critical, as here magnetic induction is higher due to the higher distance between the busbar conductors corresponding to the various phases of the line

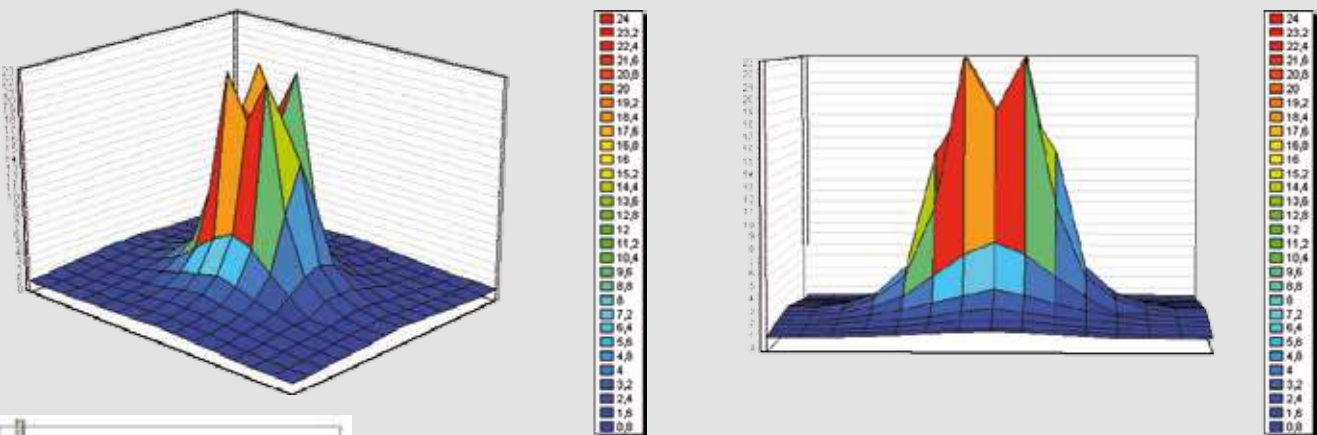

Three-dimensional development of magnetic induction near the joint

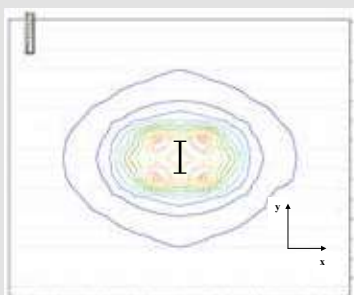

Two-dimensional map of magnetic induction near the junction. At the centre of the graphic is a schematic representation of the busbar

# INSTALLATION AND CHECKS



## SECTION CONTENT

- 158 Assembly Checks Before Operation
- 160 Regular Checks

## Assembly checks before operation

### General features

Once the line assembly has been completed, before starting operation of the system it is recommended that some checks are carried out, to ensure correct installation and integrity of the components. The checks must be carried out by competent and suitably trained personnel, following the requirements of CEI 11-27 and EN 50110-1:2004-11 (CEI 11-48) standards, or equivalent international standards or specifications from individual countries.

### Busbar checks

#### Junctions

Open a sample (10%) of the mechanical junctions

Check the following:

- 1) Correct assembly direction of the Monobloc and correspondence of mechanical positioning marks (pins and lines). In case of wrong positioning, remove the Monobloc and reassemble correctly after checking its integrity. Otherwise, fully replace the Monobloc.
- 2) Integrity of the insulating parts, paying particular attention to breaks and chipping. Check for any dust or dirt. In case of damaged insulating parts, replace the whole Monobloc. In case of dust and dirt, clean as necessary.
- 3) Ensure that the Monobloc is correctly centred in relation to the element busbar conductors. In case of wrong positioning, realign as necessary, after checking the Monobloc for integrity.
- 4) Check the torque of the self-shearing bolts (80-90 Nm) using a calibrated torque wrench. This check must be carried out with the line at ambient temperature. If the torque is lower than required (below the required value), adjust as necessary.

#### Connection to the control panel

On the control panel connection carry out the following checks:

- 1) The distance between busbar conductors with different power must exceed 40 mm. In case of shorter distance, contact the Legrand System Development Office for assessing the possible use of suitable insulating material.
- 2) Check the connection screws for correct torque values (value required 85 Nm for M12, 100 Nm for M14, 120 Nm for M16, 170 Nm for M18, 25 Nm for M8 and 50 Nm for M10). The above checks must be carried out by qualified personnel with suitable technical training, and having control duties/responsibilities during the installation activities.

### Electric safety tests

Carry out all the tests required by the applicable technical installation regulations, such as tests on the insulation between the phases and towards the earth at 1000 V, with minimum value of 100 MOhm for each line section. If the insulation value is lower than 100 MOhm, it will be necessary to carry out a full system check, starting from the integrity of the insulating parts of the individual Monoblocs. If insulation is still insufficient, split the system in two sections and check each section individually to identify the element with low insulation. Continue splitting the system into further sections if insulation remains insufficient.

### Thermal checks

The measurement of temperatures may be carried out using contact thermal sensors, optical pyrometers, or thermo-chambers. After leaving the system in operation at maximum operating current for at least six hours, carry out a thermal measurement. Affix labels on the hot points and mark them with progressive numbers to identify the different elements. Repeat the thermal measurements on the labels.

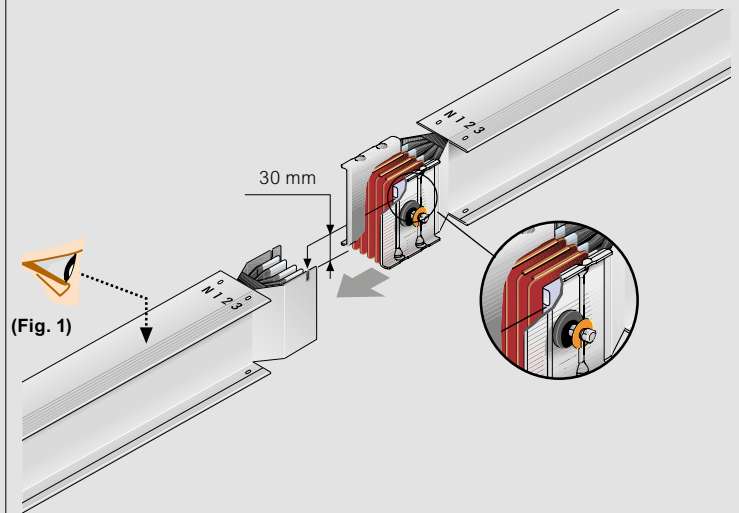

## ■ Checks on plug-in boxes

Tests to be carry out with the system voltage disconnected and after connecting to the earth the phases downstream the plug-in box, in order to discharge any static charges that may be present downstream the circuit (with an insulated device)

### Bolt-on box type

Carry out the same checks required for junctions  
Check the torque of the screws connecting the electro-mechanic junctions and the busbar conductors.  
If necessary, tighten the connection screws again

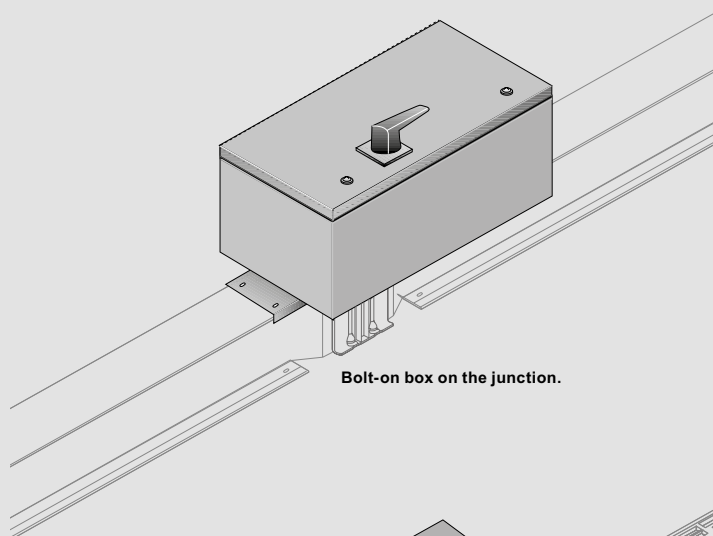

Bolt-on box on the junction.

### Plug-in box type

Check the contact resistance between the clamp upstream the protection device and the corresponding busbar conductor on the previous window  
In case of resistance over 100  $\mu\text{Ohm}$ , the box may have been fitted incorrectly  
Remove the box, check the status of the clamp block and the outlet on the element  
If the outlet is broken and the contacts have moved back inside the clamp block, it will be necessary to check insulation between the phases of the system, replace the box, and identify the distribution outlet as non-usable. Fit the new box on a different outlet  
Do not use the damaged one

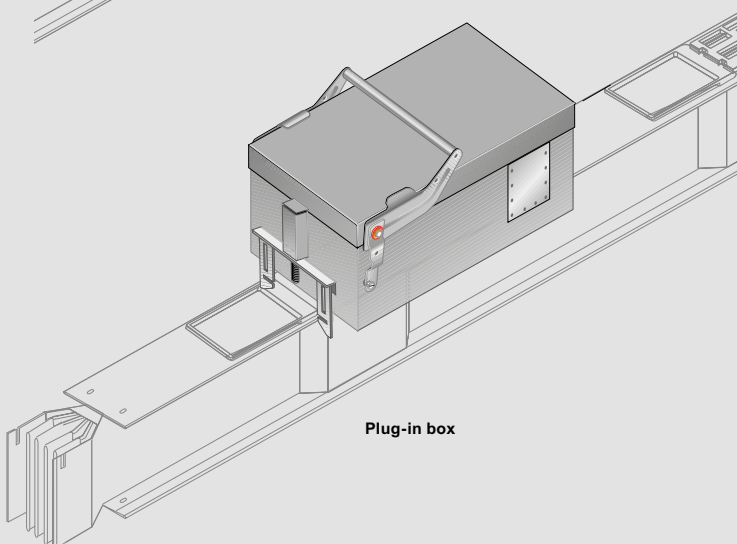

Plug-in box

### Thermal checks

Carry out a thermal check on the cover near the lock.  
This can be carried out using contact thermal sensors, optical pyrometers or thermo-chambers  
The measurement must be carried out on boxes that have been in operation for at least six hours at regime conditions  
Indicate the values on the attached form together with the ambient temperature and the operating current



## Regular checks

These are regular checks to be carried out after the first year the line has been in operation. Subsequently, the same checks should be carried out every two years.

### ■ Busbar checks

#### Thermal checks

With the system operating at maximum operating current for at least six hours, carry out a thermal measurement, particularly on the points of the labels applied during installation.

If the relative overtemperature detected (DT) exceeds 55 K, or deviates of more than 15 K from the temperature measured during the checks carried out when the line was installed, contact Legrand Technical support. The measurement of temperatures may be carried out using contact thermal sensors, optical pyrometers, or thermo-chambers.

#### Junctions

Open a sample (10%) of the electro-mechanic junctions.

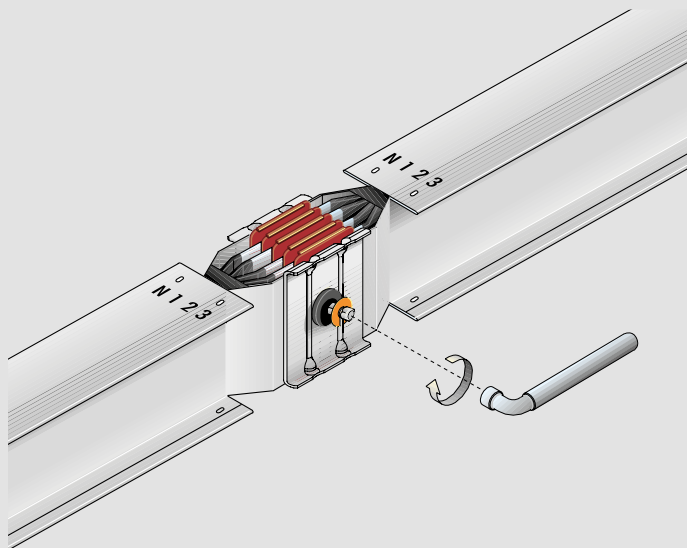

On each electromechanical junction check the following:

- 1) Integrity of the insulating material, with particular attention to any breaks and colour alteration. If any are present, fully replace the monobloc.
- 2) Ensure that the protection flanges of mechanical junctions are free from any traces of water, lime scale, or foreign material (dust, dirt, etc.). If this is the case, also check the condition of the busbars near the Monobloc. Dry any wet parts using hot air at a temperature not exceeding 80 °C, and remove any residual with bland reactants (e.g. trichloroethylene) that will not attack or cause abrasions to the surface treatment (galvanic, tin), or the contact surface (Copper).

- 3) Correct adhesion of the Monobloc to the busbar conductors (if necessary using a 0.05 mm feeler), and full contact of conductor parts.
- 4) Check the torque of the self-shearing bolts using torque wrench calibrated at 85 Nm. This check must be carried out with the line at ambient temperature. In case of values lower than the required ones adjust as necessary (85 Nm).

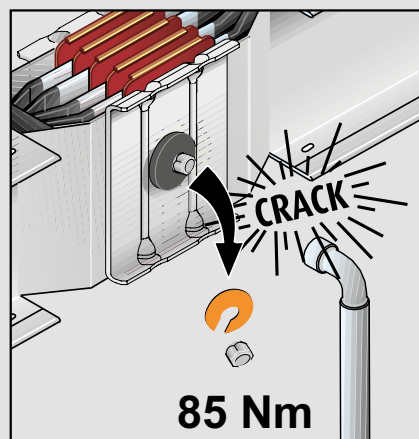

- 5) Insulation tests at 1000 V, with minimum value 100 MOhm, for each insulated section of the line. The insulation test must be carried out between phase and phase, phase and neutral, and phase and casing for each single phase. If this test is unsuccessful, identify the faulty line section and replace or carry out further checks as necessary.

In case of negative results, extend the checks to all junctions and contact Legrand Technical support.

### ■ Checks on plug-in boxes

It is recommended that these checks are carried out every year. Carry out a thermal check on the cover near the lock. This can be carried out using contact thermal sensors, optical pyrometers or thermo-chambers. The measurement must be carried out on boxes that have been in operation for at least six hours at regime conditions. Indicate the values on the attached form together with the ambient temperature and the operating current. If the relative temperature detected (DT) exceeds 55 K or deviates of more than 15 K from the temperature measured during the checks carried out when the line was installed, contact Legrand Technical support. Check the connection screws for correct torque.



## Design example

### Technical informations

Thanks to the flexibility of the SCP line, the possibility of customising the system according to one's own requirements. It is therefore possible to request special products such as continuous current or particular frequency (60Hz) distribution systems, or, as it is the case for the food sector, with stainless steel casing

Possible special requirements:

- 200% neutral
- 5 conductor version with separate FE earth
- 3 conductor version
- painting in customised colour
- fitting with Al/Cu earth conductors
- F class insulation
- arrangement for continuous current systems
- stainless steel casing
- Aluminium casing

Below is the example of a system path

The figures below show the initial situation, listing all the measurements that must be known

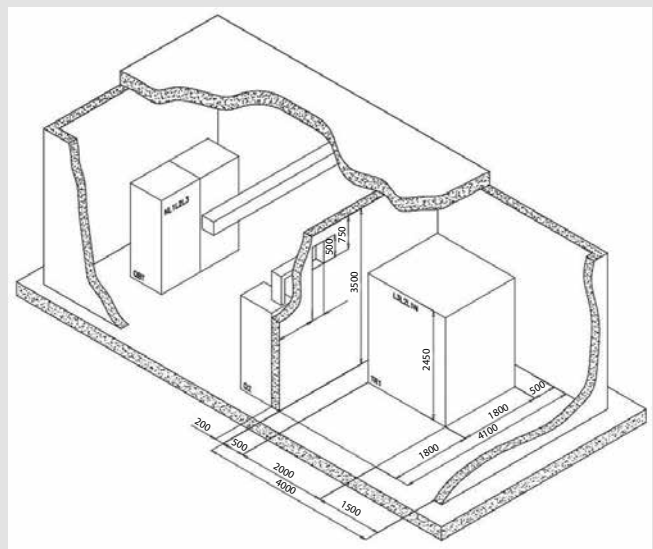
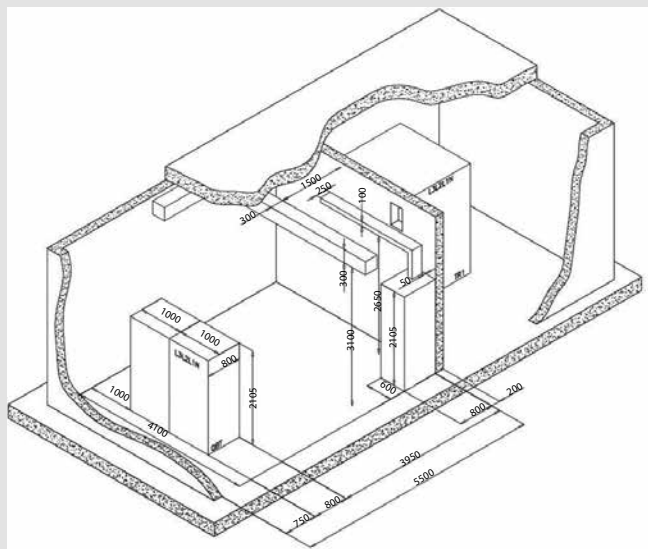
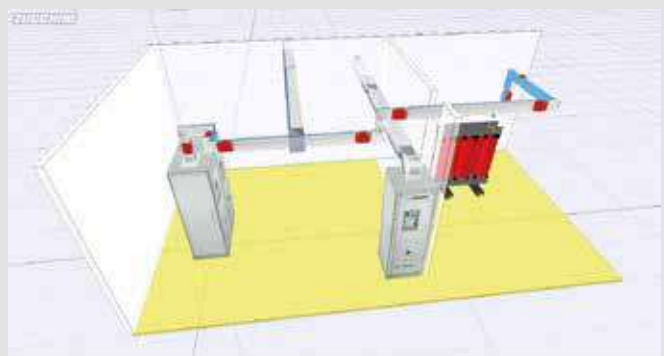
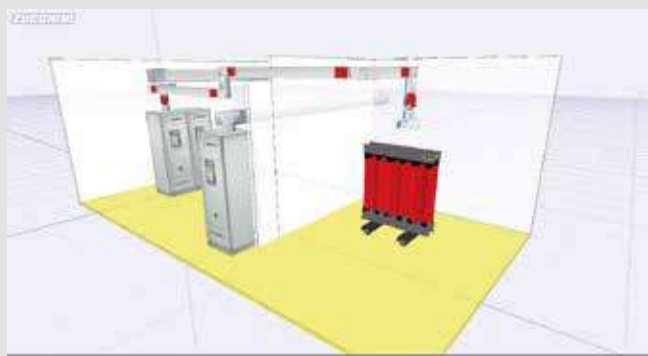

### Path not completely defined

If the path cannot be defined with sufficient degree of precision, some parts may be left out and ordered at a later stage

In order to simplify the process of taking the necessary measurements for the definition of the completion items, it is recommended that the supply of all sections with direction changes is defined from the start, leaving the completion of straight section to a later stage

To obtain the correct measures of the elements to be ordered see page 139

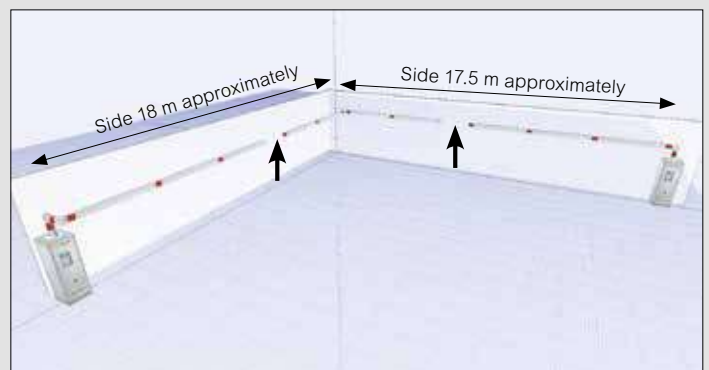

**NOTE:** The yellow arrows indicate the elements that can be dealt with at a later stage, and the correct layout of those supplied initially

# Data Center

real example of Legrand busbar applied in a Data Center

## Example of application



Year of installation: **2013**  
 Building with **3 floors**

## Material used for supply electrical power energy:

Number of total busbar lines: **54**

- **6 lines ( SCP 3200A AI – 3P+N – IP55 )**  
 Dedicated to supply electrical energy  
**54** used SCP PLUG-IN BOX 630A SWITCH DPX

- **48 lines ( MR 400A AI – 3P+N – IP40 )**  
**16 lines for floor**  
 Dedicated to distribute the electrical energy  
 at different rack present in data center  
**1194** used MRF PLUG-IN BOX 63A EMPTY



**MR 400 A AI**  
 3P + N - IP40

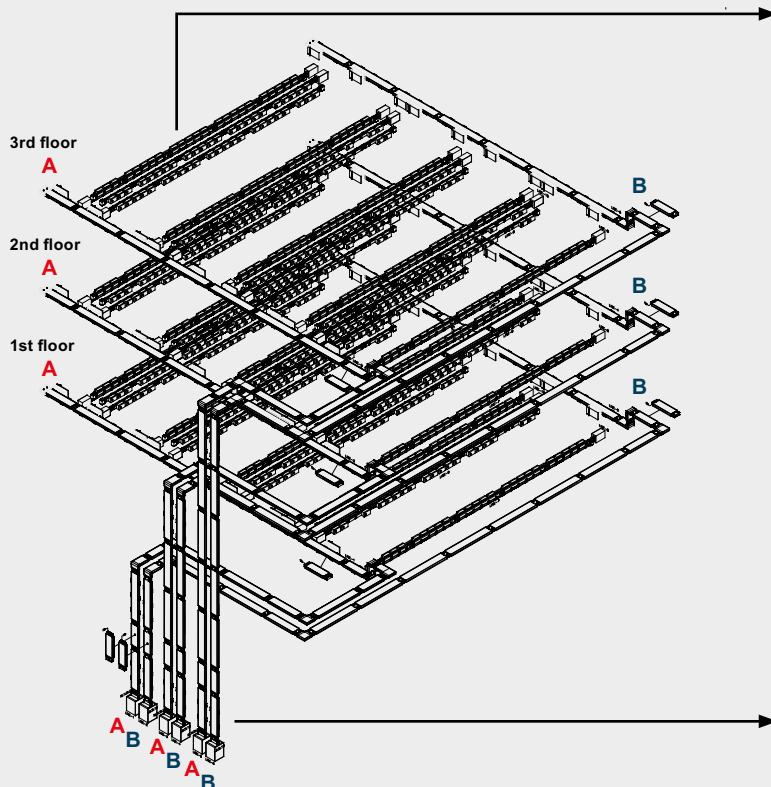

**SCP 3200A AI**  
 3P+N – IP55



**A B A B**

**A: power supply line**  
**B: emergency line**



# NOTES

---

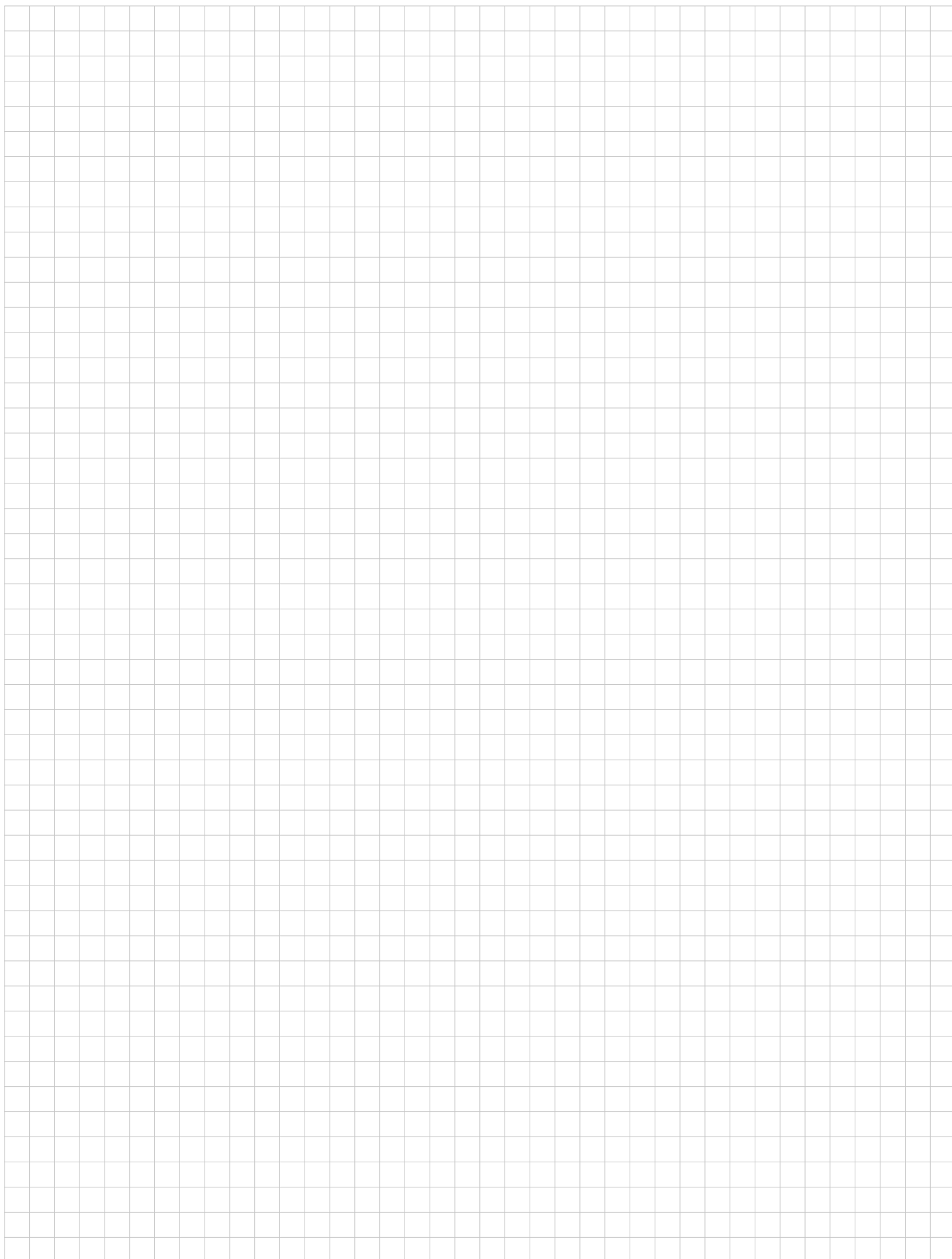



World Headquarters and  
International Department  
87045 Limoges Cedex - France  
Tel : + 33 (0) 5 55 06 87 87  
Fax : + 33 (0) 5 55 06 74 55

EX215028 - 05/2016

In accordance with its policy  
of continuous improvement, the  
Company reserves the right to change  
specifications and designs without  
notice. All illustrations, descriptions,  
dimensions and weights in this  
catalogue are for guidance and cannot  
be held binding on the Company.